



BANSAL ROOFING PRODUCTS LIMITED

Corporate Identity Number: - U25206GJ2008PLC053761

Our Company was originally incorporated on May 01, 2008, as "Bansal Roofing Private Limited" under the provisions of the Companies Act, 1956 with the Registrar of Companies, Gujarat, Dadra & Nagar Haveli. Pursuant to Shareholders Resolution passed at the Extra Ordinary General Meeting of the Company held on August 24, 2013 name of our Company was changed to "Bansal Roofing Products Private Limited" from "Bansal Roofing Private Limited" and a fresh Certificate of Incorporation dated August 29, 2013 was issued by the Registrar of Companies, Gujarat, Dadra & Nagar Haveli. Subsequently, our Company was converted into a public limited company pursuant to Shareholders Resolution passed at the Extra Ordinary General Meeting of the Company held on November 1, 2013 and the name of our Company was changed to "Bansal Roofing Products Limited" pursuant to issuance of fresh Certificate of Incorporation dated November 19, 2013 issued by the Registrar of Companies, Gujarat, Dadra & Nagar Haveli. For details of the changes in our Name and Registered Office, please see section titled "History and Certain Corporate Matters" on page 90 of this Prospectus.

Registered Office: 3/2, Labdhi Industrial Estate, Acid Mill Compound, Ranmukteshwar Road, Pratapnagar, Vadodara – 390004, Gujarat, India
Tel. No. +91-265-2580178, **Fax No.** +91-265-2581365 **E-mail:** cs@bansalroofing.com **Website:** http://www.bansalroofing.com

Contact Person: Ms. Harneetkaur S. Anand (Company Secretary & Compliance Officer)

PROMOTERS OF OUR COMPANY: MR. KAUSHALKUMAR S. GUPTA & MRS. SANGEETA K. GUPTA

THE ISSUE

PUBLIC ISSUE OF 6,80,000 EQUITY SHARES OF FACE VALUE OF ₹ 10.00 EACH OF BANSAL ROOFING PRODUCTS LIMITED ("OUR COMPANY" OR "THE ISSUER") FOR CASH AT A PRICE OF ₹ 30.00 PER EQUITY SHARE (INCLUDING A SHARE PREMIUM OF ₹ 20.00 PER EQUITY SHARE) ("ISSUE PRICE") AGGREGATING TO ₹ 204.00 LAKHS ("THE ISSUE"), OF WHICH 36,000 EQUITY SHARES OF FACE VALUE OF ₹ 10.00 EACH, AGGREGATING TO ₹ 10.80 LAKHS WILL BE RESERVED FOR SUBSCRIPTION BY MARKET MAKER ("MARKET MAKER RESERVATION PORTION"). THE ISSUE LESS THE MARKET MAKER RESERVATION PORTION I.E. ISSUE OF 6,44,000 EQUITY SHARES OF FACE VALUE OF ₹ 10.00 EACH AT AN ISSUE PRICE OF ₹ 30.00 PER EQUITY SHARE AGGREGATING TO ₹ 193.20 LAKHS (IS HEREINAFTER REFERRED TO AS THE "NET ISSUE"). THE ISSUE AND THE NET ISSUE WILL CONSTITUTE 30.95% AND 29.31%, RESPECTIVELY OF THE POST ISSUE PAID UP EQUITY SHARE CAPITAL OF OUR COMPANY. FOR FURTHER DETAILS, PLEASE REFER TO SECTION TITLED "TERMS OF THE ISSUE" BEGINNING ON PAGE 174 OF THIS PROSPECTUS.

THE FACE VALUE OF THE EQUITY SHARES IS ₹ 10.00 EACH AND THE ISSUE PRICE IS ₹ 30.00. THE ISSUE PRICE IS 3 TIMES OF THE FACE VALUE

THIS ISSUE IS BEING MADE IN TERMS OF CHAPTER XB OF THE SEBI (ICDR) REGULATIONS, 2009, AS AMENDED. THIS ISSUE IS A FIXED PRICE ISSUE AND ALLOCATION IN THE NET ISSUE TO THE PUBLIC WILL BE MADE IN TERMS OF REGULATION 43(4) OF THE SEBI (ICDR) REGULATIONS, 2009, AS AMENDED. FOR FURTHER DETAILS, PLEASE REFER TO SECTION TITLED "ISSUE PROCEDURE" BEGINNING ON PAGE 180 OF THIS PROSPECTUS.

Retail Individual Investors may participate in the Issue through an Application Supported by Blocked Amount ("ASBA") process providing details about the bank account which will be blocked by the Self Certified Syndicate Banks ("SCSBs"). However, investors other than Retail Individual Investors shall compulsorily participate through the ASBA process only providing details about the bank account which will be blocked by the SCSBs. In case of delay, in refund if any, our Company shall pay interest on the application money at the rate of 15% per annum for the period of delay. For further details, please refer to section titled "Issue Procedure" beginning on page 180 of this Prospectus.

ELIGIBLE INVESTORS

For details in relation to Eligible Investors, please refer to section titled "Issue Procedure" beginning on page 180 of this Prospectus.

RISK IN RELATION TO THE FIRST ISSUE

This being the first public issue of the Equity Shares of our Company, there has been no formal market for the Equity Shares of our Company. The face value of the Equity Shares of the Company is ₹ 10.00 per equity share and the Issue Price is 3 times of the face value. The Issue Price (has been determined and justified by our Company in consultation with the Lead Manager as stated under the paragraph 'Basis for Issue Price' on page 55 of this Prospectus) should not be taken to be indicative of the market price of the Equity Shares after the Equity Shares are listed. No assurance can be given regarding an active and/or sustained trading in the Equity Shares of our Company or regarding the price at which the Equity Shares will be traded after listing.

GENERAL RISKS

Investments in equity and equity related securities involve a degree of risk and investors should not invest any funds in this Issue unless they can afford to take the risk of losing their investment. Investors are advised to read the "Risk Factors" carefully before taking an investment decision in this Issue. For taking an investment decision, investors must rely on their own examination of our Company and the Issue including the risks involved. The Equity Shares offered in the Issue have not been recommended or approved by the Securities and Exchange Board of India ("SEBI"), nor does SEBI guarantee the accuracy or adequacy of this Prospectus. **Specific attention of the investors is invited to the section titled 'Risk Factors' beginning on page 11 of this Prospectus.**

ISSUER'S ABSOLUTE RESPONSIBILITY

Our Company having made all reasonable inquiries, accepts responsibility for and confirms that this Prospectus contains all information with regard to our Company and this Issue, which is material in the context of this Issue, that the information contained in this Prospectus is true and correct in all material aspects and is not misleading in any material respect, that the opinions and intentions expressed herein are honestly held and that there are no other facts, the omission of which makes this Prospectus as a whole or any of such information or the expression of any such opinions or intentions misleading in any material respect.

LISTING

The Equity Shares offered through this Prospectus are proposed to be listed on the SME Platform of BSE Limited ("BSE"). In terms of the Chapter XB of the SEBI (ICDR) Regulations, 2009, as amended, we are not required to obtain an in-principle listing approval for the shares being offered in this issue. However, our Company has received an in-principle approval letter dated June 6, 2014 from BSE for using its name in this offer document for listing of our shares on the SME Platform of BSE. For the purpose of this Issue, the Designated Stock Exchange will be the BSE Limited.

LEAD MANAGER TO THE ISSUE

REGISTRAR TO THE ISSUE



HEM SECURITIES LIMITED
 14/15, Khatau Building, 1st Floor, 40, Bank Street, Fort, Mumbai - 400 001
Tel. No.: +91-22 – 2267 1543 / 44,
Fax No.: +91-22 – 2262 5991
Website: www.hemonline.com
Email: ib@hemonline.com
Investor Grievance Email: redressal@hemonline.com
Contact Person: Mr. Mohit Baser
SEBI Regn. No. INM000010981



SHAREX DYNAMIC (INDIA) PRIVATE LIMITED
 Unit-1, Luthra Industrial Premises, 1st Floor, 44 - E, M Vasanti Marg, Andheri - Kurla Road, Safed Pool, Andheri (East), Mumbai – 400 072
Tel. No.: +91-22 – 2851 5606 / 44,
Fax No.: +91-22 – 2851 2885
Website: www.sharexindia.com
Email: info@sharexindia.com
Contact Person: Mr. K. C. Ajitkumar
SEBI Regn. No. INR000002102

ISSUE PROGRAMME

ISSUE OPENS ON: THURSDAY, JUNE 26, 2014

ISSUE CLOSES ON: MONDAY, JUNE 30, 2014

TABLE OF CONTENTS

SECTION	CONTENTS	PAGE NO.
I	GENERAL	
	DEFINITIONS AND ABBREVIATIONS	1
	CERTAIN CONVENTIONS, USE OF FINANCIAL INFORMATION & MARKET DATA AND CURRENCY OF FINANCIAL PRESENTATION	8
	FORWARD LOOKING STATEMENTS	10
II	RISK FACTORS	11
III	INTRODUCTION	
	SUMMARY OF OUR INDUSTRY	25
	SUMMARY OF OUR BUSINESS	27
	SUMMARY OF OUR FINANCIALS	29
	THE ISSUE	33
	GENERAL INFORMATION	34
	CAPITAL STRUCTURE	39
	OBJECTS OF THE ISSUE	49
	BASIC TERMS OF ISSUE	54
	BASIS FOR ISSUE PRICE	55
	STATEMENT OF TAX BENEFITS	57
IV	ABOUT THE ISSUER COMPANY	
	INDUSTRY OVERVIEW	66
	OUR BUSINESS	72
	KEY INDUSTRY REGULATIONS AND POLICIES	82
	HISTORY AND CERTAIN CORPORATE MATTERS	90
	OUR MANAGEMENT	93
	OUR PROMOTERS	105
	OUR PROMOTER GROUP AND PROMOTER GROUP ENTITIES	108
	DIVIDEND POLICY	112
V	FINANCIAL INFORMATION OF THE COMPANY	
	FINANCIAL STATEMENTS OF THE COMPANY	113
	STATEMENT OF FINANCIAL INDEBTEDNESS	140
	MANAGEMENT'S DISCUSSION AND ANALYSIS OF FINANCIAL CONDITIONS AND RESULTS OF OPERATIONS	142
VI	LEGAL AND OTHER INFORMATION	
	OUTSTANDING LITIGATIONS AND MATERIAL DEVELOPMENTS	151
	GOVERNMENT AND OTHER APPROVALS	157
	OTHER REGULATORY AND STATUTORY DISCLOSURES	161
VII	ISSUE RELATED INFORMATION	
	TERMS OF THE ISSUE	174
	ISSUE STRUCTURE	178
	ISSUE PROCEDURE	180
	RESTRICTIONS ON FOREIGN OWNERSHIP OF INDIAN SECURITIES	199
VIII	MAIN PROVISIONS OF THE ARTICLES OF ASSOCIATION	201
IX	OTHER INFORMATION	
	MATERIAL CONTRACTS AND DOCUMENTS FOR INSPECTION	239
	DECLARATION	240

**THIS PAGE
HAS BEEN
LEFT BLANK
INTENTIONALLY.**

SECTION I: GENERAL

DEFINITIONS AND ABBREVIATIONS

Unless the context otherwise indicates/implies, the terms and abbreviations stated hereunder shall have the meanings as assigned therewith. References to statutes, rules, regulations, guidelines and policies will be deemed to include all amendments and modifications notified thereto.

Conventional / General Terms

Term	Description
"Bansal Roofing Products Limited", "BRPL", "Bansal", "We" or "us" or "our Company" or "the Issuer" or "the Company"	Unless the context otherwise requires, refers to Bansal Roofing Products Limited, a Company incorporated under the Companies Act, 1956 vide a Certificate of Incorporation issued by the Registrar of Companies, Gujarat, Dadra and Nagar Havelli.
"you", "your" or "yours"	Prospective investors in this Issue
AOA / Articles / Articles of Association	Articles of Association of Bansal Roofing Products Limited, as amended from time to time
Audit Committee	A Committee constituted in accordance Clause 52 of the SME Listing Agreement (BSE) in the meeting of our Board of Directors held on January 23, 2014.
Bankers/Lenders to our Company	State Bank of India, 1 st Floor, Prime Complex, Opposite Shreyash School, Manjalpur, Vadodara, – 390011, Gujarat, India
Board of Directors/ the Board / our Board	The Board of Directors of our Company or a duly constituted committee thereof.
Companies Act / Act	The Companies Act, 1956 as amended and The Companies Act, 2013 to the extent of such of the provisions as have come into effect vide Ministry of Corporate Affairs' Notifications till date.
Depositories Act	The Depositories Act, 1996, as amended
Depositories	National Securities Depository Limited (NSDL) and Central Depository Services (India) Limited (CDSL)
Director(s)	The director(s) of our Company.
Equity Shares	Equity Shares of our Company of Face Value of ₹10.00 each unless otherwise specified in the context thereof
Group Companies	Group companies shall mean companies, firms, ventures promoted by the Promoters of our Company irrespective of whether such entities are covered under Companies Act, or not and as disclosed in the section titled " <i>Our Promoter Group and Promoter Group Entities</i> " beginning on page 108 of this Prospectus.
MOA / Memorandum / Memorandum of Association	Memorandum of Association of our Company, as amended till date
NRI/ Non-Resident Indian/Non Resident	A person resident outside India, as defined under FEMA and who is a citizen of India or a person of Indian origin, each such term as defined under the FEMA (Deposit) Regulations, 2000, as amended.
Peer Review Auditor	Independent Auditor having a valid Peer Review certificate in our case being M/s. V. J. Amin & Co., Chartered Accountants
Person or Persons	Any individual, sole proprietorship, unincorporated association, unincorporated organization, body corporate, corporation, Company, partnership, limited liability Company, joint venture, or trust or any other entity or organization validly constituted and/or incorporated in the jurisdiction in which it exists and operates, as the context requires
Promoter/Promoters	Shall mean promoters of our Company i.e. Mr. Kaushalkumar S. Gupta and Mrs. Sangeeta Gupta
Promoter Group Companies	Persons and entities covered under Regulation 2(1)(zb) of the SEBI (ICDR) Regulations as enlisted in the section titled " <i>Our Promoter Group and Promoter Group Entities</i> " beginning on page 108 of this Prospectus.
Registered Office of our Company	3/2, Labdhi Industrial Estate, Acid Mill Compound, Ranmukteshwar Road, Pratapnagar, Vadodara – 390004, Gujarat, India
RoC / Registrar of Companies	Registrar of Companies, Gujarat, Dadra and Nagar Havelli, Roc Bhavan, Opposite Rupal Park Society, Behind Ankur Bus Stop, Naranpura, Ahmedabad – 380013, India

Bansal Roofing Products Limited

Term	Description
SEBI	Securities and Exchange Board of India constituted under the SEBI Act, 1992
SEBI Act	Securities and Exchange Board of India Act, 1992, as amended
SEBI (ICDR) Regulations, 2009	SEBI (Issue of Capital and Disclosure Requirements) Regulations, 2009, as amended.
SEBI Takeover Regulations	Securities and Exchange Board of India (Substantial Acquisition of Shares and Takeover) Regulations, 2011.
SEBI Insider Trading Regulations	The SEBI (Prohibition of Insider Trading) Regulations, 1992, as amended, including instructions and clarifications issued by SEBI from time to time.
Sub-Account	Sub-accounts registered with SEBI under the SEBI (Foreign Institutional Investor) Regulations, 1995, other than sub-accounts which are foreign corporates or foreign individuals.
Statutory Auditors/ Auditor	The statutory auditor of our Company being M/s. Santlal Patel & Co., Chartered Accountants

Issue Related Terms

Term	Description
Allot/ Allotment/ Allotted	Unless the context otherwise requires, issue/allotment of Equity Shares pursuant to the Issue to successful Applicants.
Allottee	An applicant to whom the Equity Shares are being / have been issued /allotted.
Allotment Advice	Note or advice or intimation of Allotment sent to the Bidders/Applicants who have been allotted Equity Shares after the Basis of Allotment has been approved by the designated Stock Exchanges
Applicant	Any prospective investor (including an ASBA Applicant) who makes an application pursuant to the terms of the Prospectus and the Application Form.
Application Amount	The number of Equity Shares applied for and as indicated in the Application Form multiplied by the price per Equity Share payable by the Applicants on submission of the Application Form.
Application Form	The form in terms of which the Applicant shall make an application to subscribe to the Equity Shares of our Company.
Application Supported by Blocked Amount / ASBA	An application, whether physical or electronic, used by all Applicants to make application authorizing a SCSB to block the application amount in the ASBA Account maintained with such SCSB.
ASBA Account	Account maintained by an ASBA Bidder with a SCSB which will be blocked by such SCSB to the extent of the Application Amount of the ASBA Applicant.
ASBA Applicant	Prospective investor who apply through ASBA. Pursuant to SEBI circular no. CIR/CFD/DIL/1/2011 dated April 29, 2011, Non- Retail Investors i.e. QIBs and Non-Institutional Investors participating in this Issue are required to mandatorily use the ASBA facility to submit their Applications.
ASBA Application Form	The form, whether physical or electronic, used by an ASBA Applicant to make an application, which will be considered as the application for Allotment for purposes of the Prospectus.
Basis of Allotment	The basis on which the Equity Shares will be allotted as described in the section titled " Issue Procedure-Basis of Allotment " beginning on page 193 of this Prospectus.
Bankers to the Company	Such banks which are disclosed as bankers to our Company in the chapter titled " General Information " on page 34 of this Prospectus
Broker Centres	Broker centres notified by the Stock Exchanges, where the Applicants can submit the Application Forms to a Registered Broker. The details of such broker centres, along with the names and contact details of the Registered Brokers, are available on the website of the BSE on the following link:- http://www.bseindia.com/Markets/PublicIssues/brokercentres_new.aspx?expandable=3
Business Day	Monday to Friday (except public holidays)
CAN or Confirmation of Allocation Note	The note or advice or intimation sent to each successful Applicant indicating the Equity Shares which will be Allotted, after approval of Basis of Allotment by the Designated Stock Exchange.
Client ID	Client Identification Number maintained with one of the Depositories in relation to demat account
Company Secretary and Compliance Officer	Ms. Harneetkaur S. Anand

Bansal Roofing Products Limited

Term	Description
Controlling Branches of SCSBs	Such branches of the SCSBs which co-ordinate Applications under this Issue made by the Applicants with the Lead Manager, the Registrar to the Issue and the Stock Exchanges, a list of which is provided on http://www.sebi.gov.in
Demographic Details	The demographic details of the Applicants such as their Address, PAN, Occupation and Bank Account details.
Depository / Depositories	A depository registered with SEBI under the SEBI (Depositories and Participant) Regulations, 1996
Depository Participant/DP	A depository participant as defined under the Depositories Act.
Designated Branches	Such branches of the SCSBs which shall collect the ASBA Application Form from the ASBA Applicant and a list of which is available on http://www.sebi.gov.in
Designated Date	The date on which the Escrow Collection Banks and the SCSBs transfer the funds from the Escrow Accounts and the ASBA Accounts, respectively, to the Public Issue Account, or the Refund Account, as appropriate, in terms of the Prospectus.
Draft Prospectus	Draft Prospectus dated May 26, 2014 issued in accordance with Section 32 of the Companies Act, 2013.
Eligible NRI	NRIs from such jurisdiction outside India where it is not unlawful to make an offer or invitation under the Issue and in relation to whom the Prospectus constitutes an invitation to subscribe for the Equity Shares on the basis of the terms thereof.
Eligible QFI	QFIs from such jurisdictions outside India (i) which are compliant with FATF standards and are signatories to the International Organisation of Securities Commissions (IOSCOs) Multilateral Memorandum of Understanding; (ii) who have opened demat accounts with SEBI registered qualified depository participants and (iii) where it is not unlawful to make an offer or invitation under the Issue and in relation to whom the Prospectus constitutes an invitation to subscribe to the Equity Shares offered thereby.
Escrow Account(s)	Account(s) opened with Escrow Collection Bank(s) for the Issue and in whose favour the Applicant (excluding the ASBA Applicants) will issue cheques or drafts in respect of the Application Amount when submitting an Application.
Escrow Agreement	Agreement entered into on June 4, 2014 amongst our Company, Lead Manager, the Registrar, the Escrow Collection Bank(s) for collection of the Application Amounts and for remitting refunds (if any) of the amounts collected to the Applicants (excluding the ASBA Applicants) on the terms and condition thereof.
Escrow Collection Bank(s)/Bankers to the Issue	The bank(s), which are clearing members and are registered with SEBI as Banker (s) to the Issue at which the Escrow Account for the Issue will be opened, in this case being HDFC Bank Limited.
FII / Foreign Institutional Investors	Foreign Institutional Investor (as defined under SEBI (Foreign Institutional Investors) Regulations, 1995, as amended) registered with SEBI under applicable laws in India.
First/Sole Applicant	The Applicant whose name appears first in the Application Form or Revision Form.
Issue Agreement	The agreement entered into on April 5, 2014 between our Company and Lead Manager pursuant to which certain arrangements are agreed in relation to the Issue.
Issue/Offer	Public Issue of 6,80,000 equity shares of face value ₹10.00 each of Bansal Roofing Products Limited for cash at a price of ₹ 30.00 per Equity Share (the " Issue Price "), including a share premium of ₹ 20.00 per equity share aggregating up to ₹ 204.00 Lakhs.
Issue Closing Date	The date after which the Lead Manager, Syndicate Member, Designated Branches of SCSBs and Registered Brokers will not accept any Application for this Issue, which shall be notified in a English national newspaper, Hindi national newspaper and a Gujarati regional newspaper each with wide circulation as required under the SEBI (ICDR) Regulations. In this case being Monday, June 30, 2014.
Issue Opening Date	The date on which the Lead Manager, Syndicate Member, Designated Branches of SCSBs and Registered Brokers shall start accepting Application for this Issue, which shall be the date notified in an English national newspaper, Hindi national newspaper and a Gujarati regional newspaper each with wide circulation as required under the SEBI (ICDR) Regulations. In this case being Thursday, June 26, 2014.
Issue Period	The period between the Issue Opening Date and the Issue Closing Date inclusive of both days and during which prospective Applicants can submit their Applications.
Issue Price	The price at which Equity Shares will be issued and allotted by our Company being ₹ 30.00 per Equity Share.
Issue Proceeds	Proceeds to be raised by our Company through this Issue, for further details please refer chapter title " Objects of the Issue " page no. 49

Bansal Roofing Products Limited

Term	Description
Listing Agreement	Unless the context specifies otherwise, this means the Equity Listing Agreement to be signed between our Company and the SME Platform of BSE Limited
LM / Lead Manager	The Lead Manager for the Issue being Hem Securities Limited.
Market Maker	Member Brokers of BSE who are specifically registered as Market Makers with the BSE SME Platform. In our case, Hem Securities Limited (Registration No. SMEMM0024801022013) is the sole Market Maker to the Issue.
Mutual Fund(s)	Mutual fund(s) registered with SEBI pursuant to the SEBI (Mutual Funds) Regulations, 1996, as amended.
Net Issue	The Issue (excluding the Market Maker Reservation Portion) of 6,44,000 equity shares of face value ₹ 10.00 each of Bansal Roofing Products Limited for cash at a price of ₹ 30.00 per Equity Share (the " <i>Issue Price</i> "), including a share premium of ₹ 20.00 per equity share aggregating up to ₹ 193.20 Lakhs.
Non Institutional Investors or NIIs	All Applicants, including sub accounts of FIIs registered with SEBI which are foreign corporate or foreign individuals, that are not QIBs or RIBs and who have applied for Equity Shares for an amount of more than ₹ 200,000 (but not including NRIs other than Eligible NRIs)
Other Investors	Investors other than Retail Individual Investors. These include individual applicants other than retail individual investors and other investors including corporate bodies or institutions irrespective of the number of specified securities applied for.
Overseas Corporate Body / OCB	Overseas Corporate Body means and includes an entity defined in clause (xi) of Regulation 2 of the Foreign Exchange Management (Withdrawal of General Permission to Overseas Corporate Bodies (OCB's) Regulations 2003 and which was in existence on the date of the commencement of these Regulations and immediately prior to such commencement was eligible to undertake transactions pursuant to the general permission granted under the Regulations. OCBs are not allowed to invest in this Issue.
Prospectus	The Prospectus, filed with the RoC in accordance with the provisions of Section 32 of the Companies Act, 2013.
Public Issue Account	The Bank Account opened with the Banker(s) to this Issue to receive monies from the Escrow Account and from the ASBA Accounts.
Qualified Institutional Buyers or QIBs	A Mutual Fund, Venture Capital Fund and Foreign Venture Capital investor registered with the Board, a foreign institutional investor and sub-account (other than a sub-account which is a foreign corporate or foreign individual), registered with the Board; a public financial institution as defined in Section 2(72) of the Companies Act, 2013; a scheduled commercial bank; a multilateral and bilateral development financial institution; a state industrial development corporation; an insurance company registered with the Insurance Regulatory and Development Authority; a provident fund with minimum corpus of ₹ 25.00 Crore; a pension fund with minimum corpus of ₹ 25.00 Crore rupees; National Investment Fund set up by resolution No. F. No. 2/3/2005 - DDII dated November 23, 2005 of the Government of India published in the Gazette of India, insurance funds set up and managed by army, navy or air force of the Union of India and insurance funds set up and managed by the Department of Posts, India.
Refund Account	The account opened with Refund Bank(s), from which refunds, if any, of the whole or part of the Application Amount (excluding to the ASBA Applicants) shall be made to the Applicants.
Refund Bankers	The bank(s) which is a/are clearing member(s) and registered with the SEBI as Bankers to the Issue, at which the Refund Accounts will be opened, in this case being HDFC Bank Limited.
Refunds through electronic transfer of funds	Refunds through NECS, NEFT, Direct Credit, RTGS, as applicable.
Registrar/ Registrar to this Issue/RTI	Sharex Dynamic (India) Private Limited, Unit -1, Luthra Ind. Premises, 1 st Floor, 44-E, M Vasanti Marg, Andheri-Kurla Rd., Safed Pool, Andheri (E), Mumbai - 400072
Registered Broker	Individuals or companies registered with SEBI as "Trading Members" (except Syndicate/Sub-Syndicate Members) who hold valid membership of either BSE or NSE having right to trade in stocks listed on Stock Exchanges, through which investors can buy or sell securities listed on stock exchanges, a list of which is available on http://www.bseindia.com/members/MembershipDirectory.aspx & http://www.nseindia.com/membership/dynaContent/find_a_broker.htm
Reserved Category/ Categories	Categories of persons eligible for making application under reservation portion.
Reservation Portion	The portion of the Issue reserved for category of eligible Applicants as provided under the

Bansal Roofing Products Limited

Term	Description
	SEBI ICDR Regulations, 2009
Retail Individual Investors/RIIs	Individual Bidders (including HUFs in the name of Karta and Eligible NRIs) who have applied for an amount less than or equal to ₹ 2,00,000.00 in this Issue.
Self Certified Bank or SCSB	A Bank which is registered with SEBI under SEBI (Bankers to an Issue) Regulations, 1994 and offers services of ASBA including blocking of bank account, a list of which is available on http://www.sebi.gov.in/pmd/scsb.pdf
Specified Cities	Cities as specified in the SEBI Circular No. CIR/CFD/DIL/1/2011 dated April 29, 2011, namely, Ahmedabad, Bangalore, Baroda (Vadodara), Chennai, Delhi, Hyderabad, Jaipur, Kolkata, Mumbai, Pune, Rajkot and Surat.
SME Exchange	SME Platform of the BSE Limited
Stock Exchange	BSE Limited
Underwriters	The Lead Manager and the Market Maker who have underwritten this Issue pursuant to the provisions of the SEBI (ICDR) Regulations and the SEBI (Underwriters) Regulations, 1993, as amended from time to time.
Underwriting Agreement	The Agreement dated April 5, 2014 entered into amongst the Underwriters and our Company.
Working Days	All days except Sunday and any public holiday (except in relation to the Issue Period where a working day means all days other than a Saturday, Sunday or a public holiday), on which commercial banks in Mumbai are open for business.

Technical and Industry Related Terms

Term	Description
BGM	Bare Galvalume
FRP	Fiber Reinforced Plastic
GI	Galvanized Iron
PP	Pre Painted
PPAL	Pre Painted Aluminium
PPGI	Pre Painted Galvanized Iron
PPGL	Pre Painted Galvalume
PVC	Poly Vinyl Chloride
SDT	Self Drilling cum Tapping Screws
TCT	Total Coated Thickness
U.V.	Ultra Violet

Abbreviations

Term	Description
A/c	Account
AGM	Annual General Meeting
AS	Accounting Standards issued by the Institute of Chartered Accountants of India.
A.Y.	Assessment Year
AoA	Articles of Association
ASBA	Application Supported by Blocked Amount
B.Com	Bachelor of Commerce
BG	Bank Guarantee
BSE	BSE Limited
CAGR	Compounded Annual Growth Rate
CC	Cash Credit
CDSL	Central Depository Services (India) Limited
CENVAT	Central Value Added Tax
CIN	Corporate Identity Number
CST	Central Sales Tax
DGFT	Directorate General of Foreign Trade
DIN	Director Identification Number
DIPP	Department of Industrial Policy & Promotion
DP	Depository Participant
DP ID	Depository Participant's Identification Number

Bansal Roofing Products Limited

Term	Description
ECS	Electronic Clearing System
EBIDTA	Earnings before Interest, Depreciation, Tax and Amortisation
EGM	Extraordinary General Meeting of the shareholders
EPFA	The Employees' Provident Funds and Miscellaneous Provisions Act, 1952
EPS	Earnings Per Share
ESIC	Employee's State Insurance Corporation
FCNR Account	Foreign Currency Non Resident Account
FDI	Foreign Direct Investment
FII(s)	Foreign Institutional Investor, as defined under the FII Regulations and registered with the SEBI under applicable laws in India
FII Regulations	Securities and Exchange Board of India (Foreign Institutional Investors) Regulations, 1995, as amended from time to time.
FIPB	Foreign Investment Promotion Board
FEMA	Foreign Exchange Management Act, 1999, as amended from time to time, and the Regulations framed there under
Financial Year/ Fiscal/ F.Y.	The period of twelve (12) months ended on March 31 of that particular year.
FI's	Financial Institutions
FTP	Foreign Trade Policy, 2009
FVCI	Foreign Venture Capital Investors registered with SEBI under the SEBI (Foreign Venture Capital Investor) Regulations, 2000.
GDP	Gross Domestic Product
GoI/Government	Government of India
HUF	Hindu Undivided Family
IFRS	International Financial Reporting Standards
Indian GAAP	Generally Accepted Accounting Principles in India
IPO	Initial Public Offer
IRDA	Insurance Regulatory and Development Authority
I. T. Act	The Income Tax Act, 1961, as amended.
IT Authorities	Income Tax Authorities
I. T. Rules	The Income Tax Rules, 1962, as amended, except as stated otherwise.
LC	Letter of Credit
MICR	Magnetic Ink Character Recognition
Mn	Million
MNC	Multi National Company
MoA	Memorandum of Association
MoF	Ministry of Finance, Government of India
MoU	Memorandum of Understanding
N.A.	Not Applicable
NAV	Net Asset Value
NECS	National Electronic Clearing System
NEFT	National Electronic Fund Transfer
NBFC	Non- Banking Finance Company
No.	Number
NoC	No Objection Certificate
NI Act	Negotiable Instruments Act, 1881
NRE Account	Non-Resident (External) Account
NRO Account	Non-Resident (Ordinary) Account
NSDL	National Securities Depository Limited
p.a.	Per annum
PAN	Permanent Account Number
PAT	Profit After Tax
P/E Ratio	Price/Earnings Ratio
QIB	Qualified Instructional Buyer
RBI	Reserve Bank of India
R & D	Research and Development
ROE	Return on Equity

Bansal Roofing Products Limited

Term	Description
RoC	Registrar of Companies
RONW	Return on Net Worth
RTGS	Real Time Gross Settlement
₹	Indian Rupees, the official currency of the Republic of India
SCRA	Securities Contract (Regulation) Act, 1956, as amended from time to time
SCRR	Securities Contracts Regulations Rules, 1957
SEBI	The Securities and Exchange Board of India constituted under the SEBI Act, 1992.
Sec.	Section
STT	Securities Transaction Tax
TAN	Tax Deduction Account Number
U.S.A. / United States / US / U.S.	United States of America
U.S. GAAP	Generally Accepted Accounting Principles in the United States of America
USD/US\$/ \$	United States Dollar
VAT	Value added tax
w.e.f.	With effect from
YoY	Year on Year

Notwithstanding the following:-

- (i) In the section titled '**Main Provisions of the Articles of Association**' beginning on page 201 of the Prospectus, defined terms shall have the meaning given to such terms in that section.
- (ii) In the section titled '**Financial Information of the Company**' beginning on page 113 of this Prospectus, defined terms shall have the meaning given to such terms in that section;
- (iii) In the Chapter titled "**Statement of Tax Benefits**" beginning on page 57 of the Prospectus, defined terms shall have the same meaning given to such terms in that chapter.

CERTAIN CONVENTIONS, USE OF FINANCIAL INFORMATION & MARKET DATA AND CURRENCY OF PRESENTATION

Certain Conventions

Unless otherwise specified or the context otherwise requires, all references to "India" in this Prospectus are to the Republic of India, together with its territories and possessions and all references to the "US", the "USA", the "United States" or the "U.S." are to the United States of America, together with its territories and possessions.

In this Prospectus, the terms "we", "us", "our", the "Company", "our Company", "Bansal Roofing Products Limited" and "BRPL", unless the context otherwise indicates or implies, refers to Bansal Roofing Products Limited. In this Prospectus, unless the context otherwise requires, all references to one gender also refers to another gender and the word "Lakh/Lacs" means "one hundred thousand", the word "million (mn)" means "ten lakh", the word "Crore" means "ten million" and the word "billion (bn)" means "one hundred crore". In this Prospectus, any discrepancies in any table between total and the sum of the amounts listed are due to rounding-off.

Financial Data

Unless stated otherwise, the financial data in this Prospectus is derived from our restated financial statement for the F.Y. ended as on March 31, 2013, 2012, 2011, 2010 and 2009 and 9 months period ended on December 31, 2013. Our restated and financial statements are based on our audited financial statements respectively prepared in accordance with Indian GAAP, the Accounting Standards and other applicable provisions of the Companies Act and are restated in accordance with the SEBI (ICDR) Regulations. Our fiscal year commences on April 1 and ends on March 31 of the next year, so all references to a particular fiscal year are to the twelve-month (12) period ended March 31 of that year. In this Prospectus, any discrepancies in any table between the total and the sums of the amounts listed are due to rounding-off.

All the numbers in this Prospectus have been presented in Lakhs, Millions and Crores or in whole numbers where the numbers have been too small to present in Lakhs.

There are significant differences between Indian GAAP, U.S. GAAP and the International Financial Reporting Standards (IFRS). Accordingly, the degree to which the Indian GAAP restated financial information included in this Prospectus will provide meaningful information is entirely dependent on the reader's level of familiarity with Indian accounting practices. Any reliance by persons not familiar with Indian accounting practices on the financial disclosures presented in this Prospectus should accordingly be limited. We have not attempted to explain those differences or quantify their impact on the financial data included herein, and we urge you to consult your own advisors regarding such differences and their impact on our financial data.

Any percentage amounts, as set forth in the sections titled "*Risk Factors*", "*Our Business*", "*Management's Discussion and Analysis of Financial Condition and Results of Operations*" beginning on page no. 11, 72 and 142 respectively of this Prospectus, unless otherwise indicated, have been calculated on the basis of our restated financial information prepared in accordance with Indian GAAP.

For definitions, please refer to the section titled "*Definitions and Abbreviations*" beginning on page no. 1 of this Prospectus. In the section entitled "*Main Provisions of the Articles of Association*" beginning on page no. 201 of this Prospectus, defined terms have the meaning given to such terms in the Articles.

Use of Industry and Market data

Unless stated otherwise, the industry and market data and forecasts used throughout this Prospectus has been obtained from industry sources as well as Government Publications. Industry sources as well as Government Publications generally state that the information contained in those publications has been obtained from sources believed to be reliable but that their accuracy and completeness and underlying assumptions are not guaranteed and their reliability cannot be assured.

Further, the extent to which the industry and market data presented in this Prospectus is meaningful depends on the reader's familiarity with and understanding of the methodologies used in compiling such data. There are no standard data gathering methodologies in the industry in which we conduct our business, and methodologies and assumptions may vary widely among different industry sources.

Currency of Presentation and Exchange Rates

All references to "Rupees" or "₹" or "INR" are to Indian Rupees, the official currency of the Republic of India. Throughout this Prospectus all figures have been expressed in Lakhs/Lacs, Million and Crores. The word "Lakhs/Lacs" or "Lakh/Lac" means "One hundred thousand", "Million" means "Ten Lakhs" and "Crores" means "Ten Million".

Any percentage amounts, as set forth in "Risk Factors", "Business", "Management's Discussion and Analysis of Financial Conditions and Results of Operation" in this Prospectus, unless otherwise indicated, have been calculated based on our restated financial statement prepared in accordance with Indian GAAP.

This Prospectus contains conversions of certain US Dollar and other currency amounts into Indian Rupees that have been presented solely to comply with the requirements of the SEBI (ICDR) Regulations. These conversions should not be construed as a representation that those US Dollar or other currency amounts could have been, or can be converted into Indian Rupees, at any particular rate.

FORWARD LOOKING STATEMENTS

All statements contained in this Prospectus that are not statements of historical fact constitute forward-looking statements. All statements regarding our expected financial condition and results of operations, business, plans and prospects are forward-looking statements. We have included statements in this Prospectus which contain words or phrases such as "will", "aim", "is likely to result", "believe", "expect", "will continue", "anticipate", "estimate", "intend", "plan", "contemplate", "seek to", "future", "objective", "goal", "project", "should", "will pursue" and similar expressions or variations of such expressions, that are "forward-looking statements".

All forward looking statements are subject to risks, uncertainties and assumptions about us that could cause actual results to differ materially from those contemplated by the relevant forward-looking statement. Forward-looking statements reflect our current views with respect to future events and are not a guarantee of future performance. These statements are based on our management's beliefs and assumptions, which in turn are based on currently available information. Although we believe the assumptions upon which these forward-looking statements are based are reasonable, any of these assumptions could prove to be inaccurate, and the forward-looking statements based on these assumptions could be incorrect. Important factors that could cause actual results to differ materially from our expectations include but are not limited to:

1. General economic and business conditions in India and in the markets in which our company operate and in the local, regional, national and international economies;
2. Increased competition in these sectors/areas in which we operate;
3. Changes in laws and regulations relating to the industry in which we operate;
4. Our ability to compete with and adapt to the technological advances;
5. Changes in political, economic and social conditions in India;
6. Fluctuations in the operating costs;
7. Changes in the foreign exchange control regulations, interest rates and tax laws in India;
8. Our ability to attract and retain qualified personnel;
9. Our ability to meet our capital expenditure requirements; and
10. Any adverse outcome in the legal proceedings in which we may be involved.
11. Market fluctuations and industry dynamics beyond our control;
12. Occurrence of natural disasters or calamities affecting the areas in which we have operations;
13. Conflicts of interest with affiliated companies, the promoter group and other related parties; and
14. Contingent Liabilities, environmental problems and uninsured losses;

For a further discussion of factors that could cause our actual results to differ from our expectations, please refer to the sections titled "***Risk Factors***", "***Our Business***" and "***Management's Discussion and Analysis of Financial Condition and Results of Operations***" beginning on page no. 11, 72 and 142 respectively, of this Prospectus. By their nature, certain market risk disclosures are only estimates and could be materially different from what actually occurs in the future. As a result, actual future gains or losses could materially differ from those that have been estimated.

Forward looking statements speak only as of the date of this Prospectus. Neither our Company, our Directors and officers, the Underwriters, nor any of our respective affiliates or associates has any obligation to update or otherwise revise any statements reflecting circumstances arising after the date hereof or to reflect the occurrence of underlying events, even if the underlying assumptions do not come to fruition. In accordance with SEBI requirements, our Company and the Lead Manager will ensure that investors in India are informed of material developments until the final listing and commencement of trading of the Equity Shares allotted pursuant to the Issue on the Stock Exchanges.

SECTION II: RISK FACTORS

RISK FACTORS

An investment in Equity involves a high degree of risk. Investors should carefully consider all the information in this Prospectus, including the risks and uncertainties described below, before making an investment in our Equity Shares. Any of the following risks as well as other risks and uncertainties discussed in this Prospectus could have a material adverse effect on our business, financial condition and results of operations and could cause the trading price of our Equity Shares to decline, which could result in the loss of all or part of your investment. In addition, the risks set out in this Prospectus may not be exhaustive and additional risks and uncertainties, not presently known to us, or which we currently deem immaterial, may arise or become material in the future. Unless otherwise stated in the relevant risk factors set forth below, we are not in a position to specify or quantify the financial or other risks mentioned herein.

Materiality

The Risk factors have been determined on the basis of their materiality. The following factors have been considered for determining the materiality.

1. Some events may not be material individually but may be found material collectively.
2. Some events may have material impact qualitatively instead of quantitatively.
3. Some events may not be material at present but may be having material impact in future.

Note:

The risk factors as envisaged by the management along with the proposals to address the risk if any. Unless specified or quantified in the relevant risk factors below, we are not in a position to quantify the financial implication of any of the risks described in this section.

In this Prospectus, any discrepancies in any table between total and the sums of the amount listed are due to rounding off. Any percentage amounts, as set forth in "**Risk Factors**" on page 11 and "**Management Discussion and Analysis of Financial Condition and Results of Operations**" on page 142 of this Prospectus unless otherwise indicated, has been calculated on the basis of the amount disclosed in the "Audited Financial Statements, as restated" prepared in accordance with the Indian Accounting Standards.

INTERNAL RISK FACTORS

1. ***Our Company, our Promoter and one of our Promoter Group Entities are involved in certain legal proceedings, which if determined, against the above entities could have adverse impact on the business and financial results of our Company.***

Our Company, our Promoter and one of our Promoter Group Entities are involved in certain legal proceedings, which if determined, against the above entities could have adverse impact on the business and financial results of our Company. These proceedings are pending at different levels before various courts, tribunals, affiliate tribunals, enquiry officers, etc. For details kindly refer chapter titled "**Outstanding Litigation and Material Developments**" at page no. 151.

A classification of the legal proceedings instituted against and by our Promoter, one of our Directors and certain Group Companies, the monetary amount involved, wherever quantifiable, in these cases is mentioned in brief below.

Litigation against Our Company		
Nature of Cases	Nos. of outstanding Cases	Amount involved (₹)
Civil	2	Not ascertainable
Income Tax Demand Notices	1	6,660.00
Civil Notices	1	Not ascertainable
Total	4	6,660.00

Litigation by Our Company		
Nature of Cases	Nos. of outstanding Cases	Amount involved (₹)
Civil	1	Not ascertainable
Company Law Matter	1	Not ascertainable
Total	2	Not ascertainable

Litigation against Promoter and Promoter group entity of our Company		
Nature of Cases	Nos. of outstanding Cases	Amount involved (₹)
Income Tax Demand Notices	1	1,46,780.00
Total	1	1,46,780.00

Litigation by Promoter and Promoter group entity of our Company		
Nature of Cases	Nos. of outstanding Cases	Amount involved (₹)
Civil	1	3,69,353.00
Criminal	2	Not ascertainable
Tax	1	2,11,141.00
Total	4	5,80,494.00

Note: All amounts mentioned above are approximate.

We cannot provide any assurance that these matters will be decided in favour of the above mentioned entities or persons. Further, there is no assurance that similar proceedings will not be initiated against the above mentioned entities or persons in the future.

2. *Our Company has availed of financial facility in the nature of Cash Credit of ₹200.00 Lakhs from State Bank of India, which includes several restrictive covenants, for which prior written approval of Bank would be required. Failure to adhere to the said covenants or non-compliance of some or any of them or delay by the Bank in granting such approval may hinder us from taking advantage of a dynamic market environment or may even result in revocation of the said financial facility which in turn may adversely affect our business operations and financial condition.*

Presently, we have entered into agreement for availing financial facility in the nature of Cash Credit from State Bank of India, which is currently outstanding as at December 31, 2013 at ₹ 55.51 Lakhs. Certain covenants in this agreement require us to obtain approval / permission from our above lender under certain conditions. These restrictive covenants inter alia includes, among others the following:

- a. The Bank shall recover commitment charges in the event of underutilization of sanctioned limit of ₹ 200.00 Lacs
- b. The sanctioned limits are valid till August 30, 2014 and the renewal shall be subject to review thereon.
- c. All monies raised by way of deposits from directors/ promoters/ friends, relatives and /or from any other sources should not be withdrawn / repaid during the currency of the Bank's advance.
- d. Penal interest rate at 1% cumulatively subject to a maximum of 2% shall be charged for a delay in respect of non-submission or delayed submission of financial data/ stock statements/ excess drawing or irregularity.
- e. The Company shall have to seek the NOC of the Bank for the following purposes:
 - Changing the Capital structure
 - Implementation of any scheme of expansion/ modernization / diversification / renovation/ acquisition of fixed assets except those already approved by the Bank.
 - Formulate any scheme of amalgamation or reconstruction.
 - Enter into borrowing arrangements either secured / unsecured / with any other bank / Financial Institutions/ company / persons.
 - Declare dividend for any year except out of profits relating to that year after meeting all the re-payment obligations.
 - Effect any drastic change in the management.
 - Effect any change in the remuneration payable to the directors.
 - Create any further charge, lien or encumbrance upon or sell, assign or otherwise dispose off the assets and properties of the Company / guarantor, that have been charged by the bank.
 - Undertake any trading activity other than the sale of produce arising out of its own manufacturing / trading operations.

In the event of default or the breach of certain covenants, our lender has the option to make the entire outstanding amount payable immediately. There can be no assurance that we will be able to comply with these financial or other covenants or that we will be able to obtain consents from the financial institutions in a timely manner or at all. . The time required to secure consents may hinder us from taking advantage of a dynamic market environment. Failure by the bank to grant such consents may even compel the Company to repay such loans on a short notice. For further details in this regard, please refer to section titled “**Financial Indebtedness**” on page 194 of the Prospectus.

3. Our Company does not own Registered Office from which we currently operate.

Our Company does not own our registered office premise situated at 3/2, Labdhi Industrial Estate, Acid Mill Compound, Ranmukteshwar Road, Pratapnagar, Vadodara – 390004, Gujarat, India. Our Company acquired this premise from our Promoter, Mrs. Sangeeta K. Gupta vide Rent Agreement dated April 1, 2013 for a period of 11 months starting from the date of Agreement at consideration of ₹ 15,000.00 per month. The said rent agreement has been renewed on March 1, 2014 for further 11 months and can be renewed further on the basis of mutual consent. However, there is no assurance in future that the landlords of such premises may be willing to renew such agreements on similar terms or renew such agreements at all. Consequently we may have to vacate the said premises in a limited period of time and we may not be able to arrange for an alternative work place in the given time. This may adversely affect our day to day operations and thus our profitability could be adversely impacted.

4. We require number of approvals, licenses, registration and permits for our business and failure to obtain or renew them in a timely manner may adversely affect our operations.

We require several statutory and regulatory permits, licenses and approvals to operate in the manufacturing business, some of which our Company has either received, applied for or is in the process of application. Many of these approvals are granted for fixed periods of time and need renewal from time to time. Non-renewal of the said permits and licenses would adversely affect our Company’s operations, thereby having a material adverse effect on our business, results of operations and financial condition. There can be no assurance that the relevant authorities will issue any of such permits or approvals in the time-frame anticipated by us or at all. Our Company requires certain statutory and regulatory registrations, licenses, permits and approvals for our business. The brief details are mentioned here under:

Nature of License / Approval	Registration/ License No.	Issuing Authority	Date of Application for renewal	Validity
Factories License	13613	Joint Director, Directorate Industrial Safety & Health Gujarat State, Vadodara	October 23, 2013	Expired on December 31, 2013), Applied, Pending for renewal.

For Certificate of Registration under the Contract Labour (Regulation & Abolition) Act, 1970, Employees Provident Fund Registration and Tax Deduction Account Number (TAN) on change of name of our Company pursuant to Conversion from private to public Company, we have applied to the relevant issuing authority for issuance of new certificates in the new name. However we are yet to receive the fresh certificates.

We may be penalized for non compliance of the above laws for which we have not obtained Licenses. Further, some of our permits, licenses and approvals are subject to several conditions and we cannot provide any assurance that we will be able to continuously meet such conditions or be able to prove compliance with such conditions to the statutory authorities, which may lead to the cancellation, revocation or suspension of relevant permits, licenses or approvals. Any failure by us to apply in time, to renew, maintain or obtain the required permits, licenses or approvals, or the cancellation, suspension or revocation of any of the permits, licenses or approvals may result in the interruption of our operations and may have a material adverse effect on the business. If we fail to comply with all applicable regulations or if the regulations governing our business or their implementation change, we may incur increased costs, be subject to penalties or suffer a disruption in our business activities, any of which could adversely affect our results of operations. For further details, please see chapters titled “**Key Industry Regulations and Policies in India**” and “**Government and Other Approvals**” at pages 82 and 157 respectively of this Prospectus

5. Any penalty or action taken by any regulatory authorities in future for non-compliance with provisions of corporate and other law could impact the financial position of the Company to that extent.

Our Company may have not complied with provisions of Section 211 of Companies Act, 1956 and accounting standards 15, 18 & 22 and Section 4A of The Payment of Gratuity Act, 1972, in the past. Although no show cause notice in respect of the same has been received by the Company till date, the Company has jointly with the Managing Director and the officers in default, for the period of such default, applied for compounding of the default under Section 621A of the Companies Act, 1956 with the appropriate authority through Regional Director, North Western Region Branch, Ahmedabad of Registrar of Companies and any penalty imposed for such non-compliance on the compounding of the default could affect our financial conditions to that extent. For further details on the same please refer section “**Outstanding Litigation and Material Developments**” beginning on page no. 151. In relation to gratuity we have not received any notice/communication from the relevant authority, for the previous defaults till date. However we have created a specified fund with Life Insurance Corporation of India from March 01, 2014.

6. We have experienced negative cash flows in previous years. Any operating losses or negative cash flows in the future could adversely affect our results of operations and financial conditions.

The details of Cash flows of the Company are as follows:

Particulars	For the period/ year Ended 31 st of					
	December 2013	March 2013	March 2012	March 2011	March 2010	March 2009
Net cash (used in) / from Operating Activities	14220438.64	(11210122.00)	(387419.95)	(86443.00)	21856.78	109118.30
Net cash (used in) / from Investing Activities	(6632304.65)	(1312004.03)	(14151339.05)	0.00	0.00	(99750.00)
Net cash (used in) / from Financing Activities	(4187484.51)	12418533.00	14390726.25	699724.25	(80000.00)	148011.23
Net increase / (decrease) in cash and cash equivalents	3400649.48	(103593.03)	(148032.75)	613281.25	(58143.22)	157379.53

Cash flow of a Company is a key indicator to show the extent of cash generated from operations to meet capital expenditure, pay dividends, repay loans and to make new investments without raising finance from external resources. Any operating losses or negative cash flows could adversely affect our results of operations and financial conditions. If we are not able to generate sufficient cash flows, it may adversely affect our business and financial operations. For more information, regarding Cash flows, please refer **Annexure III** in chapter titled “**Financial Information of the Company**” beginning on page 113 of this Prospectus.

7. We have not received registration certificate for our corporate logo  but we are using it as our trademark in our communications viz. Letterheads, Banner and other material.

Our Corporate logo  is under the process of registration with Trade Marks Registry. We have applied for the registration of the same on March 6, 2014 Class 19 and 6 through application nos. 2693319 and 2693320 respectively. As of now we are waiting for the registration certificate. The registration of any trademark is a time consuming process and there can be no assurance that any such registration will be granted. Our applications for the registration of these trademarks may be opposed by third parties, and we may have to incur significant cost in relation to these oppositions. In the event we are not able to obtain registrations or if any injunctive or other adverse order is issued against us in respect of any of our trademarks for which we have applied for registration, we may not be able to avail the legal protection and legal remedies (in case of infringement) or prohibit unauthorized use of such trademarks by third parties by means of statutory protection, available as a proprietor of registered trademarks, which may materially and adversely affect our goodwill and business. We cannot provide any assurance that third parties will not infringe upon our trademark, trade names logos or brand names, and thereby cause damage to our business prospects, reputation or goodwill. The artistic work, in the logo, used by our Company has not been registered under the Copyright Act, 1957.

Further our Company has not applied for registration of our trade name under the provisions of the Trademarks Act in Class 35 for retail trading. In future, if our Company enter into the trading of the goods manufactured by it, there is no surety that the Company shall be able to protect its trade name in class 35.

8. ***There is no monitoring agency appointed by our Company and the deployment of funds are at the discretion of our Management and our Board of Directors, though it shall be monitored by our Audit Committee.***

As per SEBI (ICDR) Regulations, 2009, as amended, appointment of monitoring agency is required only for Issue size above ₹ 50,000 Lakhs. Hence, we have not appointed any monitoring agency to monitor the utilization of Issue proceeds. However, the audit committee of our Board will monitor the utilization of Issue proceeds in terms of Clause 52 of SME Listing Agreement. Further, our Company shall inform about material deviations in the utilization of Issue proceeds to the BSE Limited and shall also simultaneously make the material deviations / adverse comments of the audit committee public.

9. ***Promoter Group Entities are engaged in the line of business similar to our Company. There are no non - compete agreements between our Company and Promoter Group Entities. We cannot assure that our Promoters will not favour the interests of such Entities over our interest or that the said entities will not expand which may increase our competition, which may adversely affect business operations and financial condition of our Company.***

Our promoter Mr. Kaushalkumar S. Gupta and Mrs. Sangeeta K. Gupta has promoted Agrawal Associates and Bansal Roofing Products which are engaged in the similar line of business as of our Company. Further, we have not entered into any non-compete agreement with any of our said entities. We cannot assure you that our Promoters who have common interest in said entities will not favour the interest of the said entities or such entities will not expand, which may adversely affect our profitability and results of operations. For further details, please refer to para “**Common Pursuits**” on 110 of this Prospectus.

10. ***Our Company has taken an interest free unsecured loan from one of our Promoter Director Mr. Kaushalkumar S. Gupta, The total outstanding amount of which as on December 31, 2013 is ₹ 82.00 Lacs. The MoU as entered between our Company and the Promoter, which provides for a notice of 3 months for its re-payment. However, in case our Promoter recalls the said loan, it may have an adverse affect on our cash flow and financial condition.***

Our Promoter Mr. Kaushalkumar S. Gupta had given an interest free unsecured loan to our Company. The total outstanding amount of which as at December 31, 2013 was ₹ 82.00 Lacs. The MoU as entered between our Company and the Promoter, which provides for a notice of 3 months for its re-payment. Although our Company presently has sufficient provisions to pay back the loan, if the loan is recalled on a short notice, our Company may have to, on an urgent basis arrange for equivalent funds to fulfill the necessary requirements. Inability of our Company to do so may require creating a security for such loan. The occurrence of these events may have an adverse effect on our cash flow and financial conditions. For more details regarding the loan, please refer the chapter titled “**Financial Information of the Company**” beginning on page 113 of this Prospectus.

11. ***Our Promoters, Director and immediate relative of our Director have given personal guarantees in relation to Cash Credit facility provided to our Company by State Bank of India. In event of default on the debt obligations, the personal guarantees may be invoked thereby adversely affecting our Promoter’s, Director’s ability to manage the affairs of our Company and consequently the impact our business, prospects, financial condition and results of operations.***

Our Company has availed of Cash Credit facilities of ₹ 200.00 Lakhs from State Bank of India to our Company, for which the outstanding amount as on December 31, 2013 at ₹ 55.51 Lakhs. Terms and conditions of the said facility stipulate that the facility shall be secured by a personal guarantee of our Promoters, Directors. In event of default on the debt obligations, the personal guarantees may be invoked thereby adversely affecting our Promoters’ ability to manage the affairs of our Company and consequently the impact our business, prospects, financial condition and results of operations

12. ***We are highly dependent on our Top 10 suppliers for uninterrupted supply of raw-materials. Any disruption in supply of raw materials from these suppliers will adversely affect our operations.***

We are highly dependent on colour coated steel rolls and aluminium, which are the prime raw material for our products. We procure our supply of raw materials from various suppliers depending upon the price and quality of raw materials. However our Top 10 supplier contributes significantly to supply of raw materials. Any disruption of supply

Bansal Roofing Products Limited

of raw materials from these suppliers will adversely affect our operations. The contributions of our top 10 suppliers are as follows:

Particulars	For 9 months ended December 31, 2013	Year ended March 31, 2013
Top Supplier	64.78%	72.05%
Top 10 Supplier	97.98%	99.95%

- 13. Our business is substantially dependent on certain key clients from whom we derive a significant portion of our revenues. The loss of any significant clients may have a material and adverse effect on our business and results of operations.**

While we are constantly striving to increase our customer base and reduce dependence on any particular customer, there is no assurance that we will be able to broaden our customer base in any future periods, or that our business or results of operations will not be adversely affected by a reduction in demand or cessation of our relationship with any of our major customers. Also we are highly dependent on one customer who significantly contributes to our revenues. The percentage of sales derived from top customers in recent periods is given below:

Particulars	For 9 months ended December 31, 2013	Year ended March 31, 2013
Sales to Top Customer	21.52%	68.87%
Sales to Top 10 Customers	35.37%	89.08%

- 14. Our operations are significantly concentrated in Gujarat and failure to expand our Operations may restrict our growth and adversely affect our business.**

At present, our manufacturing facilities are carried from Vadodara. We do not have any other branches/ factories apart from our factory at Vadodara in Gujarat. As on date of this Prospectus, our operations are mainly focused in Gujarat. We believe that our future growth in business and revenues will be achieved only through a pan-India footprint.

- 15. Our Company had entered into various transactions with our Promoters, Promoter Group, Directors and their Relatives and Group Companies. Our Company in the past has entered into Related Party Transactions and may continue to do so in future also, which may adversely affect our competitive edge and better bargaining power had these transactions have been entered with non-related parties resulting into relatively more favorable terms and conditions and better margins.**

Our Company, had entered into various transactions with our Promoters, Promoter Group, Directors and their Relatives and Group Companies. These transactions, inter-alia includes sale/purchase of goods, payment for services received/rendered, remuneration, etc. Our Company entered into such transactions due to easy proximity and quick execution. However, there is no assurance that we could not have obtained better and more favorable terms had our Company not entered into such related party transactions. Our Company may enter into such transactions in future also and we cannot assure that in such that event there would be no adverse affect on results of our operations. For details please refer to **Annexure N on Related Party Transactions** of the Auditor’s Report under Section titled “**Financial Information of the Company**” beginning on page 134 of this Prospectus.

- 16. Our insurance coverage may not adequately protect us against certain operating risks and this may have as adverse effect on the results of our business.**

We are insured for a number of the risks associated with our manufacturing business, through policies such as Standard Fire and Allied Perils Insurance, Workman Compensation Insurance, Burglary (House Breaking) Insurance, Marine Cargo Open Policy-Inland. We believe we have got our assets adequately insured; however there can be no assurance that any claim under the insurance policies maintained by us will be honoured fully, in part or on time, to cover all material losses. To the extent that we suffer any loss or damage that is not covered by insurance or exceeds our insurance coverage, our business and results of operations could be adversely affected. We may also be subject to claims resulting from defects in the engineering design and commissioning of our products. Our policy of covering these risks through insurance may not always be effective or adequate. Failure to effectively cover ourselves against the associated risks for any of these reasons including other unforeseen circumstances could expose us to substantial costs and potentially lead to material losses. Faults in designing and installation might also require repair work, which may not be foreseen or covered by our insurance. In addition, if there is a customer dispute regarding our performance or workmanship, the customer may delay or withhold payment to us. For details on insurance policies taken by our Company please page no. 81 in chapter titled “**Our Business**”.

- 17. We require high working capital for our smooth day to day operations of business and any discontinuance or our inability to acquire adequate working capital timely and on favorable terms may have an adverse affect on our operations, profitability and growth prospects.***

We operate in a capital intensified industry therefore our business demands substantial funds towards working capital requirements. In case there are insufficient cash flows to meet our working capital requirement or we are unable to arrange the same from other sources or there are delays in disbursement of arranged funds, or we are unable to procure funds on favorable terms, it may result into our inability to finance our working capital needs on a timely basis which may have an adverse effect on our operations, profitability and growth prospects.

- 18. The success of our business operations depends largely upon our Promoter Directors and Key Managerial Personnel, the loss of any of them may negatively impact our business operations and financial conditions.***

Our success is highly dependent on the expertise and services of our Promoter Directors, Mr. Kaushalkumar S. Gupta, Mrs. Sangeeta K. Gupta and key managerial personnel. Our ability to successfully function and meet future business challenges partly depends on our ability to attract and retain these key managerial personnel. We cannot assure you that we will be able to retain any or all of the key members of our management. The loss of the services of any key member of our management team could have an adverse effect on our ability to implement new projects and expand our business. For further details of our Promoter Directors and key managerial personnel, please refer to the section “***Our Management***” on page 93 of the Prospectus.

- 19. We have not entered into any long term supply agreement for the major raw materials required for manufacturing of our products. Also volatility in the prices and non availability of these raw materials may have an adverse impact in our business.***

We depend highly on colour coated steel rolls and aluminium, which are the prime raw materials for our products. We generally procure these raw materials from indigenous suppliers as and when required. Any fluctuation in the international prices of these metals affects the price and supply of these raw materials. Therefore, any significant increase in the prices of these raw materials due to any reason, and our inability to pass on increased costs of raw material to our customers or reduction in demand from our customers, may adversely affect our sales and profitability. In the absence of any long-term arrangement with suppliers and event of any disruption in the supply of raw materials supply in terms of requisite quantities and qualities, our production schedule may also be adversely affected.

- 20. The Company is promoted by first generation entrepreneurs.***

Our Promoters are first generation entrepreneur. Their experience in managing and being instrumental in the growth of our Company is limited to the extent of their knowledge and experience and we cannot assure that this will not affect our business growth.

- 21. Our Promoters and Directors may have interest in our Company, other than reimbursement of expenses incurred or remuneration.***

Apart for receipt of remuneration and re-imbusement of expenses incurred by them, our Promoters and Directors and key management personnel may be deemed to be interested to the extent of the Equity Shares held by them, or their relatives or our Group Entities, and benefits deriving from their directorship in our Company. Our Promoters and directors are interested in the certain transactions entered into between our Company and themselves as well as between our Company and our Group Entities. For further details, please refer to the chapters titled “***Our Business***” and “***Our Promoters***”, beginning on page 72 and 105 respectively and the ***Annexure N titled “Related Party Transactions”*** under chapter titled “***Restated Financial statements***” beginning on page 134 of this Prospectus.

- 22. Delay in raising funds from the IPO could adversely impact our Cash flows and results of operations.***

The object of our proposed Initial Public Issue, as detailed in the section titled “***Objects of the Issue***” is to get long term working capital. Any failure or delay on our part to mobilize the required funds from the Issue Proceeds may adversely affect our cash flows and results of operations.

23. Any change in interest rates and banking policies may have an adverse impact on our Company's operations and profitability.

Our Company has taken Cash Credit facility from State Bank of India ₹ 200.00 Lakhs and is dependent on the same for arranging the long term financing for its business operations. Accordingly, any change in the existing banking policies or increase in interest rates may have an adverse impact on the Company's operations and profitability.

24. Our manufacturing activities are dependent upon availability of skilled and unskilled labour.

Except for the agreement our Company has entered with Carewell Services, Vadodara for supply of manpower at our manufacturing facility, we do not have any permanent arrangement of labour and recruitments are made on as per requirements. Our manufacturing activities are dependent on availability of skilled and unskilled labour. Non-availability of labour at any time or any disputes with them may affect our production schedule and timely delivery of our products to customers which may adversely affect our business and result of operations.

25. Our business is subject to various operating risks at our factory, the occurrence of which can affect our results of operations and consequently, financial condition of our Company.

Our business operations are subject to operating risks, such as breakdown or failure of equipments used at our factory, interruption in power supply, shortage of consumables, performance below expected levels of output or efficiency, natural disasters, obsolescence, labour disputes, industrial accidents, our inability to respond to technological advancements and emerging realty industry standards and practices along with the need to comply with the directives of relevant government authorities. The occurrence of these risks, if any, could significantly affect our operating results, and the slowdown / shutdown of business operations may have a material adverse affect on our business operations and financial conditions.

26. Our results of operations could be adversely affected by strikes, work stoppages or increased wage demands by our employees or other disputes with our employees or our contractors' employees.

Our operations are dependent on labour force. None of our employees are affiliated with any labour unions. However, there can be no assurance that our employees will not form a union, join any existing union or otherwise organize themselves. India has stringent labour legislation that protects the interests of workers, including legislation that sets forth detailed procedures for the establishment of unions, dispute resolution and employee removal and legislation that imposes certain financial obligations on employers upon retrenchment. Although, we currently have harmonious relations with our employees and they are not unionized at present, there can be no assurance that we will continue to have such relations. If our relations with our employees are strained, it may become difficult for us to maintain our existing labour policies, and our business may be adversely affected.

27. We have derived industry report from India Brand Equity Foundation "IBEF" and other government ministry reports.

We have referred the data , figures, charts, tables, graphs etc. from third party agencies and other ministry reports. Information which have been included on the Steel Industry in the Prospectus is taken from the website of IBEF. While deriving information on Indian economy we have relied on various reports from Indian Government Ministry. The information provided on/in the website of IBEF and reports from Indian Government Ministry is subject to various limitations and based upon certain assumptions that are subjective in nature. There can be no assurance that the assumptions adopted for such information by IBEF and government industries for preparing their reports will prove to be accurate. If any of these assumptions are incorrect, the understanding of the industry in India could be materially different from that set forth in the reports.

B. Risks Related To Our Equity Shares and Equity Share Holders

28. Our Promoters, together with our Promoter Group, will continue to retain majority shareholding in our Company after the proposed Initial Public Issue, which will allow them to exercise significant control over us. We cannot assure you that our Promoters and Promoter Group members will always act in the best interests of the Company.

After the completion of our Initial Public Issue, our Promoters, along with our Promoter Group members, will hold, approximately 67% of post issue paid up equity capital of our Company. As a result, our Promoters will continue to exercise significant control over us, including being able to control the composition of our Board and determine

matters requiring shareholder approval or approval of our Board. Our Promoters may take or block actions with respect to our business, which may conflict with our interests or the interests of our minority shareholder. By exercising their control, our Promoters could delay, defer or cause a change of our control or a change in our capital structure, delay, defer or cause a merger, consolidation, takeover or other business combination involving us, discourage or encourage a potential acquirer from making a tender offer or otherwise attempting to obtain control of our Company. We cannot assure you that our Promoters and Promoter Group members will always act in our Company's or your best interests. For further details, please refer to the chapters titled "***Capital Structure***" and "***Our Promoter Group and Promoter Group Entities***" beginning on page 39 and 108 respectively, of this Prospectus.

29. Our Company has not paid dividends in the past. There is no guarantee that we will be able to pay dividends in the future.

Our Company has not paid any dividend (including any interim dividend) on its shares since its inception. Further, our ability to pay dividends in the future will depend upon a variety of factors, including our future earnings, financial condition, cash flows, working capital requirements, capital expenditure and restrictive covenants in our financing arrangements, if any. As a result, we cannot assure you that we will make dividends of any particular amount, with any particular frequency or at all.

30. Any future issuance of Equity Shares may dilute your shareholdings, and sales of the Equity Shares by our major shareholders may adversely affect the trading price of our Equity Shares.

Any future equity issuances by our Company may lead to the dilution of investors' shareholdings in our Company. In addition, any sale of substantial Equity Shares in the public market after the completion of this Issue, including by our major shareholders, or the perception that such sales could occur, could adversely affect the market price of the Equity Shares and could significantly impair our future ability to raise capital through offerings of the Equity Shares. We cannot predict what effect, if any, market sales of the Equity Shares held by the major shareholders of our Company or the availability of these Equity Shares for future sale will have on the market price of our Equity Shares.

31. You may be subject to Indian taxes arising out of capital gains on sale of Equity Shares.

Under current Indian tax laws and regulations, capital gains arising from the sale of Equity Shares in an Indian Company are generally taxable in India. Any gain realized on the sale of listed Equity Shares on a stock exchange held for more than 12 months will not be subject to capital gains tax in India if Securities Transaction Tax ("***STT***") has been paid on the transaction. STT will be levied on and collected by a domestic stock exchange on which the Equity Shares are sold. Any gain realised on the sale of Equity Shares held for more than 12 months to an Indian resident, which are sold other than on a recognized stock exchange and on which no STT has been paid, will be subject to long term capital gains tax in India. Further, any gain realized on the sale of listed Equity Shares held for a period of 12 months or less will be subject to short term capital gains tax in India. For more details, please refer to "***Statement of Tax Benefits***" on page 57 of this Prospectus.

32. We cannot assure you that our Equity Shares will be listed on the SME Platform of BSE in a timely manner or at all, which may restrict your ability to dispose of the Equity Shares.

In terms of Chapter XB of the SEBI (ICDR) Regulations, 2009, as amended from time to time, we are not required to obtain any in-principle approval for listing of our Equity Shares issued. We have only applied to BSE Limited to use its name as the Stock Exchange in this Offer Document for listing our Equity Shares on the SME Platform of BSE Limited. Permission for listing of the Equity Shares will be granted only after the Equity Shares offered in this Issue have been allotted. Approval from BSE Limited will require all relevant documents authorizing the issuing of the Equity Shares to be submitted to it. There could be a failure or delay in listing the Equity Shares on the SME Platform of BSE. Further, certain procedural and regulatory requirements of SEBI and the Stock Exchanges are required to be completed before the Equity Shares are listed and trading commences. Trading in the Equity Shares is expected to commence within 12 Working Days from the Issue Closing Date. However, we cannot assure you that the trading in the Equity Shares will commence in a timely manner or at all. Any failure or delay in obtaining the approvals would restrict your ability to dispose off your Equity Shares.

33. *The price of our Equity Shares may be volatile, or an active trading market for our Equity Shares may not develop.*

Prior to this Issue, there has been no public market for our Equity Shares. Hem Securities Limited is acting as Market Maker for the Equity Shares of our Company. However, the trading price of our Equity Shares may fluctuate after this Issue due to a variety of factors, including our results of operations and the performance of our business, competitive conditions, general economic, political and social factors, the performance of the Indian and global economy and significant developments in India's fiscal regime, volatility in the Indian and global securities market, performance of our competitors, the Indian Capital Markets, changes in the estimates of our performance or recommendations by financial analysts and announcements by us or others regarding contracts, acquisitions, strategic partnerships, joint ventures, or capital commitments. In addition, if the stock markets experience a loss of investor confidence, the trading price of our Equity Shares could decline for reasons unrelated to our business, financial condition or operating results. The trading price of our Equity Shares might also decline in reaction to events that affect other companies in our industry even if these events do not directly affect us. Each of these factors, among others, could materially affect the price of our Equity Shares. There can be no assurance that an active trading market for our Equity Shares will develop or be sustained after this Issue, or that the price at which our Equity Shares are initially offered will correspond to the prices at which they will trade in the market subsequent to this Issue. For further details of the obligations and limitations of Market Makers, please refer to the section titled "**General Information – Details of the Market Making Arrangement for this Issue**" on page 37 of this Prospectus.

34. *There may be restrictions on daily movements in the price of our Equity Shares, which can adversely affect shareholder's ability to sell, or the price at which it can sell, Equity Shares at a particular point of time.*

Subsequent to listing, our Company may be subject to a daily circuit breaker imposed on listed companies by the BSE, which does not allow transactions having crossed certain volatility limit in the price of its Equity Shares. This circuit breaker operates independently of the index-based market-wide circuit breakers generally imposed by SEBI on Indian stock exchanges. The percentage limit on our Company's circuit breaker is set by the BSE based on certain factors such as the historical volatility in the price and trading volume of the Equity Shares. The BSE is not required to inform us of the percentage limit of the circuit breaker from time to time, and may change it without our knowledge. This circuit breaker, if imposed, would effectively limit the upward and downward movements in the price of the Equity Shares. As a result of this circuit breaker, we cannot assure that the shareholders will be able to sell the Equity Shares at desired prices.

C. External Risk Factors

35. *A slowdown in economic growth in India could cause our business to suffer.*

Our results of operations and financial condition are dependent on, and have been adversely affected by, conditions in financial markets in the global economy and, particularly in India. The Indian economy could be adversely affected by various factors such as political or regulatory action, including adverse changes in liberalization policies, business corruption, social disturbances, terrorist attacks and other acts of violence or war, natural calamities, interest rates, inflation, commodity and energy prices and various other factor Any slowdown in the Indian economy may adversely affect our business, financial condition, results of operations and the price of our Equity Shares.

36. *Regulatory changes with regard to Direct/Indirect taxes may adversely affect our performance or financial conditions.*

Regulatory changes relating to business segments in which we operate in India can have a bearing on our business. Each State in India has different local taxes and levies which may include value added tax, sales tax and octroi. Changes in these local taxes and levies may impact our profits and profitability. Any negative changes in the regulatory conditions in India or our other geographic markets could adversely affect our business operations or financial conditions.

37. *Instability of economic policies and the political situation in India or elsewhere could adversely affect the fortunes of the industry.*

There is no assurance that the liberalization policies of the government will continue in the future. Protests against privatization could slow down the pace of liberalization and deregulation. The Government of India plays an important role by regulating the policies governing the private sector over the past several years.

Unstable internal and international political environment could impact the economic performance in both the short term and the long term. The Government has traditionally exercised and continues to exercise a significant influence over many aspects of the Indian economy. Our Company's business, and the market price and liquidity of the Equity Shares, may be affected by changes in interest rates, changes in the Government policy, taxation, social and civil unrest and other political, economic or other developments in or affecting India.

38. Regional hostilities, terrorist attacks, communal disturbances, civil unrest and other acts of violence or war involving India and other countries may result in a loss of investor confidence and adversely affect the financial markets and our business.

Terrorist attacks, civil unrest and other acts of violence or war may negatively affect the Indian markets on which our Equity Shares will trade and also adversely affect the worldwide financial markets. In addition, the Asian region has from time to time experienced instances of civil unrest and hostilities among neighbouring countries. Hostilities and tensions may occur in the future and on a wider scale. Military activity or terrorist attacks in India, such as the attacks in Mumbai in November 2008 and in July 2011, may result in investor concern about stability in the region, which may adversely affect the price of our Equity Shares. Events of this nature in the future, as well as social and civil unrest within other countries in Asia, could influence the Indian economy and could have an adverse effect on the market for securities of Indian companies, including our Equity Shares.

39. The occurrence of natural disasters may adversely affect our business, financial condition and results of operations.

The occurrence of natural disasters, including hurricanes, floods, earthquakes, tornadoes, fires and pandemic disease may adversely affect our financial condition or results of operations. The potential impact of a natural disaster on our results of operations and financial position is speculative, and would depend on numerous factor The extent and severity of these natural disasters determines their effect on the Indian economy. Although the long term effect of diseases such as the H5N1 "avian flu" virus, or H1N1, the swine flu virus, cannot currently be predicted, previous occurrences of avian flu and swine flu had an adverse effect on the economies of those countries in which they were most prevalent. An outbreak of a communicable disease in India would adversely affect our business and financial conditions and results of operations. We cannot assure you that such events will not occur in the future or that our business, financial condition and results of operations will not be adversely affected.

40. Any downgrading of India's debt rating by a domestic or international rating agency could negatively impact our business.

Any adverse revisions to India's credit ratings for domestic and international debt by domestic or international rating agencies may adversely impact our ability to raise additional financing, and the interest rates and other commercial terms at which such additional financing is available. This could have an adverse effect on our financial results and business prospects, ability to obtain financing for capital expenditures and the price of our Equity Shares.

41. Our transition to IFRS reporting could have a material adverse effect on our reported results of operations or financial condition.

Our Company may be required to prepare annual and interim financial statements under IFRS in accordance with the roadmap for the adoption of, and convergence with, the IFRS announced by the Ministry of Corporate Affairs, Government of India through a press note dated January 22, 2010 ("IFRS Convergence Note"). The Ministry of Corporate Affairs by a press release dated February 25, 2011 has notified that 32 Indian Accounting Standards are to be converged with IFR The date of implementation of such converged Indian accounting standards has not yet been determined and will be notified by the Ministry of Corporate Affairs after various tax related issues are resolved. We have not yet determined with certainty what impact the adoption of IFRS will have on our financial reporting. Our financial condition, results of operations, cash flows or changes in the shareholders' equity may appear materially different under IFRS than under Indian GAAP or our adoption of IFRS may adversely affect our reported results of operations or financial condition. This may have a material adverse effect on the amount of income recognized during that period.

42. We have not independently verified certain data in this Prospectus.

We have not independently verified data from industry publications contained herein and although we believe these sources to be reliable, we cannot assure you that they are complete or reliable. Such data may also be produced on a different basis from comparable information compiled with regard to other countries. Therefore, discussions of matters

Bansal Roofing Products Limited

relating to India and its economy are subject to the caveat that the statistical and other data upon which such discussions are based have not been verified by us and may be incomplete or unreliable.

These facts and other statistics include the facts and statistics included in “*Summary of Industry*” and “*Industry Overview*” on pages 25 and 66, respectively. Due to possibly flawed or ineffective data collection methods or discrepancies between published information and market practice and other problems, the statistics herein may be inaccurate or may not be comparable to statistics produced elsewhere and should not be unduly relied upon. Further, we cannot assure you that they are stated or compiled on the same basis or with the same degree of accuracy, as the case may be, elsewhere.

43. Disruption in services of third party transport providers may affect our business operations

Our Company is dependent on third-party transport providers for the supply of raw materials to our factory and delivery of our products to our customers. Any increase in oil prices, may lead to increase in transportation costs will result in an impact on profitability. Further, transport strikes by member of various Transport unions have taken place in the past and could take place in future that will affect supplies of raw material and deliver our products to our customers, which may cause adverse impact on our business.

Prominent Notes

1. Initial public Issue of 6,80,000 Equity Shares of face value of ₹ 10 each of our Company for cash at a price of ₹ 30.00 per Equity Share (including a share premium of ₹ 20.00 per Equity Share) aggregating up to ₹ 204.00 Lakhs, of which 36,000 Equity Shares of face value of ₹ 10/- each at a price of ₹ 30/- per Equity Share aggregating to ₹ 10.80 Lakhs, will be reserved for subscription by Market Makers to the Issue (the “Market Maker Reservation Portion”) and Net Issue to the Public of 6,44,000 Equity Shares of ₹ 10/- each at a price of ₹ 30/- per Equity Share aggregating to ₹ 193.20 Lakhs (hereinafter referred to as the “Net Issue”). The Issue and the Net Issue will constitute 30.95% and 29.31% respectively, of the post issue paid up Equity Share capital of our Company.
2. This Issue is being made for at least 25% of the post- issue paid-up Equity Share capital of our Company, pursuant to Rule 19(2)(b)(i) of the Securities Contracts (Regulation) Rules, 1957 as amended. This Issue is being made in terms of Chapter XB of the SEBI (ICDR) Regulations, 2009, as amended from time to time. As per Regulation 43(4) of the SEBI (ICDR) Regulations, as amended, since our is a fixed price issue ‘the allocation’ is the net issue to the public category shall be made as follows:
 - a) Minimum fifty percent to retail individual investors; and
 - b) Remaining to other than retail individual investors; and
 - c) The unsubscribed portion in either of the categories specified in (a) or (b) above may be allocated to the applicants in the other category.
3. The Net worth of our Company as on December 31, 2013 and March 31, 2013 was ₹ 191.92 Lakhs and ₹ 161.12 Lakhs respectively. For more information, see the section titled “*Financial Statements*” beginning on page 133 of this Prospectus.
4. The NAV / Book Value per Equity Share, based on Restated Financials of our Company as on December 31, 2013 and March 31, 2013 was ₹ 19.19 and ₹ 16.11 respectively. For more information, see the section titled “*Financial Information of the Company*” beginning on page 113 of this Prospectus.
5. The average cost of acquisition of Equity Shares by our Promoters is set out below:-

Name of our Promoters	Number of Equity Shares Held	Average Cost of Acquisitions (₹ per share)
Mr. Kaushalkumar S. Gupta	9,56,900	10.10
Mrs. Sangeeta K. Gupta	3,64,000	0.77

As certified by our Statutory Auditor vide their certificate dated May 21, 2014.

For Further details, please refer to “*Capital Structure*” on page 39 of this Prospectus.

Bansal Roofing Products Limited

6. The details of transactions of our Company with related parties, nature of transactions and the cumulative value of transactions during 9 months period ended December 31, 2013 and last financial year ended March 31, 2013 are as follows:

(in ₹)

Nature of Transaction	Transaction Amount during 9 months period ended December 31, 2013	Transaction Amount for last Financial Year ended March 31, 2013
Remuneration	12,25,000.00	7,20,000.00
Salary	1,00,000.00	0.00
Rent	1,35,000	0.00
Equity Contribution	0.00	90,00,000.00
Finance	65,00,000.00	0.00
Purchase of Fixed Assets	40,215.00	5,000.00
Services rendered	55,935.00	0.00
Services Received	1,22,156.00	1,22,956.00
Purchase	43,212.00	1,09,593.00
Sale	3,61,17,088.00	13,89,99,313.00

For more details on the related party transactions, please refer to section titled “**Financial Statements - Annexure N - Statement of Related Parties Transactions,**” on page no. 134.

7. No Group entities have any business or other interest in our Company, except as stated in section titled “**Financial Information of the Company and Annexure N - Statement of Related Parties Transactions, as Restated**” on page 113 and 134 respectively, and “**Our Promoter Group & Promoter Group Entities**” on page 108, and to the extent of any Equity Shares held by them and to the extent of the benefits arising out of such shareholding.
8. Our Company was originally incorporated on May 01, 2008, as “Bansal Roofing Private Limited” under the provisions of the Companies Act, 1956 with the Registrar of Companies, Gujarat, Dadra & Nagar Havelli. Pursuant to Shareholders Resolution passed at the Extra Ordinary General Meeting of the Company held on August 24, 2013 name of our Company was changed to “Bansal Roofing Products Private Limited” from “Bansal Roofing Private Limited” and a fresh Certificate of Incorporation dated August 29, 2013 was issued by the Registrar of Companies, Gujarat, Dadra & Nagar Havelli,. Subsequently, our Company was converted into a public limited company pursuant to Shareholders Resolution passed at the Extra Ordinary General Meeting of the Company held on November 1, 2013 and the name of our Company was changed to “Bansal Roofing Products Limited” pursuant to a fresh Certificate of Incorporation dated November 19, 2013 issued by the Registrar of Companies, Gujarat, Dadra & Nagar Havelli. For details of the changes in our Name and Registered Office, please see section titled “**History and Certain Corporate Matters**” on page 90 of this Prospectus.
9. None of our Promoters, Promoter Group, Directors and their relatives has entered into any financing arrangement or financed the purchase of the Equity Shares of our Company by any other person during the period of six months immediately preceding the date of filing of Prospectus.
10. Our Company, Promoters, Directors, Promoter Group, Group entities have not been prohibited from accessing the Capital Market under any order or direction passed by SEBI nor they have been declared as willful defaulters by RBI / Government authorities. Further, no violations of securities laws have been committed by them in the past or pending against them.
11. Investors are advised to see the paragraph titled “**Basis for Issue Price**” beginning on page 55 of this Prospectus.
12. The Lead Manager and our Company shall update this Prospectus / Prospectus and keep the investors / public informed of any material changes till listing of the Equity Shares offered in terms of this Prospectus and commencement of trading.
13. Investors are free to contact the Lead Manager i.e. Hem Securities Limited for any clarification, complaint or information pertaining to the Issue. The Lead Manager and our Company shall make all information available to the public and investors at large and no selective or additional information would be made available for a section of the investors in any manner whatsoever.

14. In the event of over-subscription, allotment shall be made as set out in paragraph titled “***Basis of Allotment***” beginning on page 193 of this Prospectus and shall be made in consultation with the Designated Stock Exchange i.e. BSE. The Registrar to the Issue shall be responsible to ensure that the basis of allotment is finalized in a fair and proper manner as set out therein.
15. The Directors / Promoters of our Company have no interest in our Company except to the extent of remuneration and reimbursement of expenses (if applicable) and to the extent of any Equity Shares of our Company held by them or their relatives and associates or held by the companies, firms and trusts in which they are interested as director, member, partner, and/or trustee, and to the extent of benefits arising out of and to the extent of interests as disclosed under the chapter titled “***Our Management***” beginning at page 93 chapter titled “***Our Promoter Group & Promoter Group Entities***” beginning at page 108 and chapter titled “***Financial Information of the Company***” beginning at page 113 of this Prospectus.
16. No loans and advances have been made to any person(s) / companies in which Directors are interested except as stated in the Auditors Report. For details, please see “***Financial Information of the Company***” beginning on page 113 of this Prospectus.

SECTION III: INTRODUCTION

SUMMARY OF OUR INDUSTRY

This is only a summary and does not contain all the information that you should consider before investing in our Equity Shares. You should read the entire Prospectus, including the information contained in the sections titled “Risk Factors” and “Financial Information of the Company” and related notes beginning on page 10 and 114 respectively of the Prospectus before deciding to invest in our Equity Shares.

India with a GDP of US\$ 1.758 trillion (2013 estimated), is, according to the CIA Factbook, the world's 4th largest economy in Purchasing Power Parity (PPP) terms (the GDP for 2013 in PPP terms is estimated at approximately US\$4.962trillion). Per-capita GDP, in turn, is estimated at US\$4,000 in 2013 in PPP terms. India is now one of the fastest growing economies in the world. According to the CIA Factbook, India's real GDP growth rate was 4.70% in 2013(est.) (Source: Central Intelligence Agency, World Factbook - India, updated on May 9, 2014)

Steel Industry

Introduction

Steel is one of the most widely used metals in the world. It forms a key constituent of all major economies. Accordingly, the growth in steel consumption is a function of the growth pattern of its various end-use sectors viz. manufacturing, infrastructure, automobile, housing etc. which ultimately guide the country's economy.

India has become the second best in terms of growth amongst the top ten steel producing countries in the world and a net exporter of steel during 2013–14. Steel production in India recorded a growth rate of 4.8 per cent in February 2014 over February 2013. The cumulative growth during April–February, 2013–14 stood at 4.2 per cent over the corresponding period of the previous year. Steel contributes to nearly two per cent of the gross domestic product (GDP) and employs over 500,000 people. The total market value of the Indian steel sector stood at US\$ 57.8 billion in 2011 and is expected to touch US\$ 95.3 billion by 2016. The infrastructure sector is India's largest steel consumer, thereby attracting investments from several global players. Owing to this connection with core infrastructure segments of the economy, the steel industry is of high priority right now. Also, steel demand is derived from other sectors like automobiles, consumer durables and infrastructure; therefore, its fortune is dependent on the growth of these user industries.

(Source: <http://www.ibef.org/industry/steel.aspx> last visited on May 23, 2014)

The liberalisation of the industrial policy and other government initiatives have given a definite impetus for entry, participation and growth of the private sector in the steel industry. Allowing foreign direct investment (FDI) has been a positive step since India is heavily dependent on foreign technologies. These foreign technologies generally add life to the plant and production units, which ultimately lead to the country's economic growth.

(Source: <http://www.ibef.org/industry/steel.aspx> last visited on May 23, 2014)

Types of Steel

Steel is an iron based mixture containing two or more metallic and/or non metallic elements usually dissolving into each other when molten. Since it is an iron based alloy—as per its end use requirements—other than iron it may contain one or more other elements such as carbon, manganese, silicon, nickel, lead, copper, chromium, etc. For example, stainless steel (a type of steel) mainly contains chromium that is normally more than 10.5 percent with/without nickel or other alloying elements. Steel is produced using Steel Melting Shop that includes converter, open hearth furnace, electric arc furnace and electric induction furnace. There are broadly two types of steel according to its composition: alloy steel and non-alloy steel. Alloying steel is produced using alloying elements like manganese, silicon, nickel, chromium, etc. Non-alloy steel has no alloying component in it except that are normally present such as carbon. Non-alloy steel is mainly of three types viz. mild steel (contains upto 0.3% carbon), medium steel (contains between 0.3-0.6% carbon) and high steel (contains more than 0.6% carbon). All types of steel other than mild steel are called special steel. It is mainly because a special care is taken in order to maintain particular level of chemical composition in such steel. This process gives different properties to the steel according to its composition. In India, non-alloying steel constitutes about 95 percent of total finished steel production, and mild steel has large share in it.

According to shape/size/form steel is categorized into different types such as liquid steel, ingots, semis (semi-finished steel) and finished steel. Liquid steel is a first product that comes out from Steel Melting Shop. Liquid steel further goes into ingots, and then ingots advance to semis. Semis are called semi-finished steel products because they are further subject to forging/rolling in order to produce finish steel products such as flat steel products and long steel products. Crude steel

Bansal Roofing Products Limited

generally includes ingots and semis. According to end use, steel is categorized into structural steels, construction steel, deep drawing Steel, forging quality, rail steel, etc. The following chart depicts various types of steel products according to different categories.

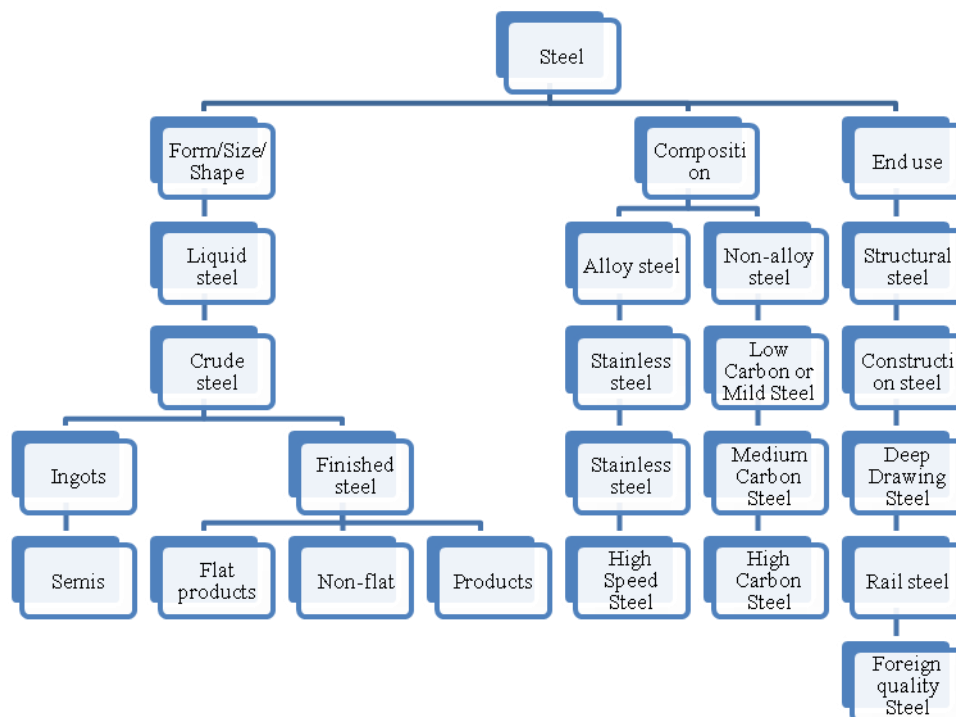

Market Size

(Source: <http://www.ibef.org/industry/steel.aspx> last visited on May 23, 2014)

India's real consumption of total finished steel grew by 0.6 per cent year-on-year in April–March 2013-14 to 73.93 million tonnes (MT), according to Joint Plant Committee (JPC), Ministry of Steel. Construction sector accounts for around 60 per cent of the country's total steel demand while the automobile industry consumes 15 per cent.

India became net steel exporter in 2013–14 and is likely to maintain the momentum in 2014-15 as producers are looking to dock more overseas shipment to tide over subdued domestic consumption. Total steel exports by India during 2013–14 stood at 5.59 MT, as against imports of 5.44 MT. During the period, Steel Authority of India (SAIL) clocked a 30 per cent growth in exports and aims to more than double the shipments to 1 MT in 2014–15. Rashtriya Ispat Nigam Ltd (RINL), which exported 1 lakh tonne steel last fiscal, aims to treble that in the current fiscal.

Iron ore export from India has showed a 253 per cent increase during the period October–December 2013, at 3.75 MT as against 1.06 MT in the corresponding period of the previous year, on the back of the opening of new mines in Chhattisgarh, Madhya Pradesh and Rajasthan, as per the Federation of Indian Mineral Industries (FIMI).

SUMMARY OF OUR BUSINESS

We are mainly a manufacturer of roofing sheets and roofing accessories such as Colour Coated Roof Sheets, FRP Roof Sheets, Polycarbonate Sheets. We also manufacture Eco Ventilators and other miscellaneous Roofing Accessories and provide all roofing solutions our valuable customers, under one roof. We believe that we have built domain expertise in roofing solutions in a short span which has contributed in our business growth. Promoters of our Company have been associated with roofing industry since more than a decade.

Our Company was incorporated in 2008, with foraying into business of marketing of roofing sheets and started trading of the same afterwards. We have started our commercial production in the year 2012, since than our continued rapid growth is a testament to the certainty, our Customers experience every day.

Registered office of our Company is at 3/2, Labdhi Industrial Estate, Acid Mill Compound, Ranmukteshwar Road, Pratapnagar, Vadodara, 390004, Gujarat, India.

Our manufacturing facility is situated at Plot No. 06, Raj Industrial Estate, Vadadala, Near Samlatya Crossing, Vadodara, 391520, Gujarat. The products manufactured by our Company are made on automatic and semi automatic Roll forming machine, Crimping Machine, Shearing Machine and folding machine.

Our Company's Total Income and Restated Profit after Tax for the year ended March 31, 2013 was ₹ 1715.51 Lacs and ₹ 64.14 Lacs respectively. For the 9 months period ended on December 31, 2013, our Company's Total Income and Restated Profit after Tax was ₹ 1411.58 Lacs and ₹ 30.80 Lacs, respectively.

OUR COMPETITIVE STRENGTH

We believe that the following are our primary competitive strength:

1. Experienced Management Team

We benefit from the leadership of our management team, which has extensive experience in roofing industry. Our Promoters have more than adequate experience in roofing industry and we have successfully grown under their efficient leadership in the past. Our Promoters are actively involved in our operations and bring to our Company their vision and leadership which we believe has been instrumental in sustaining our business operations. Our Company feels that the strength of any successful organization lies in the experience and guidance of its team leaders and staff alike. Our key managerial personnel are largely responsible for successful execution our growth strategy by developing new customer base and strengthening our customer relationships.

2. Strong Range of Products, Strong Brand Image

Over the years we have strengthened our products portfolio in order to address the varied and expanding requirement of our customers. Our products portfolio include Colour Coated Roof Sheets, FRP Roof Sheets, Polycarbonate Sheets, Turbo Ventilators and other miscellaneous Roofing Accessories. We believe that our product portfolio allow our customers to source all products under one roof to fulfil their roofing requirements, which helps us to expand our business from existing customers as well as address potential new customers. We believe our products portfolio provide our customers one stop solution for their roofing requirements

Over the years we have successfully developed a strong and reliable brand image for our Company, which provides us a competitive edge over other competitor.

3. Quality Assurance and Standards

We believe in providing our customers the best possible quality. All products that leave the factory premise goes through stringent quality check. Also, quality check is done at every stage of manufacturing to ensure the adherence to desired specifications. Since, our Company is dedicated towards quality of products, processes and inputs; we get repetitive orders from our buyers, as we are capable of meeting their quality standards.

4. Extensive and Cost beneficial Manufacturing Facility

Our manufacturing facility has all good facility. We believe that this enables us to control costs and increase our profit margins and gives us a competitive advantage over some of our competitors who do not have their own

manufacturing facilities. We believe that our large skilled workforce with knowledge and expertise in roofing industry is a key competitive strength that has enabled us to establish and maintain our reputation and brand.

OUR BUSINESS STRATEGY

1. Increasing our geographical reach

Roofing markets have shown increased growth with many projects coming up in real estates, infrastructural developments. With thrust in the development of core infrastructure we believe there are ample opportunities available for us to cater to the ever expanding requirement. Accordingly we promote our products in India as well as in African markets through our marketing managers and executives, who help in understanding client requirements and oversee execution into desired products.

2. Focus on Cordial relations with our Suppliers, Customers and employees

We believe in developing and maintaining long term sustainable relationships with our suppliers, consumers and employees which will help us in achieving the goals set, particularly in view of entering in to new markets. We offer wide range of products at competitive prices, which will help us achieve consumer satisfaction and build long term relationships, which will translate into repeated sales.

3. To build-up a professional organization

As an organization we believe in transparency and commitment in our work among our work force and with our suppliers, customers, government authorities, banks, financial institutions etc. We have employed experienced persons for taking care of our day to day activities. We also consult with outside agencies on a case to case basis on technical and financial aspects of our business. Hence, the philosophy of professionalism is foundation stone of our business strategy and we wish to make it more sound and strong in times to come.

MARKETING STRATEGY

Our Company is based in Gujarat. We use print media advertisements, pamphlets for local area distribution, Newspaper advertisements in local publications with a view to create a visibility. Further, the Company has planned a marketing strategy Audio Promotion via radio channels, Print Promotion- Newspaper Ads, Posters, Online Promotion through Internet; and Freebies like Vouchers. Our Marketing Manager and export manager has also extensively marketed our product in African country which will help us in increasing our production.

SUMMARY OF OUR FINANCIALS

ANNEXURE - I

RESTATED STATEMENT OF ASSETS AND LIABILITIES

(Amt in ₹)

Particulars	As at					
	31-12-13	31-03-13	31-03-12	31-03-11	31-03-10	31-03-09
I. EQUITY AND LIABILITIES						
Shareholder's Funds						
Share Capital	10000000.00	10000000.00	1000000.00	100000.00	100000.00	100000.00
Reserves and Surplus	9191897.40	6112017.47	(301930.32)	285260.75	214001.79	126830.08
Non Current Liabilities						
Long-term Borrowings	8317392.67	14414860.97	14200000.00	700000.00	0.00	0.00
Deferred Tax Liabilities (Net)	758826.88	506459.89	82244.14	8038.98	6162.65	3696.83
Long-term Provisions	0.00	0.00	0.00	0.00	0.00	0.00
Current Liabilities						
Short-term Borrowings	6050931.85	3396113.00	0.00	0.00	0.00	80000.00
Trade Payables	15496812.10	22989766.65	5956995.15	102562.00	139131.00	195027.87
Other Current Liabilities	5514446.00	699915.00	54729.00	36515.00	53019.00	0.00
Short-term Provisions	1556334.00	2306467.00	37877.00	32916.00	36515.00	53019.00
Total	56886640.90	60425599.98	21029914.97	1265292.73	548829.44	558573.78
II. Assets						
Non Current Assets						
Fixed assets	16471172.19	14770950.44	13785868.35	87275.10	92013.23	96751.35
Non Current Investments	0.00	0.00	0.00	0.00	0.00	0.00
Long-term Loans and Advances	43944.00	41544.00	41544.00	0.00	0.00	0.00
Other Non Current Assets	0.00	0.00	0.00	0.00	0.00	0.00
Current assets						
Current Investments	0.00	0.00	0.00	0.00	0.00	0.00
Inventories	23755895.06	22228963.84	4244096.00	0.00	0.00	0.00
Trade Receivables	3047743.00	19580877.00	744902.00	349073.90	264170.90	277808.90
Cash and Cash Equivalents	3861541.26	460891.78	564484.81	712517.56	99236.31	157379.53
Short-term Loans and Advances	4617619.98	155370.63	338938.00	0.00	0.00	0.00
Other Current Assets	5088725.41	3187002.29	1310081.81	116426.17	93409.00	26634.00
Total	56886640.90	60425599.98	21029914.97	1265292.73	548829.44	558573.78
Note: The above statement should be read with the significant accounting policies and notes to restated summary statements, restated statement of profit and loss and restated cash flow statement as appearing in Annexures IV, II and III.						

ANNEXURE - II

RESTATED STATEMENT OF PROFIT AND LOSS

(Amt. in ₹)

Particulars	For 9 months period ended	For the Year ended				
	31-12-13	31-03-13	31-03-12	31-03-11	31-03-10	31-03-09
Revenue from Operations	141157650.29	171550783.37	7084759.11	672794.80	448638.00	458816.40
Other income	6562.00	0.00	0.00	0.00	1583.25	0.00
Total Revenue	141164212.29	171550783.37	7084759.11	672794.80	450221.25	458816.40
Expenses:						
Cost of Sales	129301526.15	175038417.78	10579194.81	83900.50	127631.00	123256.62
Changes in inventories of finished goods, WIP and Stock-in-Trade	(1526931.22)	(17984867.84)	(4244096.00)	0.00	0.00	0.00
Employee benefits expense	3073796.00	2180191.00	540912.00	354619.75	165000.00	120000.00
Finance costs	744835.06	192440.97	9273.75	275.75	0.00	1988.77
Depreciation and amortization expense	467433.55	510489.31	72263.80	4738.13	4738.13	2998.65
Preliminary Expenses written off	0.00	0.00	0.00	10000.00	10000.00	10000.00
Other expenses	4271305.83	2667938.61	640196.66	106664.38	16699.60	17026.45
Total Expenses	136331965.37	162604609.83	7597745.02	560198.51	324068.73	275270.49
Profit before exceptional and extraordinary items and tax (A-B)	4832246.92	8946173.54	(512985.91)	112596.30	126152.53	183545.91
Exceptional item	0.00	0.00	0.00		0.00	0.00
Profit before extraordinary items and tax	4832246.92	8946173.54	(512985.91)	112596.30	126152.53	183545.91
Extraordinary item	0.00	0.00	0.00	0.00	0.00	0.00
Profit Before Tax	4832246.92	8946173.54	(512985.91)	112596.30	126152.53	183545.91
Provision for Tax						
- Current Tax	1500000.00	2108010.00	0.00	32916.00	36515.00	53019.00
- Fringe Benefit Tax	0.00	0.00	0.00	0.00	0.00	0.00
- Tax adjustment of prior years	0.00	0.00	0.00	6545.00	0.00	0.00
- Deferred Tax Liability / (Asset)	252366.99	424215.75	74205.15	1876.33	2465.82	3696.83
Restated profit after tax from continuing operations	3079879.93	6413947.79	(587191.06)	71258.96	87171.71	126830.08
Discontinuing operation						
Restated profit for the year	3079879.93	6413947.79	(587191.06)	71258.96	87171.71	126830.08
Balance brought forward from previous year	6112017.47	(301930.32)	285260.75	214001.79	126830.08	0.00
Accumulated Profit/ (Loss) carried to Balance Sheet	9191897.40	6112017.47	(301930.32)	285260.75	214001.79	126830.08

Note: The above statement should be read with the significant accounting policies and notes to restated summary statements, restated statement of assets and liabilities and restated cash flow statement as appearing in Annexures IV, I and III.

ANNEXURE - III

RESTATED CASH FLOW STATEMENT

(Amt. in ₹)

Particulars	For 9 months period ended	For the Year ended				
	31-12-13	31-03-13	31-03-12	31-03-11	31-03-10	31-03-09
1. Cash Flow From Operating Activities:						
Net Profit after taxes	3079879.93	6413947.79	(587191.06)	71258.96	87171.71	126830.08
<i>Adjustments for:</i>						
Depreciation and amortization expense	467433.55	510489.31	72263.80	4738.13	4738.13	2998.65
Interest and Finance Cost	744835.06	192440.97	9273.75	275.75	0.00	1988.77
Current Income Tax	1500000.00	2108010.00	0.00	32916.00	36515.00	53019.00
Tax Adjustment of Previous year	0.00	0.00	0.00	6545.00	0.00	0.00
Deferred Tax	252366.99	424215.75	74205.15	1876.33	2465.82	3696.83
Preliminary Expenses	0.00	0.00	0.00	10000.00	10000.00	10000.00
Operating Profit before Working Capital Changes	6044515.53	9649103.82	(431448.36)	127610.17	140890.65	198533.33
<i>Adjustments for:</i>						
Changes in Inventories	(1526931.22)	(17984867.84)	(4244096.00)	0.00	0.00	0.00
Changes in Trade Receivables	16533134.00	(18835975.00)	(395828.10)	(84903.00)	13638.00	(277808.90)
Changes in other current assets	766786.88	(376920.48)	(995375.64)	(46937.17)	(24355.00)	(6634.00)
Changes in Trade Payables	(7492954.55)	17032771.50	5854433.15	(36569.00)	(55896.87)	195027.87
Changes in other Current Liabilities & Short-term Provisions	2564398.00	805766.00	56091.00	0.00	0.00	0.00
Cash Generated from Operation	16888948.64	(9710122.00)	(156223.95)	(40799.00)	74276.78	109118.30
Taxes Paid	2668510.00	1500000.00	231196.00	45644.00	52420.00	0.00
Net Cash from Operating Activities	14220438.64	(11210122.00)	(387419.95)	(86443.00)	21856.78	109118.30
2. Cash Flow From Investing Activities:						
Fixed Assets Purchased	(2167655.30)	(1495571.40)	(13770857.05)	0.00	0.00	(99750.00)
Interest Received	0.00	0.00	0.00	0.00	0.00	0.00
Long/Short Term Loans and Advance	(4464649.35)	183567.37	(380482.00)	0.00	0.00	0.00
Long Term Current Liabilities	0.00	0.00	0.00	0.00	0.00	0.00
Net Cash from Investing Activities	(6632304.65)	(1312004.03)	(14151339.05)	0.00	0.00	(99750.00)
3. Cash Flow From Financing Activities:						
Proceeds from issue of shares	0.00	9000000.00	900000.00	0.00	0.00	100000.00
Proceeds from Short term borrowings	2654818.85	3396113.00	0.00	0.00	(80000.00)	80000.00
Proceeds from Long term borrowings	(6097468.30)	214860.97	13500000.00	700000.00	0.00	0.00
Expenses towards	0.00	0.00	0.00	0.00	0.00	(30000.00)

Bansal Roofing Products Limited

incorporation of Company						
Interest paid	(744835.06)	(192440.97)	(9273.75)	(275.75)	0.00	(1988.77)
Net Cash from Financing Activities	(4187484.51)	12418533.00	14390726.25	699724.25	(80000.00)	148011.23
Net Increase/ (Decrease) in Cash & Cash Equivalents	3400649.48	(103593.03)	(148032.75)	613281.25	(58143.22)	157379.53
Cash & Cash Equivalents at the beginning of the year	460891.78	564484.81	712517.56	99236.31	157379.53	0.00
Cash & Cash Equivalents at the end of the year	3861541.26	460891.78	564484.81	712517.56	99236.31	157379.53

Note:

1. The Cash Flow Statement has been prepared under the 'Indirect Method' as set out in Accounting Standard - 3 on Cash Flow Statements as recommended by Companies Accounting Standard Rules, 2006.
2. Figures in Brackets represents outflow.
3. The above statement should be read with the significant accounting policies and notes to restated summary statements, restated statement of assets and liabilities and restated statement of profit and loss as appearing in Annexures IV, I and II.

THE ISSUE

PRESENT ISSUE IN TERMS OF THIS PROSPECTUS	
Equity Shares Offered: Present Issue of Equity Shares by our Company	6,80,000 Equity Shares having Face Value of ₹ 10.00 each for cash at a price of ₹ 30.00 per share aggregating to ₹ 204.00 Lakhs
Issue Reserved for the Market Makers	36,000 Equity Shares of ₹ 10.00 each for cash at a price of ₹ 30.00 per share aggregating ₹ 10.80 Lakhs
Net Issue to the Public*	6,44,000 Equity Shares of ₹ 10.00 each for cash at a price of ₹ 30.00 per share aggregating ₹ 193.20 Lakhs
	of which
	3,22,000 Equity Shares of ₹ 10.00 each at a premium of ₹ 20.00 per Equity Share will be available for allocation for allotment to Retail Individual Investors of up to ₹ 2.00 Lakhs
	3,22,000 Equity Shares of ₹ 10.00 each at a premium of ₹ 20.00 per Equity Share will be available for allocation for allotment to Other than Retail Individual Investors of above ₹ 2.00 Lakhs
Equity Shares outstanding prior to the Issue	15,17,200 Equity Shares of face value of ₹ 10.00 each
Equity Shares outstanding after the Issue	21,97,200 Equity Shares of face value of ₹ 10.00 each
Objects of the Issue	Please see the chapter titled “ <i>Objects of the Issue</i> ” on page 49 of this Prospectus

This Issue is being made in terms of Chapter XB of the SEBI (ICDR) Regulations, 2009, as amended from time to time for at least 25% of the post- issue paid-up Equity Share capital of our Company, pursuant to Rule 19(2)(b)(i) of the Securities Contracts (Regulation) Rules, 1957 as amended.

For further details please refer to “*Issue Structure*” on page 178 of this Prospectus.

*As per Regulation 43(4) of the SEBI (ICDR) Regulations, as amended, as present issue is a fixed price issue ‘the allocation’ is the net offer to the public category shall be made as follows:

- a) Minimum fifty percent to retail individual investors; and
- b) Remaining to Other than Retail Individual Investors

The unsubscribed portion in either of the categories specified in (a) or (b) above may be allocated to the applicants in the other category.

If the retail individual investor category is entitled to more than fifty per cent on proportionate basis, accordingly the retail individual investors shall be allocated that higher percentage.

GENERAL INFORMATION

Our Company was originally incorporated on May 01, 2008, as “Bansal Roofing Private Limited” under the provisions of the Companies Act, 1956 with the Registrar of Companies, Gujarat, Dadra & Nagar Havelli. Pursuant to Shareholders Resolution passed at the Extra Ordinary General Meeting of the Company held on August 24, 2013, name of our Company was changed to “Bansal Roofing Products Private Limited” from “Bansal Roofing Private Limited” and a fresh Certificate of Incorporation dated August 29, 2013 was issued by the Registrar of Companies, Gujarat, Dadra & Nagar Havelli,. Subsequently, our Company was converted into a public limited company pursuant to Shareholders Resolution passed at the Extra Ordinary General Meeting of the Company held on November 1, 2013 and the name of our Company was changed to “Bansal Roofing Products Limited” pursuant to a fresh Certificate of Incorporation dated November 19, 2013 issued by the Registrar of Companies, Gujarat, Dadra & Nagar Havelli.

Brief Company and Issue Information

Registered Office	3/2, Labdhi Industrial Estate, Acid Mill Compound, Ranmukteshwar Road, Pratapnagar, Vadodara, 390004, Gujarat, India Tel. No. +91-265-2580178, Fax No. +91-265-2581365 E-mail: cs@bansalroofing.com Website: www.bansalroofing.com
Factory Address	Plot No. 06, Raj Industrial Estate, Vadadala, Near Samlatya Crossing, Vadodara, 391520, Gujarat.
Date of Incorporation	May 01, 2008
Corporate Identification No.	U25206GJ2008PLC053761
Address of Registrar of Companies	Registrar of Companies, Gujarat, Dadra And Nagar Havelli, Roc Bhavan, Opposite Rupal Park Society, Behind Ankur Bus Stop, Naranpura, Ahmedabad – 380013 Phone: +91-79-27437597, Fax:+91-79-27438371 Email: roc.ahmedabad@mca.gov.in
Designated Stock Exchange	SME Platform of BSE Limited P.J. Tower, Dalal Street, Mumbai - 400001, Maharashtra
Issue Programme	Issue Opens on : Thursday, June 26, 2014 Issue Closes on : Monday, June 30, 2014
Company Secretary & Compliance Officer	Ms. Harnetkaur S. Anand Bansal Roofing Products Limited 3/2, Labdhi Industrial Estate, Acid Mill Compound, Ranmukteshwar Road, Pratapnagar, Vadodara – 390004, Gujarat, India Tel. No. +91-265-2580178, Fax No. +91-265-2581365 E-mail: cs@bansalroofing.com Website: www.bansalroofing.com

Note: Investors can contact the Compliance Officer or the Registrar to the Issue in case of any pre or post- Issue related problems, such as non-receipt of letters of allotment, credit of allotted shares in the respective beneficiary account and refund orders.

All grievances relating to the ASBA process may be addressed to the Registrar to the Issue with a copy to the SCSBs, giving full details such as name, address of applicant, application number, number of Equity Shares applied for, amount paid on application and designated branch or the collection centre of the SCSB where the ASBA Application Form was submitted by the ASBA Applicants.

For all issue related queries, and for redressal of complaints, Applicants may also write to the Lead Manager. All complaints, queries or comments received by Stock Exchange / SEBI shall be forwarded to the Lead Manager, who shall respond to the same.

Board of Directors of our Company

Our Board of Directors of our Company consists of:

Bansal Roofing Products Limited

Name	Designation	Address	DIN
Mr. Kaushalkumar S. Gupta	Chairman and Managing Director	C- 45, Shreedharpark Society, Opposite Novino Batteries, Makarpura Road, Vadodara, 390010, Gujarat, India	02140767
Mr. Satishkumar S. Gupta	Whole-time Director	B-46, Girdharpark, Makarpura, Vadodara, 390010, Gujarat, India	02140734
Mrs. Sangeeta K. Gupta	Whole-time Director	C- 45, Shreedharpark Society, Opposite Novino Batteries, Makarpura Road, Vadodara, 390010, Gujarat, India	02140757
Ms. Bhavitaben D. Gurjar	Non Executive Independent Director	C- 43, Shreedhar Park., Behind Makarpura Depo., Vadodara, 390010, Gujarat, India	06720448
Mrs. Beena P. Bisht	Non Executive Independent Director	A/8, Purusarth Bunglows, Off. 30 Meter, Ring Road, Opposite Ratnakar Tenament, Gotri, Vadodara, 390021, Gujarat, India	06696882
Mrs. Shilpaba A. Jadeja	Non Executive Independent Director	C-7, Anant Park, Near Sabri Vidyalaya, Saiyed Vasna Road, Vadodara, 390015, Gujarat, India	06696913

For further details of the Directors of our Company, please refer to the chapter titled “**Our Management**” on page 93 of this Prospectus.

Details of Key Intermediaries pertaining to this Issue and our Company:

Lead Manager of the Issue HEM SECURITIES LIMITED 14/15, Khatau Building, 1 st Floor, 40, Bank Street, Fort, Mumbai - 400 001 Tel. No.: 91-22 – 2267 1543 / 44 Fax No.: 91-22 – 2262 5991 Website: www.hemonline.com Email: ib@hemonline.com Investor Grievance Email: redressal@hemonline.com Contact Person: Mr. Mohit Baser SEBI Regn. No. INM000010981	Legal Advisor to the Issue MINDSPRIGHT LEGAL Office No.9, 3rd Floor, 7/10, Botawala Building, Hornimam Circle, Fort, Mumbai – 400 001 Tel. No.: +91 - 22 - 4002 0665 Fax No.: +91 – 22 - 4002 0664 Email: legal@mindspright.com Website: www.mindspright.com Contact Person: Mr. Amit Dey
Registrar to the Issue SHAREX DYNAMIC (INDIA) PRIVATE LIMITED Unit-1, Luthra Industrial Premises, 1st Floor, 44 – E, M Vasanti Marg, Andheri - Kurla Road, Safed Pool, Andheri (East), Mumbai – 400 072 Tel. No.: +91-22 – 2851 5606 / 44 Fax No.: +91-22 – 2851 2885 Website: www.sharexindia.com mail: info@sharexindia.com Contact Person: Mr. K. C. Ajitkumar SEBI Regn. No. INR000002102	Bankers to the Company STATE BANK OF INDIA 1 st Floor, Prime Complex, Opposite Shreyash School, Manjalpur, Vadodara, – 390011, Gujarat, India Tel No:+91-265– 2630653 Fax No:+91-265– 267271 Web:www.sbi.co.in Email: sbi.60387@sbi.co.in Contact Person: Mr. Brijendra Kumar Sharma
Statutory Auditors of the Company M/S. SANTLAL PATEL & CO. CHARTERED ACCOUNTANTS Address: 432, Phoniex Complex, Near Suraj Plaza, Sayajigunj, Vadodara, Gujarat, India Tel. No: +91- 265-2363343 Email: santlalpatel@rediffmail.com Contact Person: CA. Santlal C. Patel	Peer Review Auditors M/S. V. J. AMIN & CO. CHARTERED ACCOUNTANTS 204 – B, Silver Plaza, Opp. Rajvee Tower, Old Padra Road, Vadodara – 390 020, Gujarat, India Tel. No: +91-265-232106 Email: yvd_vipul@yahoo.com Contact Person: CA. Vipul M. Dalal
Bankers to the Issue (Escrow Collection Bank) HDFC BANK LIMITED GIG-OPS Department, Lodha-I, Think Techno Campus, 0-3 Level, Next to Kanjur Marg Railway Station, Kanjur Marg (East), Mumbai - 400 042 Tel: +91-22-30752928, Fax: +91-22-25799801 Email: uday.dixit@hdfcbank.com Website: www.hdfcbank.com Contact Person: Mr. Uday Dixit SEBI Regn: INBI00000063	Refund Banker to the Issue HDFC BANK LIMITED GIG-OPS Department, Lodha-I, Think Techno Campus, 0-3 Level, Next to Kanjur Marg Railway Station, Kanjur Marg (East), Mumbai - 400 042 Tel: +91-22-30752928, Fax: +91-22-25799801 Email: uday.dixit@hdfcbank.com Website: www.hdfcbank.com Contact Person: Mr. Uday Dixit SEBI Regn: INBI00000063

Statement of Inter se allocation of responsibilities

Since Hem Securities Limited is the sole Lead Manager to this Issue, a statement of inter se allocation of responsibilities among Lead Managers is not required.

Self Certified Syndicate Banks (“SCSBs”)

The list of Designated Branches that have been notified by SEBI to act as SCSB for the ASBA process is provided on www.sebi.gov.in/pmd/scsb.pdf For more information on the Designated Branches collecting ASBA Forms, see the above mentioned SEBI link.

Credit Rating

This being an Issue of Equity Shares, credit rating is not required.

IPO Grading

Since the issue is being made in terms of Chapter XB of the SEBI (ICDR) Regulations, there is no requirement of appointing an IPO Grading agency.

Debenture Trustees

As the Issue is of Equity Shares, the appointment of Debenture trustees is not required.

Monitoring Agency

As per Regulation 16(1) of the SEBI (ICDR) Regulations, 2009 the requirement of Monitoring Agency is not mandatory if the Issue size is below ₹ 500.00 crores.

However, as per the Clause 52 of the SME Listing Agreement to be entered into with the Stock Exchange upon listing of the Equity Shares and the Corporate Governance Requirements, the Audit Committee of our Company, would be monitoring the utilization of the proceeds of the Issue.

Experts Opinion

Except for the reports in the section “*Financial Information of the Company*” and “*Statement of Tax Benefits*” on page 113 and page 57 of this Prospectus from the Peer Review Auditors and Statutory Auditor respectively, our Company has not obtained any expert opinions. However, the term “expert” shall not be construed to mean an “expert” as defined under the U.S. Securities Act 1933.

Appraising Entity

The objects of the Issue and deployment of funds are not appraised by any independent agency/ bank/ financial institution.

Underwriting

The Company and the Lead Manager to the Issue hereby confirm that the Issue is 100% Underwritten by the Lead Manager – Hem Securities Limited in the capacity of Underwriter to the Issue.

Pursuant to the terms of the Underwriting Agreement dated April 5, 2014 entered into by us with Underwriter – Hem Securities Limited, the obligations of the Underwriter are subject to certain conditions specified therein. In the opinion of our Board of Directors (based on a certificate given by the Underwriters), the resources of the above mentioned Underwriters are sufficient to enable them to discharge their underwriting obligation in full. The Underwriters are registered with SEBI under Section 12 (1) of the SEBI Act and registered as brokers with the BSE.

Bansal Roofing Products Limited

The Details of the Underwriting commitments are as under:

Details of the Underwriter	No. of shares underwritten	Amount Underwritten (₹ in Lakhs)	% of Total Issue Size Underwritten
Hem Securities Limited 203, Jaipur Tower, M.I. Road, Jaipur, Rajasthan Tel: 0141-2378608, 2363278; Fax: 0141 – 5101 757 Web: www.hemonline.com Email: underwriter@hemonline.com Contact Person: Mr. Anil Bhargava SEBI Regn. No. INM000010981	6,80,000*	204.00	100%

*Includes 36,000 Equity Shares of the Market Maker Reservation Portion which are to be subscribed by the Market Maker (Hem Securities Limited) in its OWN account in order to claim compliance with the requirements of Regulation 106 V (4) of the SEBI (ICDR) Regulations, 2009, as amended.

In the opinion of the Board of Directors of our Company, the resources of the above mentioned Underwriter are sufficient to enable them to discharge their respective obligations in full.

Details of the Market Making Arrangement for this Issue

Our Company has entered into Market Making Agreement dated April 5, 2014 with the following Market Maker, duly registered with BSE Limited to fulfil the obligations of Market Making for this issue:

Name	Hem Securities Ltd.
Correspondence Address:	203, Jaipur Tower, M.I. Road, Jaipur, Rajasthan
Tel No.:	+91 – 141-2378608, 2363278
Fax No.	+91 – 141 – 5101 757
E-mail:	mm@hemonline.com
Website:	www.hemonline.com
Contact Person:	Mr. Anil Bhargava
SEBI Registration No.:	INB011069953
BSE Market Maker Registration No.	SMEMM0024801022013

The Market Maker shall fulfill the applicable obligations and conditions as specified in the SEBI (ICDR) Regulations, and its amendments from time to time and the circulars issued by the BSE and SEBI regarding this matter from time to time.

Following is a summary of the key details pertaining to the Market Making arrangement:

- 1) The Market Maker(s) (individually or jointly) shall be required to provide a 2-way quote for 75% of the time in a day. The same shall be monitored by the stock exchange. Further, the Market Maker(s) shall inform the exchange in advance for each and every black out period when the quotes are not being offered by the Market Maker(s).
- 2) The minimum depth of the quote shall be ₹ 1,00,000.00 . However, the investors with holdings of value less than ₹ 1,00,000.00 shall be allowed to offer their holding to the Market Maker(s) (individually or jointly) in that scrip provided that he sells his entire holding in that scrip in one lot along with a declaration to the effect to the selling broker.
- 3) The Inventory Management and Buying/Selling Quotations and its mechanism shall be as per the relevant circulars issued by SEBI and BSE SME Platform from time to time.
- 4) Execution of the order at the quoted price and quantity must be guaranteed by the Market Maker(s), for the quotes given by him.
- 5) There would not be more than five Market Makers for a scrip at any point of time and the Market Makers may compete with other Market Makers for better quotes to the investors.
- 6) On the first day of the listing, there will be pre-opening session (call auction) and there after the trading will happen as per the equity market hours. The circuits will apply from the first day of the listing on the discovered price during the pre-open call auction.

- 7) The Market maker may also be present in the opening call auction, but there is no obligation on him to do so.
- 8) There will be special circumstances under which the Market Maker may be allowed to withdraw temporarily/fully from the market – for instance due to system problems, any other problems. All controllable reasons require prior approval from the Exchange, while *force-majeure* will be applicable for non controllable reasons. The decision of the Exchange for deciding controllable and non-controllable reasons would be final
- 9) The Market Maker(s) shall have the right to terminate said arrangement by giving a six months notice or on mutually acceptable terms to the Merchant Banker, who shall then be responsible to appoint a replacement Market Maker(s) and execute a fresh arrangement.

In case of termination of the above mentioned Market Making agreement prior to the completion of the compulsory Market Making period, it shall be the responsibility of the Lead Manager to arrange for another Market Maker in replacement during the term of the notice period being served by the Market Maker but prior to the date of releasing the existing Market Maker from its duties in order to ensure compliance with the requirements of regulation 106 V of the SEBI (ICDR) Regulations, 2009, as amended. Further our Company and the Lead Manager reserve the right to appoint other Market Makers either as a replacement of the current Market Maker or as an additional Market Maker subject to the total number of Designated Market Makers does not exceed five or as specified by the relevant laws and regulations applicable at that particular point of time.

The Market Making Agreement is available for inspection at our office from 11.00 a.m. to 5.00 p.m. on working days.

- 10) **Risk containment measures and monitoring for Market Makers:** BSE SME Exchange will have all margins which are applicable on the BSE Main Board viz., Mark-to-Market, Value-At-Risk (VAR) Margin, Extreme Loss Margin, Special Margins and Base Minimum Capital etc. BSE can impose any other margins as deemed necessary from time-to-time.
- 11) **Punitive Action in case of default by Market Makers:** BSE SME Exchange will monitor the obligations on a real time basis and punitive action will be initiated for any exceptions and/or non-compliances. Penalties / fines may be imposed by the Exchange on the Market Maker, in case he is not able to provide the desired liquidity in a particular security as per the specified guidelines. These penalties / fines will be set by the Exchange from time to time. The Exchange will impose a penalty on the Market Maker in case he is not present in the market (offering two way quotes) for at least 75% of the time. The nature of the penalty will be monetary as well as suspension in market making activities / trading membership.

The Department of Surveillance and Supervision of the Exchange would decide and publish the penalties / fines / suspension for any type of misconduct/ manipulation/ other irregularities by the Market Maker from time to time.

- 12) **Price Band and Spreads:** SEBI Circular bearing reference no: CIR/MRD/DP/ 02/2012 dated January 20, 2012, has laid down that for issue size up to ₹ 250 Crores, the applicable price bands for the first day shall be:
 - i In case equilibrium price is discovered in the Call Auction, the price band in the normal trading session shall be 5% of the equilibrium price.
 - ii In case equilibrium price is not discovered in the Call Auction, the price band in the normal trading session shall be 5% of the issue price.

Additionally, the trading shall take place in TFT segment for first 10 days from commencement of trading. The following spread will be applicable on the BSE SME Exchange/ Platform.

Sr. No.	Market Price Slab (in ₹)	Proposed spread (in % to sale price)
1	Up to 50	9
2	50 to 75	8
3	75 to 100	6
4	Above 100	5

- 13) **All the above mentioned conditions and systems regarding the Market Making Arrangement are subject to change based on changes or additional regulations and guidelines from SEBI and Stock Exchange from time to time.**

CAPITAL STRUCTURE

The Share Capital of our Company as on the date of this Prospectus is set forth below:

(₹ in Lakhs, except share data)

S. No.	Particulars	Aggregate Value at Face Value (₹)	Aggregate Value at Issue Price (₹)
A	Authorized Share Capital 1,00,00,000 Equity Shares having Face Value of ₹ 10.00 each	1000.00	-
B	Issued, Subscribed & Paid-up Share Capital prior to the Issue 15,17,200 Equity Shares having Face Value of ₹ 10.00 each	151.72	-
C	Present Issue in terms of this Prospectus* 6,80,000 Equity Shares having Face Value of ₹ 10.00 each at a Premium of ₹ 20.00 per share	68.00	204.00
	Which Comprises		
I.	Reservation for Market Maker portion 36,000 Equity Shares of ₹ 10.00 each at a premium of ₹ 20.00 per Equity Share	3.60	10.80
II.	Net Issue to the Public 6,44,000 Equity Shares of ₹ 10.00 each at a premium of ₹ 20.00 per Equity Share	64.40	193.20
	of which		
	3,22,000 Equity Shares of ₹ 10.00 each at a premium of ₹ 20.00 per Equity Share will be available for allocation for allotment to Retail Individual Investors of up to ₹ 2.00 Lakhs	32.20	96.60
	3,22,000 Equity Shares of ₹ 10.00 each at a premium of ₹ 20.00 per Equity Share will be available for allocation for allotment to Other Investors of above ₹ 2.00 Lakhs	32.20	96.60
D	Paid up Equity capital after the Issue 21,97,200 Equity Shares having Face Value of ₹ 10.00 each	219.72	-
E	Securities Premium Account Before the Issue After the Issue	00.00 136.00	

*The present Issue of 6,80,000 Equity Shares in terms of this Prospectus has been authorized pursuant to a resolution of our Board of Directors dated January 09, 2014 and by special resolution passed under Section 81 & 81(1A) of the Companies Act, 1956 at the Extra-ordinary General Meeting of the members held on January 20, 2014. Our Company does not have any outstanding convertible instruments as on the date of this Prospectus

Classes of Shares

The Company has only one class of share capital i.e. Equity Shares of ₹ 10.00 each only.

Notes to Capital Structure

1. Details of Increase / Changes in Authorized Share Capital of our Company:

Date of Meeting/ Share Holders Approval	Details of Changes
05.09.2011	Increase in the authorized share capital of the Company from ₹ 1.00 Lakh divided into 10,000 Equity Shares of ₹ 10.00 each to ₹ 10.00 Lakhs divided into 1,00,000 Equity Shares of ₹ 10.00 each.
08.02.2013	Increase in the authorized share capital of the Company from ₹ 10.00 Lakhs divided into 1,00,000 Equity Shares of ₹ 10.00 each to ₹ 100.00 Lakhs divided into 10,00,000 Equity Shares of ₹ 10.00 each.
24.08.2013	Increase in the authorized share capital of the Company from ₹ 100.00 Lakhs divided into 10,00,000 Equity Shares of ₹ 10.00 each to ₹ 1000.00 Lakhs divided into 1,00,00,000 Equity Shares of ₹ 10.00 each.

On Incorporation, the initial authorized share capital of the Company comprised of ₹ 1,00,000.00 divided into 10,000 Equity Shares of ₹10.00 each

2. Equity Share Capital History of our Company:

Date of Allotment / Date of Fully Paid Up	No. of Equity Shares allotted	Cumulative No. of Equity Shares	Face Value (₹)	Issue Price (₹)	Cumulative Securities Premium Account (₹)	Cumulative Paid-up Capital (₹)	Consideration	Nature of Issue and Category of Allottees
01.05.2008 [#]	10,000	10,000	10.00	10.00	Nil	1,00,000	Cash	Initial Subscription to MOA ¹
24.09.2011	90,000	1,00,000	10.00	10.00	Nil	10,00,000	Cash	Further Allotment ²
01.03.2013	9,00,000	10,00,000	10.00	10.00	Nil	1,00,00,000	Cash	Further Allotment ³
23.01.2014	5,17,200	15,17,200	10.00	-	Nil	1,51,72,000	Bonus Issue (Ratio 12:1)	Bonus Issue ⁴ to equity Shareholders.

[#] The Allotment of Equity Shares to the Subscribers to the Memorandum of Association of the Company was made in the meeting of the Board of Directors of our Company on May 1, 2008.

All the allotments of Equity Shares of our Company were made as fully paid-up equity shares of face value of ₹ 10/- each.

i.

Name	No. of Shares
Mr. Kaushalkumar S. Gupta	6,000
Mrs. Sangeeta K. Gupta	2,000
Mr. Satishkumar S. Gupta	2,000
Total	10,000

ii.

Name	No. of Shares
Mr. Kaushalkumar S. Gupta	54,000
Mrs. Sangeeta K. Gupta	26,000
Mr. Satishkumar S. Gupta	10,000
Total	90,000

iii.

Name	No. of Shares
Mr. Kaushalkumar S. Gupta	8,80,000
Mr. Ashishkumar S. Gupta	20,000
Total	9,00,000

iv. Bonus Issue of 5,17,200 fully paid up Equity Shares of ₹ 10.00 each were made in the ratio of 12 Equity Shares for every 1 Equity Share held. Mr. Kaushalkumar S. Gupta had voluntarily forgone his part of the bonus issue.

Name	No. of Shares
Mrs. Sangeeta K. Gupta	3,36,000
Mr. Satishkumar S. Gupta	1,44,000
Mr. Ashishkumar S. Gupta	12,000
Mr. Niladri S. Seal	12,000
Mr. Nikhil M. Patel	12,000
Mr. Tushar D. Suthar	12,000
Total	5,17,200

Bansal Roofing Products Limited

3. Details of Allotment made in the last two years preceding the date of the Prospectus:

Date of Allotment / Date of Fully Paid Up	No. of Equity Shares allotted	Cumulative No. of Equity Shares	Face Value (₹)	Issue Price (₹)	Cumulative Securities Premium Account (₹)	Cumulative Paid-up Capital (₹)	Consideration	Nature of Issue and Category of Allottees
01.03.2013	9,00,000	10,00,000	10.00	10.00	Nil	1,00,00,000	Cash	Further Allotment
23.01.2014	5,17,200	15,17,200	10.00	-	Nil	1,51,72,000	Bonus Issue (Ratio 12:1)	Bonus Issue ¹ to equity Shareholders.

¹Except for allotment of Bonus shares out of free reserves of the Company, no shares have been issued for consideration other than cash in last two years.

4. Details of Equity Shares issued for consideration other than cash:

As on date, our Company has not issued any Equity Shares for consideration other than cash except for Bonus Shares issued as mentioned above in sub point no. 4 of note no. 2 above. Brief details of the same is as under:-

Date of Allotment	No. of Equity Shares allotted	Face Value (₹)	Issue Price (₹)	Reasons	Benefit accrued
23.01.2014	5,17,200	10.00	Nil	Bonus Issue in the Ratio 12:1	To reward the shareholders as our Company has made profits.

Since the issue was by way of capitalization of reserves, no benefits has accrued to the Company out of the above issuance.

5. Capital Build Up in respect of shareholding of Our Promoters:

Date of Allotment/ Acquisition / Transfer of Fully Paid- up Shares	Consideration	Nature of Issue	No. of Equity Shares*	Face Value (₹)	Issue Price/ Acquisition Price**/ Transfer Price (₹)	% of Pre-issue paid up capital	% of Post-issue paid up capital
Mr. Kaushalkumar S. Gupta							
01.05.2008	Cash	Subscribed to the Memorandum	6,000	10.00	10.00	0.40	0.27
24.09.2011	Cash	Further Allotment	54,000	10.00	10.00	3.56	2.46
01.03.2013	Cash	Further Allotment	8,80,000	10.00	10.00	58.00	40.05
28.07.2013	Cash	Transfer to Niladri S. Seal	(1,000)	10.00	15.88	-0.07	-0.05
28.07.2013	Cash	Transfer to Nikhil M. Patel	(1,000)	10.00	15.88	-0.07	-0.05
28.07.2013	Cash	Transfer to Tushar D. Suthar	(1,000)	10.00	15.88	-0.07	-0.05
03.10.2013	Cash	Acquired from Ashishkumar S. Gupta	19,900	10.00	15.88	1.31	0.91
Total (A)			9,56,900			63.07	43.55
Mrs. Sangeeta K. Gupta							
01.05.2008	Cash	Subscribed to the Memorandum	2,000	10.00	10.00	0.13	0.09
24.09.2011	Cash	Further Allotment	26,000	10.00	10.00	1.71	1.18
23.01.2014	-	Bonus Issue (Ratio 12:1)	3,36,000	10.00	Nil	22.15	15.29
Total (B)			3,64,000			23.99	16.57
Total no. of Equity Shares as on the date of Prospectus (A+B)			13,20,900			87.06	60.12

*None of the shares has been pledged by our Promoters

** Acquisition price excludes stamp duty.

Bansal Roofing Products Limited

6. The average cost of acquisition of or subscription of shares by our promoters is set forth in the table below:

Sr. No.	Name of the Promoter	No. of Shares held	Average cost of Acquisition (in ₹)
1.	Mr. Kaushalkumar S. Gupta	9,56,900	10.10
2.	Mrs. Sangeeta K. Gupta	3,64,000	0.77

7. Details of the Pre and Post Issue Shareholding of our Promoters and Promoter Group is as below:

Name	Pre Issue		Post Issue	
	No. of Shares	as a % of Issued Equity	No. of Shares	as a % of Issued Equity
Promoters				
Mr. Kaushalkumar S. Gupta	9,56,900	63.07%	9,56,900	43.55%
Mrs. Sangeeta K. Gupta	3,64,000	23.99%	3,64,000	16.57%
Promoter Group				
Mr. Satishkumar S. Gupta	1,56,000	10.28%	1,56,000	7.10%
Total	14,76,900	97.34%	14,76,900	67.22%

8. Promoter's Contribution and Lock-in:

The following shares held by Promoter are locked-in as Promoter's Contribution:

Date of Allotment/ Acquisition of Fully Paid- up Shares	Nature of Issue & Consideration	No. of Equity Shares	Face Value (₹)	Issue Price / Consideration (₹ per share)	% of Pre-issue paid up capital	Source of Funds contributed	% of Post-issue paid up capital	Lock in period
Mr. Kaushalkumar S. Gupta								
01.05.2008	Subscribed to MOA	3,000	10.00	10.00	0.20	Owned	0.14	3 years
24.09.2011	Further Allotment	54,000	10.00	10.00	3.56	Owned	2.46	
01.03.2013	Further Allotment	8,80,000	10.00	10.00	58.00	Partly Owned, Partly from Financial Arrangement*	40.05	
Total (A)		9,37,000			61.76		42.65	
Mrs. Sangeeta K. Gupta								
01.05.2008	Subscribed to MOA	2,000	10.00	10.00	0.13	Owned	0.09	3 years
24.09.2011	Further Allotment	26,000	10.00	10.00	1.71	Owned	1.18	
23.01.2014	Bonus Issue (Ratio 12:1)	3,36,000	10.00	-	22.15	Not Applicable, Bonus Shares	15.29	
Total (B)		3,64,000			23.99		16.57	
Total (A+B)		13,01,000			85.75		59.21	

*Our Promoter Mr. Kaushalkumar S. Gupta had been allotted 8,80,000 Equity Share on March 1, 2013. For the said allotment Mr. Kaushalkumar S. Gupta had paid ₹ 30,00,000.00 from his owned source and ₹ 58,00,000.00 have been arranged from State Bank of India, Sayaji Gunj branch, Vadodra Branch- 390 005 through Cash Credit at an Interest Rate of Base Rate(10.00%) + 4.75% sanctioned to M/S. Agarwal Associates, a proprietorship concern of Mr. Kaushalkumar Gupta.

All Equity Shares, which are being locked in are not ineligible for computation of Minimum Promoters Contribution as per Regulation 33 of the SEBI ICDR Regulations and are being locked in for 3 years as per Regulation 36(a) of the SEBI ICDR Regulations i.e. for a period of three years from the date of allotment of Equity Shares in this issue.

Bansal Roofing Products Limited

No Equity Shares proposed to be locked-in as Minimum Promoters Contribution have been issued out of revaluation reserve or for consideration other than cash and revaluation of assets or capitalisation of intangible assets, involved in such transactions.

The entire eligible pre-issue shareholding of the Promoters is locked in for a period of three years by way of Minimum Promoters Contribution from the date of allotment in this Issue.

Our Promoters, Mr. Kaushalkumar S. Gupta and Mrs. Sangeeta K. Gupta, have by a written undertaking, consented to have 13,01,000 Equity Shares held by them to be locked in as Minimum Promoters Contribution for a period of 3 (three) years from the date of allotment in this Issue and will not be disposed / sold / transferred by the promoters during the period starting from the date of filing the Prospectus with SME Platform of BSE till the date of commencement of lock-in period as stated in the Prospectus. The Equity Shares under the Promoters contribution will constitute 59.21 % of our post-issue paid up share capital.

Our Promoters have also consented that the Promoter contribution under Regulation 32 of the SEBI ICDR Regulations will not be less than 20% of the post issue paid up capital of our Company.

Eligibility of Share for “Minimum Promoters Contribution in terms of clauses of Regulation 33 (1) of SEBI (ICDR) Regulations, 2009

Reg. No.	Promoters’ Minimum Contribution in-eligibility Conditions	Eligibility Status of Equity Shares forming part of Promoter’s Contribution
33(1) (a) (i)	Specified securities acquired during the preceding three years, if they are acquired for consideration other than cash and revaluation of assets or capitalisation of intangible assets is involved in such transaction	Eligible
33 (1) (a) (ii)	Specified securities acquired during the preceding three years, resulting from a bonus issue by utilisation of revaluation reserves or unrealized profits of the issuer or from bonus issue against Equity Shares which are ineligible for minimum promoters’ contribution	Eligible
33 (1) (b)	Specified securities acquired by promoters during the preceding one year at a price lower than the price at which specified securities are being offered to public in the initial public offer	Eligible
33 (1) (c)	Specified securities allotted to promoters during the preceding one year at a price less than the issue price, against funds brought in by them during that period, in case of an issuer formed by conversion of one or more partnership firms, where the partners of the erstwhile partnership firms are the promoters of the issuer and there is no change in the management: Provided that specified securities, allotted to promoters against capital existing in such firms for a period of more than one year on a continuous basis, shall be eligible	Eligible
33 (1) (d)	Specified securities pledged with any creditor.	Eligible

Details of Share Capital Locked In For One Year

In terms of Regulation 36(b) and 37 of the SEBI ICDR Regulations, in addition to the Minimum Promoters contribution which is locked in for 3 (three) years, as specified above, the entire pre-issue capital held by promoters, which is ineligible for promoter’s contribution and entire pre-issue capital held by persons other than promoters of our Company i.e. promoter group entities and public shareholders, constituting 2,16,200 Equity Shares shall be locked in for a period of 1 (One) year from the date of allotment of Equity Shares in this Issue.

The Equity Shares which are subject to lock-in shall carry inscription ‘non transferable’ along with the duration of specified non-transferable period mentioned in the face of the security certificate. The shares which are in dematerialized form, if any, shall be locked-in by the respective depositories. The details of lock-in of the Equity Shares shall also be provided to the Designated Stock Exchange before the listing of the Equity Shares.

Other requirements in respect of lock-in:

- a) In terms of Regulation 39 of the SEBI ICDR Regulations, the locked in Equity Shares held by the Promoters, as specified above, can be pledged with any scheduled commercial bank or public financial institution as collateral security for loan granted by such bank or institution provided that the pledge of Equity Shares is one of the terms of the sanction of the loan. Provided that securities locked in as minimum promoter contribution may be pledged only if, in addition to fulfilling the above requirements, the loan has been granted by such bank or institution, for the purpose of financing one or more of the objects of the Issue.
- b) In terms of Regulation 40 of the SEBI ICDR Regulations, the Equity Shares held by persons other than the Promoters prior to the Issue may be transferred to any other person holding the Equity Shares which are locked in as per Regulation 36 or 37 of the SEBI ICDR Regulations, subject to continuation of the lock-in in the hands of the transferees for the remaining period and compliance with the SEBI (Substantial Acquisition of Shares and Takeovers) Regulations, 2011, as applicable.
- c) Further in terms of Regulation 40 of the SEBI ICDR Regulations, the Equity Shares held by the Promoters may be transferred to and amongst the Promoter Group or to new promoters or persons in control of the Issuer subject to continuation of the lock-in in the hands of the transferees for the remaining period and compliance with SEBI (Substantial Acquisition of Shares and Takeovers) Regulations, 2011, as applicable.

9. Our Shareholding pattern

The table below presents the current shareholding pattern of our Company as per clause 37 of the SME Equity Listing Agreement.

Category code	Category of shareholder	No. of shareholders	Total no. of shares	Number of shares held in dematerialized form	Total shareholding as a % of total number of shares		Shares Pledged or otherwise encumbered	
					As a % of (A+B)	As a % of (A+B+C)	Number of Shares	As a % of Shareholding
(A)	Promoter and Promoter Group							
(1)	Indian							
(a)	Individuals/ Hindu Undivided Family	3	14,76,900	14,76,900	97.34	97.34	Nil	Nil
(b)	Central Government/ State Government(s)	Nil	Nil	Nil	Nil	Nil	Nil	Nil
(c)	Bodies Corporate	Nil	Nil	Nil	Nil	Nil	Nil	Nil
(d)	Financial Institutions/ Banks	Nil	Nil	Nil	Nil	Nil	Nil	Nil
(e)	Any Other (specify)	Nil	Nil	Nil	Nil	Nil	Nil	Nil
	Sub-Total (A)(1)	3	14,76,900	14,76,900	97.34	97.34	Nil	Nil
(2)	Foreign							
(a)	Individuals (Non-Resident) Individuals/ Foreign Individuals	Nil	Nil	Nil	Nil	Nil	Nil	Nil
(b)	Bodies Corporate	Nil	Nil	Nil	Nil	Nil	Nil	Nil
(c)	Institutions	Nil	Nil	Nil	Nil	Nil	Nil	Nil
(d)	Any Other (specify)	Nil	Nil	Nil	Nil	Nil	Nil	Nil

Bansal Roofing Products Limited

Category code	Category of shareholder	No. of shareholders	Total no. of shares	Number of shares held in dematerialized form	Total shareholding as a % of total number of shares		Shares Pledged or otherwise encumbered	
					As a % of (A+B)	As a % of (A+B+C)	Number of Shares	As a % of Shareholding
	Sub-Total (A) (2)	Nil	Nil	Nil	Nil	Nil	Nil	Nil
	Total Promoters and Promoter group Shareholding (A)= A(1)+A(2)	3	14,76,900	14,76,900	97.34	97.34	Nil	Nil
(B)	Public shareholding							
(1)	Institutions							
(a)	Mutual Funds/UTI	Nil	Nil	Nil	Nil	Nil	Nil	Nil
(b)	Financial Institutions/ Banks	Nil	Nil	Nil	Nil	Nil	Nil	Nil
(c)	Central Government/ State Government(s)	Nil	Nil	Nil	Nil	Nil	Nil	Nil
(d)	Venture Capital Funds	Nil	Nil	Nil	Nil	Nil	Nil	Nil
(e)	Insurance Companies	Nil	Nil	Nil	Nil	Nil	Nil	Nil
(f)	Foreign Institutional Investors	Nil	Nil	Nil	Nil	Nil	Nil	Nil
(g)	Foreign Venture Capital Investors	Nil	Nil	Nil	Nil	Nil	Nil	Nil
(h)	Nominated investors (as defined in Chapter XA of SEBI (ICDR) Regulations)	Nil	Nil	Nil	Nil	Nil	Nil	Nil
(i)	Market Makers	Nil	Nil	Nil	Nil	Nil	Nil	Nil
(h)	Any Other (specify)	Nil	Nil	Nil	Nil	Nil	Nil	Nil
	Sub-Total (B) (1)	Nil	Nil	Nil	Nil	Nil	Nil	Nil
(2)	Non- institutions							
(a)	Bodies Corporate	Nil	Nil	Nil	Nil	Nil	Nil	Nil
(b)	Individuals - i. Individual shareholders holding Nominal share capital up to ₹ 1 Lakh.	1	1,300	1,300	0.09	0.09	Nil	Nil
	ii. Individual shareholders holding Nominal share capital in excess of ₹ 1 Lakh.	3	39,000	39,000	2.57	2.57	Nil	Nil

Bansal Roofing Products Limited

Category code	Category of shareholder	No. of shareholders	Total no. of shares	Number of shares held in dematerialized form	Total shareholding as a % of total number of shares		Shares Pledged or otherwise encumbered	
					As a % of (A+B)	As a % of (A+B+C)	Number of Shares	As a % of Shareholding
(c)	Any Other (specify)	Nil	Nil	Nil	Nil	Nil	Nil	Nil
	Sub-Total (B) (2)	4	40,300	40,300	2.66	2.66	Nil	Nil
	Total Public Shareholding (B) = (B) (1) + (B) (2)	4	40,300	40,300	2.66	2.66	Nil	Nil
	TOTAL (A) +(B)	7	15,17,200	15,17,200	100.00	100.00	Nil	Nil
(C)	Shares held by Custodians and against which Depository Receipts have been issued							
(a)	Promoters and Promoter Group	Nil	Nil	Nil	Nil	Nil	Nil	Nil
(b)	Public	Nil	Nil	Nil	Nil	Nil	Nil	Nil
	Total Shares held by Custodians and against which Depository Receipts have been issued (C)	Nil	Nil	Nil	Nil	Nil	Nil	Nil
	GRAND TOTAL (A) + (B) + (C)	7	15,17,200	15,17,200	100.00	100.00	Nil	Nil

We have entered into tripartite agreement with NSDL & CDSL and have received the ISIN - INE319Q01012. As on date entire issued equity shares of the Company is in dematerialised form.

Our Company will file the shareholding pattern of our Company, in the form prescribed under Clause 37 of the Listing Agreement, one day prior to the listing of the Equity shares. The Shareholding pattern will be uploaded on the website of BSE before commencement of trading of such Equity Shares.

10. The Top Ten Shareholders of our Company and their Shareholding is set forth below:-

As on the date of the Prospectus, our Company has 7 (Seven) shareholders.

- (a) Our top ten shareholders as on the date of filing of this Prospectus and 10 days prior filing of this Prospectus are as follows:

S. No.	Name of the Shareholders	No. of Shares	% of Pre-issue paid up capital
1.	Mr. Kaushalkumar S. Gupta	9,56,900	63.07
2.	Mrs. Sangeeta K. Gupta	3,64,000	23.99
3.	Mr. Satishkumar S. Gupta	1,56,000	10.28
4.	Mr. Ashishkumar S. Gupta	1,300	0.09
5.	Mr. Niladri S. Seal	13,000	0.86
6.	Mr. Nikhil M. Patel	13,000	0.86
7.	Mr. Tushar D. Suthar	13,000	0.86
	Total	15,17,200	100.00

- (b) Details of top ten shareholders of our Company as on two years prior to the date of filing of this Prospectus, are as follows:

Bansal Roofing Products Limited

S. No.	Name of the Shareholders	No. of Shares	% of paid up capital (Two years prior to the date of Prospectus, represented by 1,00,000 Equity Shares)
1.	Mr. Kaushalkumar S. Gupta	60,000	60.00
2.	Mrs. Sangeeta K. Gupta	28,000	28.00
3.	Mr. Satishkumar S. Gupta	12,000	12.00
	Total	1,00,000	100.00

11. None of our public shareholders holds more than 1% equity shares of the pre-Issue share capital of our Company as on the date of this Prospectus.
12. Except as provided below, there has been no subscription to or sale or purchase of the securities of our Company within 3 (three) years preceding the date of filing of this Prospectus by our Promoters or Directors or Promoter Group which in aggregate equals to or is greater than 1% of the Pre-Issue share capital of our Company.

S. No.	Name of Shareholder	Promoter/Promoter Group/Director	Number Equity Shares	Subscribed/Purchased or Sold
1.	Mr. Kaushalkumar S. Gupta	Promoter & Director	54,000	Subscribed
2.	Mrs. Sangeeta K. Gupta	Promoter & Director	26,000	Subscribed
3.	Mr. Satishkumar S. Gupta	Promoter Group & Director	10,000	Subscribed
4.	Mr. Kaushalkumar S. Gupta	Promoter & Director	8,80,000	Subscribed
5.	Mr. Kaushalkumar S. Gupta	Promoter & Director	19,900	Purchased
6.	Mrs. Sangeeta K. Gupta	Promoter & Director	3,36,000	Subscribed (Bonus Issue)
7.	Mr. Satishkumar S. Gupta	Promoter Group & Director	1,44,000	Subscribed (Bonus Issue)

13. No Equity Shares have purchased or sold by our Promoters, Promoter Group and/or by our Directors and their immediate relatives within six months immediately preceding the date of filing of this Prospectus are.
14. Except for bonus issue made by our Company for 5,17,200 Equity Shares details in respect of which have been mentioned at point no. 2(iv) above, none of Equity Shares issued by our Company were issue at a price lower than the Issue price during the preceding one year from the date of this Prospectus.
15. None of our Promoter, Promoter Group, Directors and their relatives has entered into any financing arrangement or financed the purchase of the Equity Shares of our Company by any other person during the period of six months immediately preceding the date of filing of Prospectus.
16. As on the date of filing of the Prospectus, there are no outstanding warrants, options or rights to convert debentures, loans or other instruments which would entitle Promoters or any shareholders or any other person any option to acquire our Equity Shares after this Initial Public Offer.
17. As on the date of this Prospectus, the entire Issued, Subscribed and Paid-up Share Capital of our Company is fully paid up.
18. Our Company has not raised any bridge loan against the proceeds of the Issue.
19. Since the entire issue price per share is being called up on application, all the successful applicants will be allotted fully paid-up shares.
20. As on the date of this Prospectus, none of the shares held by our Promoter / Promoter Group are subject to any pledge.
21. Neither, we nor our Promoters, Directors and the LM to this Issue have entered into any buyback and / or standby arrangements and / or similar arrangements for the purchase of our Equity Shares from any person.
22. The LM and their associates do not hold any Equity Shares in our Company as on the date of filing of Prospectus.
23. There will be no further issue of capital whether by way of issue of bonus shares, preferential allotment, rights issue or in any other manner during the period commencing from the date of the Prospectus until the Equity Shares offered have been listed or application moneys refunded on account of failure of Issue.

Bansal Roofing Products Limited

24. Our Company does not presently intend or propose to alter its capital structure for a period of six months from the date of opening of the Issue, by way of split or consolidation of the denomination of Equity Shares or further issue of Equity Shares (including issue of securities convertible into or exchangeable, directly or indirectly for Equity Shares) whether preferential or otherwise. This is except if we enter into acquisition or joint ventures or make investments, in which case we may consider raising additional capital to fund such activity or use Equity Shares as a currency for acquisition or participation in such joint ventures or investments.
25. None of our Equity Shares have been issued out of revaluation reserve created out of revaluation of assets.
26. An over-subscription to the extent of 10% of the Issue can be retained for the purpose of rounding off to the nearest integer during finalizing the allotment, subject to minimum allotment, which is the minimum application size in this Issue. Consequently, the actual allotment may go up by a maximum of 10% of the Issue, as a result of which, the post-issue paid up capital after the Issue would also increase by the excess amount of allotment so made. In such an event, the Equity Shares held by the Promoter and subject to 3 year lock- in shall be suitably increased; so as to ensure that 20% of the post Issue paid-up capital is locked in.
27. Under subscription, if any, in any of the categories, would be allowed to be met with spill-over from any of the other categories or a combination of categories at the discretion of our Company in consultation with the LM and the Designated Stock Exchange i.e. BSE. Such inter-se spill over, if any, would be affected in accordance with applicable laws, rules, regulations and guidelines.
28. In case of over-subscription in all categories the allocation in the issue shall be as per the requirements of Regulation 43 (4) of SEBI (ICDR) Regulations, 2009 and its amendments from time to time.
29. At any given point of time there shall be only one denomination of the Equity Shares, unless otherwise permitted by law.
30. Our Company shall comply with such disclosure and accounting norms as may be specified by BSE, SEBI and other regulatory authorities from time to time.
31. As on the date of this Prospectus, we do not have any Employees Stock Option Scheme/Employees Stock Purchase Scheme.
32. We have 7 (Seven) Shareholders as on the date of filing of the Prospectus.
33. Till date our Company has not made any allotted of Equity Shares pursuant to any scheme approved under section 391- 394 of the Companies Act, 1956.
34. Our Promoters and Promoter Group will not participate in this Issue.
35. This issue is being made through Fixed Price method.
36. Our Company has not made any public issue or rights issue of any kind or class of securities since its incorporation.
37. No person connected with the Issue shall offer any incentive, whether direct or indirect, in the nature of discount, commission, and allowance, or otherwise, whether in cash, kind, services or otherwise, to any Applicant.
38. There are no safety net arrangements for this public issue.
39. We shall ensure that transactions in Equity Shares by the Promoters and members of the Promoter Group, if any, between the date of registering this Prospectus with the RoC and the Issue Closing Date are reported to the Stock Exchanges within 24 hours of such transactions being completed.

OBJECTS OF THE ISSUE

The Issue includes a fresh Issue of 6,80,000 Equity Shares of our Company at an Issue Price of ₹ 30.00 per Equity Share. Our Company proposes to utilise the funds which are being raised through this Issue towards the below mentioned objects and gain benefits of listing on SME platform of BSE:

The objects of the Issue are:-

- To meet Long Term Working Capital Requirement.
- General Corporate Purposes.
- To Meet the Issue Expenses

(Collectively referred as the “*objects*”)

We believe that listing will enhance our corporate image and brand name and create a public market for Equity Share of our Company in India. We also believe that the listing of our Equity Shares will enhance our visibility and brand name and enable us to avail future growth opportunities Our Company is primarily engaged in the manufacturing of roofing sheets, accessories and ventilation solution. The main objects clause of our Memorandum enables our Company to undertake its existing activities and these activities which have been carried out until now by our Company are valid in terms of the objects clause of our Memorandum.

Requirement of funds

The following table summarizes the requirement of funds:

		(₹ In Lakhs)
Sr. No.	Particulars	Amount
1	To meet Long Term Working Capital Requirement	154.00
2	General Corporate Purposes	10.00
3	Public Issue Expenses	40.00
	Total	204.00

Means of Finance

		(₹ In Lakhs)
Sr. No.	Particulars	Amount
1	Public Issue Proceeds	204.00
	Total	204.00

Since the entire fund requirements are to be funded from the proceeds of the Issue. Accordingly, there is no requirement to make firm arrangements of finance under Regulation 4(2)(g) of the SEBI ICDR Regulations through verifiable means towards at least 75% of the stated means of finance, excluding the amounts to be raised through the proposed Issue.

The fund requirement and deployment is based on internal management estimates and have not been appraised by any bank or financial institution. These are based on current conditions and are subject to change in the light of changes in external circumstances or costs or other financial conditions and other external factors.

In case of any increase in the actual utilization of funds earmarked for the Objects, such additional funds for a particular activity will be met by way of means available to our Company, including from internal accruals. If the actual utilization towards any of the Objects is lower than the proposed deployment such balance will be used for future growth opportunities including funding existing objects, if required and general corporate purposes. In case of delays in raising funds from the Issue, our company may deploy certain amounts towards any of the above mentioned Objects through a combination of Internal Accruals or Unsecured Loans (Bridge Financing) and in such case the Funds raised shall be utilized towards repayment of such Unsecured Loans or recouping of Internal Accruals. However, we confirm that no bridge financing has been availed as on date, which is subject to being repaid from the Issue Proceeds.

As we operate in competitive environment, our Company may have to revise its business plan from time to time and consequently our capital requirements may also change. Our Company’s historical capital expenditure may not be

Bansal Roofing Products Limited

reflective of its future capital expenditure plans. Our Company may have to revise its estimated costs, fund allocation and fund requirements owing to factors such as economic and business conditions, increased competition and other external factors which may not be within the control of its management. This may entail rescheduling or revising the planned expenditure and funding requirements, including the expenditure for a particular purpose at the discretion of the Company's management.

For further details on the risks involved in our business plans and executing our business strategies, please see the section titled "**Risk Factors**" beginning on page 11 of this Prospectus

Details of the use of the proceeds

1. To meet Long Term Working Capital Requirement

Our Company's business is working capital intensive and our Company funds majority of its working capital requirements in the ordinary course of our business from internal accruals and from various banks and financial institutions. As on December 31, 2013, our sanctioned working capital facility consists of an aggregate fund based limit of ₹ 200 Lacs. For further details of the working capital facility currently availed by us, please refer to "**Restated Statement of Secured borrowings**" in the chapter "**Financial Information of the Company**" and the chapter "**Financial Indebtedness**" on page 130 and 140 respectively.

Based on internal estimates and projections as reflected below, our Company would require total working capital of ₹ 402.48 Lacs during the Financial Year 2014-15. As on date we have a Cash Credit limit of ₹ 200.00 from State Bank of India. Our Company proposes to utilise ₹ 154.00 Lacs out of the Issue proceeds to meet the increase in long term working capital requirements.

Inventory, Debtors, Advances, Creditors have been taken at various levels, which is in consonance with the industry practices and past trends. The estimates of working capital requirement are based on the management's internal estimates which are as follows:

Basis of estimation of working capital requirement and estimated working capital requirement:

(₹ in Lacs)

Sr. No.	Particulars	Audited	Holding level (No. of Days)	Audited	Holding level (No. of Days)	Estimated	Holding level (No. of Days)
		31-Mar-13		31-Dec-13		31-Mar-15	
I	Current Assets						
	Inventories	222.29	30.76	237.56	65.68	352.89	50.89
	Trade Receivables	195.81	41.66	30.48	7.88	257.82	40.00
	Cash and cash equivalents	4.61		38.62		44.41	
	Other Current Assets	31.87		50.89		58.52	
	Short-term Loans and Advances	1.55		46.18		53.10	
	Total	456.13		403.72		766.75	
II	Current Liabilities						
	Short-term Borrowings	33.96		60.51		69.59	
	Sundry Creditors	216.50	46.06	146.27	37.82	203.37	30.00
	Other Trade Payables	13.40		8.70		10.00	
	Other current liabilities	7.00		55.14		63.42	
	Short-term provisions	23.06		15.56		17.90	
	Total	293.92		286.19		364.27	
III	Total Working Capital Gap	162.21		117.53		402.48	
IV	Funding Pattern						
	From IPO Proceeds	0.00		0.00		154.00	
	Bank Borrowing & Internal Accruals	162.21		117.53		248.48	

The incremental long term working capital requirements are based on Company's historical data and estimation of the future requirements in financial year 2014-15 considering the growth in activities of our Company.

Justification for holding period levels

Inventories	Inventory holding levels are expected to increase from 30.76 days in the Financial Year 2012-13 to 50.89 days in the Financial Year 2013-14.
Trade Receivables	Trade Receivables (in terms of number of days) are expected to reduce by ensuring uniform sales throughout the year, and monitoring and implementing improved credit management from 41.66 to 40 days.
Sundry Creditors	To ensure smooth supplies from our vendors, there would be a marginal reduction in our Creditors level from last year 46.06 to 30 days.

2. General Corporate Purposes

We intend to use approximately ₹ 10.00 Lakhs from the Proceeds of the Issue towards general corporate purposes as decided by our Board from time to time, including but not restricted to for our working capital requirements, bank deposits, strategic initiatives, expansion into new geographies, brand building exercises, strengthening of our marketing capabilities and to strengthen our operations.

Our management, in accordance with the policies of our Board, will have flexibility in utilizing the proceeds earmarked for general corporate purposes.

3. Public Issue Expenses

The estimated issue related expenses include, among others, underwriting and selling commissions, printing and distribution expenses, legal fees, advertisement expenses, registrar’s fees, depository fees and listing Fees. The total expenses for this Issue are estimated to be approximately ₹ 40.00 Lakhs which is 19.61% of the Issue Size.. All the Issue related expenses shall be met out of the proceeds of the Issue and the break-up of the same is as follows:

Activity	Expenses (₹ in Lakhs)
Payment to Merchant Banker including, underwriting and selling commissions, brokerages, payment to other intermediaries such as Legal Advisors, Registrars, Bankers etc and other out of pocket expenses	32.00
Printing and Stationery and postage expenses	3.00
Advertising and Marketing expenses	2.00
Regulatory fees and expenses	3.00
Total estimated Issue Expenses	40.00

Proposed year-wise Deployment of Funds and Schedule of Implementation:

The proposed year wise break up of deployment of funds is as under:

(₹ in Lakhs)

Sr. No.	Particulars	Amount already incurred as on date	Amount to be deployed in F.Y. 2014-15
1	Long Term Working Capital	0.00	154.00
2	General Corporate Expenses	0.00	10.00
3	Public Issue Expenses	6.96	33.04
	Total	6.96	197.04

Funds Deployed and Sources of Funds Deployed:

Our Statutory Auditors - M/s. Santlal Patel & Co., Chartered Accountants vide their certificate dated May 21, 2014 have confirmed that as on May 21, 2014, the following funds have been deployed for the proposed object of the Issue:

(₹ In Lakhs)

Sr. No.	Particulars	Amount deployed
1	Issue Expenses	6.96
	Total	6.96

Sources of Financing for the Funds Deployed

Our Statutory Auditors - *M/s. Santlal Patel & Co., Chartered Accountants.*, vide their certificate dated May 21, 2014 have also confirmed the amount deployed so far towards part of the Issue expenses has been financed through internal sources. We would like to replenish these expenses out of the Issue proceeds.

(₹ In Lakhs)

Sr. No.	Particulars	Amount deployed
1	Internal Accruals	6.96
	Total	6.96

Appraisal

None of the Objects have been appraised by any bank or financial institution or any other independent third party organization. The funding requirements of our Company and the deployment of the proceeds of the Issue are currently based on management estimates. The funding requirements of our Company are dependent on a number of factors which may not be in the control of our management, including variations in interest rate structures, changes in our financial condition and current commercial conditions and are subject to change in light of changes in external circumstances or in our financial condition, business or strategy.

Shortfall of Funds

Any shortfall in meeting the cost will be met by way of internal accruals.

Bridge Financing Facilities

As on the date of this Prospectus, we have not raised any bridge loans which are proposed to be repaid from the Net Proceeds.

Monitoring Utilization of Funds

Since the Issue size does not exceed ₹ 50,000 Lacs, the appointment of a monitoring agency as per Regulation 16 of the SEBI Regulations is not required. As required under the listing agreements with the Stock Exchanges, the Audit Committee appointed by our Board will monitor the utilization of the Issue proceeds. We will disclose the utilization of the proceeds of the Issue, including interim use, under a separate head in our quarterly/half yearly financial disclosures and annual audited financial statements until the Issue Proceeds remain unutilized, to the extent required under the applicable law and regulation. We will indicate investments, if any, of unutilized proceeds of the Issue in our Balance Sheet for the relevant Financial Years subsequent to our listing.

The Audit committee & the Board of Directors of our Company will monitor the utilization of funds raised through this public issue. Pursuant to Clause 52 of the SME Listing Agreement, the Audit Committee would be reviewing, with the management, the statement of uses / application of funds raised through this issue and shall be making appropriate recommendations to the Board to take up steps in this matter. On an annual basis, our Company shall prepare a statement of funds utilized for purposes other than stated in this Prospectus and place it before the Audit Committee. Such disclosures shall be made only until such time that all the proceeds of the Issue have been utilized in full. The statement of funds utilized will be certified by the Statutory Auditors of our Company.

Interim Use of Proceeds

Our management, in accordance with the policies established by our Board of Directors, will have flexibility in deploying the proceeds received from the Issue. Pending utilization of the proceeds of the Issue for the purposes described above, we may invest the funds in high quality interest bearing liquid instruments including money market mutual funds, deposits with banks or temporarily deploy the funds in working capital loan accounts and other investment grade interest bearing securities as may be approved by the Board of Directors. Such investments would be in accordance with the investment policies approved by our Board of Directors from time to time and at the prevailing commercial rates at the time of investment.

Other confirmations

There is no material existing or anticipated transactions with our Promoter, our Directors, our Company's key Managerial personnel and Group Entities, in relation to the utilisation of the Net Proceeds. No part of the Net Proceeds will be paid by us as consideration to our Promoter, our Directors or key managerial personnel or our Group Entities, except in the normal course of business and in compliance with the applicable laws.

BASIC TERMS OF THE ISSUE

Authority for the Present Issue

The Issue in terms of the Prospectus has been authorized by the Board of Directors pursuant to a resolution dated January 09, 2014, subject to the approval of shareholders and by the shareholders pursuant to a special resolution in an Extra Ordinary General Meeting held on January 20, 2014 under section 81 & 81(1A) of the Companies Act, 1956.

Terms of the Issue

The Equity Shares, now being offered, are subject to the terms and conditions of this Prospectus, Prospectus, Application form, Confirmation of Allocation Note ("CAN"), the Memorandum and Articles of Association of our Company, the guidelines for listing of securities issued by the Government of India and SEBI (ICDR) Regulations, the Depositories Act, Stock Exchanges, RBI, ROC and/or other authorities as in force on the date of the Issue and to the extent applicable.

In addition, the Equity Shares shall also be subject to such other conditions as may be incorporated in the Share Certificates, as per the SEBI (ICDR) Regulations, 2009, notifications and other regulations for the issue of capital and listing of securities laid down from time to time by the Government of India and/or other authorities and other documents that may be executed in respect of the Equity Shares.

Face Value	Each Equity Share shall have the face value of ₹ 10.00 each.
Issue Price	Each Equity Share is being offered at a price of ₹ 30.00 each and is 3.0 times of Face Value.
Market Lot and Trading Lot	The Market lot and Trading lot for the Equity Share is 4,000 (Four Thousand) and the multiple of 4,000; subject to a minimum allotment of 4,000 Equity Shares to the successful applicants.
Terms of Payment	100% of the issue price of ₹ 30.00 per share shall be payable on Application. For more details please refer to page no. 187 of this Prospectus.
Ranking of the Equity Shares	The Equity Shares shall be subject to the provisions of Memorandum and Articles of Association of the Company and shall rank pari-passu in all respects including dividends with the existing Equity Shares of the Company. The Allottees in receipt of Allotment of Equity Shares under this Issue will be entitled to dividends and other corporate benefits, if any, declared by the Company after the date of Allotment. For further details, please see " Main Provisions of the Articles of Association " on page 201 of this Prospectus.

Minimum Subscription

In accordance with Regulation [106P](1) of SEBI ICDR Regulations, this Issue is 100% underwritten. Also, in accordance with explanation to Regulation [106P](1) of SEBI ICDR Regulations the underwriting shall not be restricted up to the minimum subscription level.

If our Company does not receive subscription of 100% of the Issue including devolvement of Underwriters within 60 (sixty) days from the date of closure of the issue, our Company shall forthwith refund the entire subscription amount received. If there is a delay beyond 8 (eight) days after our Company becomes liable to pay the amount, our Company shall pay interest prescribed under the Companies Act.

Further, In accordance with Regulation [106R] of SEBI ICDR Regulations, No allotment shall be made pursuant to the Issue, if the number of prospective allottees is less than 50 (fifty).

For further details, please refer to section titled "**Terms of the Issue**" beginning on page 174 of this Prospectus.

BASIS FOR ISSUE PRICE

Investors should read the following summary with the section titled "**Risk Factors**", the details about our Company under the section titled "**Our Business**" and its financial statements under the section titled "**Financial Information of the Company**" beginning on pages 11,72 and 113 respectively of this Prospectus. The trading price of the Equity Shares of our Company could decline due to these risks and the investor may lose all or part of his investment.

The Issue Price has been determined by the Company in consultation with the LM on the basis of the key business strengths of our Company. The face value of the Equity Shares is ₹ 10.00 each and the Issue Price is ₹ 30.00 which is 3 times of the face value.

Qualitative Factors

- Experienced Management Team
- Strong Range of Products, Strong Brand
- Quality Assurance and Standards.
- Extensive and Cost beneficial Manufacturing Facility

For a detailed discussion on the qualitative factors which form the basis for computing the price, please refer to sections titled "**Our Business**" and "**Risk Factors**" beginning on pages 72 and 11 respectively of this Prospectus.

Quantitative Factors

Information presented in this section is derived from our Company's restated financial statements prepared in accordance with Indian GAAP. Some of the quantitative factors, which form the basis for computing the price, are as follows:

1. Basic & Diluted Earnings per share (EPS)

Year ended	Basic and Diluted EPS (₹)	Weight
F.Y. 2010-2011	7.13	1
F.Y. 2011-2012	(10.33)	2
F.Y. 2012-2013	36.35	3
Weighted average EPS	15.92	
Nine months period ended December 31, 2013*	3.08	

*Not annualised.

Notes:

1. The figures disclosed above are based on the restated summary statements of our Company.
2. The face value of Equity Share was ₹10.00 each.
3. EPS has been calculated in accordance with Accounting Standard 20 - Earnings per Share issued by the Institute of Chartered Accountants of India.
4. The above statement should be read with Significant Accounting Policies and the Notes to the Restated Summary Statements as appearing in Annexure IV.

2. Price Earnings Ratio (P/E Ratio) in relation to the Issue Price of ₹30.00 per share

Particulars	P/E Ratio
P/E ratio based on the Basic & Diluted EPS for F.Y. 2012-2013	0.83
P/E ratio based on the Weighted Average EPS for F.Y. 2012-2013	1.88

3. Return on Net worth (RoNW)

Year ended	RoNW (%)	Weight
March 31, 2011	18.50	1
March 31, 2012	(84.12)	2
March 31, 2013	39.81	3
Weighted Average RONW (%)	(5.05)	
Nine months period ended December 31, 2013*	16.05	

*Not annualised.

Note:

1. The RoNW has been computed by dividing profit after tax by net worth.

4. Minimum Return on Increased Net Worth Required to Maintain Pre-Issue EPS

(a) Based on Basic and Diluted EPS of 2012-13 at the Issue Price of ₹30.00
– 2.02 % on the Restated Financial Statements.

(b) Based on Weighted Average EPS at the Issue Price of ₹30.00
– 0.88 % on the Restated Financial Statements.

5. Net Asset Value (NAV) per Equity Share (₹) as per our restated financial information

Particulars	NAV per share (₹)
F.Y. 2010-2011	38.53
F.Y. 2011-2012	6.98
F.Y. 2012-2013	16.11
As at Nine months period ended December 31, 2013	19.19
NAV after the Issue	18.02
Issue Price	30.00

Note:

1. Net Asset Value per share represents net worth, as restated, divided by the number of Equity Shares as at year end.

6. Comparison with Industry Peers and Industry average

We are currently engaged in the business of manufacturing of Colour Coated Roof Sheets, FRP Roof Sheets, Polycarbonate Sheets, Turbo Ventilators and other miscellaneous Roofing Accessories. Currently, there is no listed peer group company which are strictly comparable to us with respect to the industry and business segment in which we operate and the size of our company.

7. The face value of our Equity Shares is ₹10.00 and the Issue Price is ₹ 30.00 i.e., 3 times of the face value.

The Issue Price of ₹ 30.00 has been determined by our Company in consultation with the LM, on the basis of the key business strengths of our Company. Investors should read the above mentioned information along with section titled "**Our Business**", "**Risk Factors**" and "**Financial Information of the Company**" beginning on pages 72, 11 and 113 respectively including important profitability and return ratios, as set out in "**Annexure [P]**" on page no. 138 of this Prospectus, to have a more informed view.

STATEMENT OF TAX BENEFITS

To,
The Board of Directors,
Bansal Roofing Products Limited
3/2, Labdhi Industrial Estate,
Acid Mill Compound,
Ranmukteshwar Road, Pratapnagar,
Vadodara – 390004, Gujarat

Dear Sirs,

Sub: Statement of Possible Tax Benefits Available to the Company and its shareholders with regards to Initial Public Offer of Bansal Roofing Products Limited

We hereby report that the enclosed statement provides the possible tax benefits available to the Company and to the shareholders of the Company under the Income tax Act, 1961 (provisions of Finance Act, 2014), and Wealth Tax Act, 1957, presently in force in India. Several of these benefits are dependent on the Company or its shareholders fulfilling the conditions prescribed under the relevant provisions of the statute. Hence, the ability of the Company or its shareholders to derive the tax benefits is dependent upon fulfilling such conditions, which based on the business imperatives, the Company faces in the future, the Company may or may not choose to fulfill.

The benefits discussed in the enclosed statement are not exhaustive. This statement is only intended to provide general information to the investors and is neither designed nor intended to be a substitute for professional tax-advice. In view of the individual nature of the tax consequences and the changing tax laws, each investor is advised to consult his or her own tax consultant with respect to the specific tax implications arising out of their participation in the issue. We do not express any opinion or provide any assurance as to whether:

- (i) Company or its shareholders will continue to obtain these benefits in future; or
- (ii) The conditions prescribed for availing the benefits has been/ would be met with.

The contents of the enclosed statement are based on information, explanations and representations obtained from the Company and on the basis of our understanding of the business activities and operations of the Company.

For Santlal Patel & Co.
Chartered Accountants
Firm Registration No. 113888W

Sd/-
CA. Santlal C. Patel
Proprietor
M. No. 47612
Date: March 29, 2014
Place: Vadodara

STATEMENT OF TAX BENEFITS

The tax benefits listed below are the possible benefits available under the current tax laws in India. Several of these benefits are dependent on the Company or its Shareholders fulfilling the conditions prescribed under the relevant tax laws. Hence, the ability of the Company or its Shareholders to derive the tax benefits is dependent upon fulfilling such conditions, which based on business imperatives it faces in the future, it may not choose to fulfill.

Benefits available under the Income Tax Act, 1961

(i) Special tax benefits

1. Special tax benefits available to the Company

There are no special tax benefits available to the Company.

2. Special tax benefits available to the Shareholders of the Company

There are no special tax benefits available to the shareholders of the Company.

(ii) General tax benefits

The Income Tax Act, 1961 and Wealth Tax Act, 1957 presently in force in India, make available the following general tax benefits to companies and to their shareholders. Several of these benefits are dependent on the companies or their shareholders fulfilling the conditions prescribed under the relevant provisions of the statute.

I. Benefits to the Company under the Income Tax Act, 1961 ("the Act"):

The Company will be entitled to deduction under the sections mentioned hereunder from its total income chargeable to Income Tax.

1. Income by way of interest, premium on redemption or other payment on notified securities, bonds, certificates issued by the Central Government is exempt from tax under section 10(15) of the Income-tax Act, 1961 (herein after referred to as 'the Act') in accordance with and subject to the conditions and limits as may be specified in notifications.
2. As per Section 10(34) of the Act, income earned by the Company by way of dividend income from another domestic company referred to in section 115-O of the act is exempt from tax.
3. As per section 10(35) of the Acts, the following income will be exempt from tax in the hands of the Company:
 - a) Income received in respect of the units of a Mutual Fund specified under section 10(23D) (other than income arising from transfer of such units); or
 - b) Income received in respect of units from the Administrator of the specified undertaking; or
 - c) Income received in respect of units from the specified company:

However, this exemption does not apply to any income arising from transfer of units of the Administrator of the specified undertaking or of the specified company or of a mutual fund, as the case may be.

For this purpose (i), 'Administrator' mean the Administrator as referred to in section 2 (a) of the Unit Trust of India (Transfer of Undertaking and Repeal) Act, 2002 and (ii), 'Specified Company' means a company as referred to in section 2 (h) of the said Act.

4. As per section 10(38) of the Act, long term capital gains arising to the Company from the transfer of a long term capital asset being an equity share in a company or a unit of an equity oriented fund, where such transaction is chargeable to securities transaction tax, will be exempt in the hands of the Company.

For this purpose, 'Equity Oriented Fund' means a fund-

- (i) Where the investible funds are invested by way of equity shares in domestic companies to the extent of more than sixty five percent of the total proceeds of such funds; and
- (ii) Which has been set up under a scheme of Mutual Fund specified under section 10 (23D) of the Act.

Bansal Roofing Products Limited

5. Under section 32 of the Act, the Company is entitled to claim depreciation on tangible and specified intangible assets as explained in the said section and the relevant Income Tax rules there under. In accordance with the subject to the conditions specified in Section 32(1)(ia) of the Act, the Company is entitled to an additional depreciation allowance of 20% of the cost of new machines acquired and put to use during a year.
6. Under Section 35 (1) (ii) and (iii) of the Act, in respect of any sum paid to a scientific research association which has as its object the undertaking of scientific research, or to any approved university, College or other institution to be used for scientific research or for research in social sciences or statistical scientific research to the extent of a sum equal to one and one fourth times the sum so paid.

Subject to authorized of specified conditions, the Company will be eligible, inter alia, for deduction in respect of revenue expenditure under section 35(1)(i) and in respect of capital expenditure (other than expenditure on the acquisition of any land) under section 35(1) (iv) of the Act incurred on scientific research.

As per section 35(2AB) of the Act, the Company will be entitled to claim deduction of 200% of the expenditure incurred on in-house research and development facility subject to authorized of certain conditions specified therein.

7. Under section 36(1) (vii), any bad debt or part thereof written off as irrecoverable in the accounts is allowable as a deduction from the total income.
8. In computing the business income, an amount equal to STT paid in respect of taxable securities transactions entered into in the course of business will be allowed as a deductible expense, if the income arising from such taxable securities transactions is included in the income computed under the head “Profits and Gains of Business or Profession” as per the provisions of section 36(1) (xv) of the Act.
9. As per provisions of Section 48 of the Income Tax Act, Long term Capital Gain arising on transfer of capital assets, other than bonds and debentures (excluding capital indexed bonds issued by the Government) and depreciable assets, is computed by deducting the indexed cost of acquisition and indexed cost of improvement from the full value of consideration.
10. As per section 54EC of the Act and subject to the conditions and to the extent specified therein, long-term capital gains (in cases not covered under section 10(38) of the Act) arising on the transfer of a long-term capital asset will be exempt from tax if the capital gains are invested in a "long term specified asset" within a period of six months after the date of such transfer, subject to the limit of Rupees Fifty Lacs in a year. Where the “long term specified asset” are transferred or converted into money within three years from the date of their acquisition, the amount so exempted is taxable as capital gains in the year of transfer / conversion.
11. Business losses, if any, for an assessment year can be carried forward and set off against business profits for eight subsequent years.
12. Unabsorbed depreciation, if any, for an assessment year can be carried forward and set off against income from any other source in the subsequent assessment years as per section 32(2) subject to the provisions of section 72(2) and section 73(3) of the Act.
13. As per provisions of Section 71 read with Section 74 of the Act, short - term capital loss arising during a year is allowed to be set-off against short - term as well as long - term capital gains. Balance loss, if any, shall be carried forward and set-off against any capital gains arising during subsequent eight assessment years.
14. As per provisions of Section 71 read with Section 74 of the Act, long - term capital loss arising during a year is allowed to be set-off only against long - term capital gains. Balance loss, if any, shall be carried forward and set-off against long – term capital gains arising during subsequent eight assessment years.
15. The Company is entitled to deduction under section 80G of the Act in respect of amounts contributed as donations to various charitable institutions and funds covered under that section, subject to fulfillment of conditions specified therein.
16. As per the provisions of section 90, for taxes on income paid in Foreign Countries with which India has entered into Double Taxation Avoidance Agreements (Tax Treaties from projects/activities undertaken thereat), the Company will be entitled to the deduction from the India Income-tax of a sum calculated on such doubly taxed income to the extent of taxes paid in Foreign Countries. Further, the company as a tax resident of India would be entitled to the benefits of

Bansal Roofing Products Limited

such Tax Treaties in respect of income derived by it in foreign countries. In such cases the provisions of the Income tax Act shall apply to the extent they are more beneficial to the company. Section 91 provides for unilateral relief in respect of taxes paid in foreign countries.

17. As per section 111A of the Act, short term capital gains arising to the Company from the sale of equity shares or units of an equity oriented mutual fund transacted through a recognized stock exchange in India, where such transaction is chargeable to securities transaction tax, will be taxable at the rate of 15% ((plus applicable surcharge plus education cess plus higher education cess) Further, short term gains as computed above that are not liable to STT would be subject to tax at a rate of 30% (plus applicable surcharge plus education cess plus higher education cess) in case of a company.
18. In accordance with section 112 of the Act, long-term capital gains to the extent not exempt under Section 10(38) of the Act would be subject to tax at the rate of 20% (plus applicable surcharge plus education cess plus higher education cess with indexation benefits. However, as per the proviso to Section 112 of the Act, if the tax on long-term capital gains is resulting from transfer of listed securities or units or zero coupon bonds, then long term capital gain will be chargeable to tax at the rate lower of the following: -
 - 20% (plus applicable surcharge plus education cess plus higher education cess of the capital gains as computed after indexation of the cost; or
 - 10% (plus applicable surcharge plus education cess plus higher education cess) of the capital gains as computed without indexation.
19. As per provisions of section 115JB of the Act, the Company will be required to pay Minimum Alternate Tax ("MAT") at the prevailing rate as provided by the applicable Finance Act on the book profit determined, if the income-tax payable as per normal provisions of the Act is less than such amount. If the Company has paid taxes under section 115JB of the Act.
According to provisions of section 115JAA, the amount paid will be available as MAT credit to the Company for setting off against normal taxes in succeeding ten years subject to fulfillment of certain conditions prescribed in the said section.

II. Benefits to the Members / Shareholders

A. Resident Members / Shareholders

1. Under Section 10(32) of the Act, any income of minor children clubbed in the total income of the parent under section 64(1A) of the Act will be exempted from tax to the extent of ₹1,500/- per minor child.
2. As per section 10(34) of the Act, income earned by the resident member by way of dividend income from the domestic company referred to in section 115-O of the act is exempt from tax.
3. As per section 10(38) of the Act, long term capital gains arising to the resident member from the transfer of a long term capital asset being an equity share in a company or a unit of an equity oriented fund, where such transaction is chargeable to securities transaction tax, will be exempt in the hands of such members. However, in case the shareholder is a Company, income by way of long term capital gain shall not be reduced in computing the book profits for the purposes of computation of minimum alternate tax ("MAT") under section 115JB of the I.T. Act.
4. Under section 36(1)(xv) of the Act, Securities Transaction Tax paid by a Shareholder in respect of taxable securities transactions entered into in the course of its business, would be allowed as a deduction if the income arising from such taxable securities transactions is included in the income computed under the head —Profits and Gains of Business or Profession.
5. As per provisions of Section 48 of the Income Tax Act, Long term Capital Gain arising on transfer of capital assets, other than bonds and debentures (excluding capital indexed bonds issued by the Government) and depreciable assets, is computed by deducting the indexed cost of acquisition and indexed cost of improvement from the full value of consideration.
6. Under Section 54EC of the Income Tax Act, 1961 and subject to the conditions and to the extent specified therein, long term capital gains arising on the transfer of shares of the Company will be exempt from capital gains tax if the capital gains are invested up to ₹ 50 lacs within a period of 6 months from the date of transfer in the bonds issued by
 - National Highways Authority of India constituted under section 3 of National Highways Authority of India Act, 1988;

- Rural Electrification Corporation Limited, a Company formed and registered under the Companies Act, 1956;
7. In accordance with section 54F, Long-Term Capital Gains arising on the transfer of the shares of the Company held by an individual and Hindu Undivided Family on which Securities Transaction Tax is not payable, shall be exempt from Capital Gains Tax, if the net consideration is utilized, within a period of one year before, or two years after the date of transfer, in the purchase of a new residential house, or for construction of a residential house within three years. Such benefit will not be available if the individual-
 - owns more than one residential house, other than the new residential house, on the date of transfer of the shares; or
 - purchases another residential house within a period of one year after the date of transfer of the shares; or
 - constructs another residential house within a period of three years after the date of transfer of the shares; and
 - the income from such residential house, other than the one residential house owned on the date of transfer of the original asset, is chargeable under the head “Income from house property”.
 8. As per provisions of Section 56(2)(vii) of the Income Tax Act and subject to exception provided in second proviso therein, where an individual or a HUF receives shares and securities without consideration or for a consideration which is less than the aggregate fair market value (as defined) of the shares and securities by an amount exceeding ₹ 50,000, the excess of fair market value of such shares and securities over the said consideration is chargeable to tax under the head ‘income from other sources’.
 9. As per provisions of Section 71 read with Section 74 of the Act, short - term capital loss arising during a year is allowed to be set-off against short - term as well as long - term capital gains. Balance loss, if any, shall be carried forward and set-off against any capital gains arising during subsequent eight assessment years.
 10. As per provisions of Section 71 read with Section 74 of the Act, long - term capital loss arising during a year is allowed to be set-off only against long - term capital gains. Balance loss, if any, shall be carried forward and set-off against long – term capital gains arising during subsequent eight assessment years.
 11. As per section 111A of the Act, short term capital gains arising to the resident members from the sale of equity shares or units of an equity oriented mutual fund transacted through a recognized stock exchange in India, where such transaction is chargeable to securities transaction tax, will be taxable at the rate of 15% (plus applicable surcharge plus education cess plus higher education cess). Further, short term gains as computed above that are not liable to STT would be subject to tax at a rate of 30% (plus applicable surcharge plus education cess plus higher education cess) in case the shareholder is a company and it would be taxable at their normal tax rates in case the shareholder is other than a company.
 12. In accordance with section 112 of the Act, long-term capital gains to the extent not exempt under Section 10(38) of the Act would be subject to tax at the rate of 20% (plus applicable surcharge plus education cess plus higher education cess) with indexation benefits. However, as per the proviso to Section 112 of the Act, if the tax on long-term capital gains is resulting from transfer of listed securities or units or zero coupon bonds, then long term capital gain will be chargeable to tax at the rate lower of the following: -
 - 20% (plus applicable surcharge plus education cess plus higher education cess) of the capital gains as computed after indexation of the cost; or
 - 10% (plus applicable surcharge plus education cess plus higher education cess) of the capital gains as computed without indexation.

B. Non-Resident Indian Members / Shareholders or Non-Resident Members / Shareholders (other than FIIs and Foreign Venture Capital Investors):

1. As per section 10(34) of the Act, income earned by way of dividend income from the domestic company referred to in section 115-O of the act is exempt from tax.
2. As per section 10(38) of the Act, long term capital gains arising from the transfer of a long term capital asset being an equity share in a company or a unit of an' equity oriented fund, where such transaction is chargeable to securities transaction tax, will be exempt. However, in case the shareholder is a Company, income by way of long term capital gain shall not be reduced in computing the book profits for the purposes of computation of minimum alternate tax ("MAT") under section 115JB of the I.T. Act.
3. Under Section 36 (1) (xv) of the Act, the amount of Securities Transaction Tax paid by an assessee in respect of taxable securities transactions offered to tax as "Profits and gains of Business or profession" shall be allowable as a deduction against such Business Income.
4. As per the first proviso to section 48 of the Act, in case of a non resident shareholder, the capital gain/loss arising from transfer of shares of the Company, acquired in convertible foreign exchange, will be computed by converting the cost of acquisition, sales consideration and expenditure incurred wholly and exclusively incurred in connection with such transfer, into the same foreign currency which was initially utilized in the purchase of shares. Cost indexation benefit will not be available in such a case.
5. As per section 54EC of the Act and subject to the conditions and to the extent specified therein, long-term capital gains (in cases not covered under section 10(38) of the Act) arising on the transfer of a. long-term capital asset will be exempt from tax if the capital gains are invested in a "long term specified asset" within a period of six months after the date of such transfer, subject to the limit of Rupees Fifty Lacs in a year. Where the "long term specified asset" are transferred or converted into money within three years from the date of their acquisition, the amount so exempted is taxable as capital gains in the year of transfer / conversion.
6. As per the provisions of section 54F of the Act, long term capital gains (in cases not covered under section 10(38) and subject to the condition specified therein arising on the transfer of the shares of the Company held by an individual or Hindu Undivided Family will be exempt from tax if the net consideration is utilized, within a period of one year before, or two years after the date of transfer, in the purchase of a residential house, or for construction of a residential house within three years from the date of transfer.
7. As per provisions of Section 56(2)(vii) of the Income Tax Act and subject to exception provided in second proviso therein, where an individual or a HUF (if applicable) receives shares and securities without consideration or for a consideration which is less than the aggregate fair market value (as defined) of the shares and securities by an amount exceeding ₹ 50,000, the excess of fair market value of such shares and securities over the said consideration is chargeable to tax under the head 'income from other sources'.
8. As per provisions of Section 71 read with Section 74 of the Act, short - term capital loss arising during a year is allowed to be set-off against short - term as well as long - term capital gains. Balance loss, if any, shall be carried forward and set-off against any capital gains arising during subsequent eight assessment years.
9. As per provisions of Section 71 read with Section 74 of the Act, long - term capital loss arising during a year is allowed to be set-off only against long - term capital gains. Balance loss, if any, shall be carried forward and set-off against long – term capital gains arising during subsequent eight assessment years.
10. As per section 111A of the Act, short term capital gains arising from the sale of equity shares or units of an equity oriented mutual fund transacted through a recognized stock exchange in India, where such transaction is chargeable to securities transaction tax, will be taxable at the rate of 15% (plus applicable surcharge plus education cess plus higher education cess. Further, short term gains as computed above that are not liable to STT arising to non-resident shareholders would be subject to tax at their normal tax rates (plus applicable surcharge plus education cess plus higher education cess).

11. In accordance with section 112 of the Act, long-term capital gains to the extent not exempt under Section 10(38) of the Act would be subject to tax at the rate of 20% (plus applicable surcharge plus education cess plus higher education cess) with indexation benefits. However, as per the proviso to Section 112 of the Act, if the tax on long-term capital gains is resulting from transfer of listed securities or units or zero coupon bonds, then long term capital gain will be chargeable to tax at the rate lower of the following: -
 - 20% (plus applicable surcharge plus education cess plus higher education cess) of the capital gains as computed after indexation of the cost; or
 - 10% (plus applicable surcharge plus education cess plus higher education cess) of the capital gains as computed without indexation.
12. Under the provisions of Section 195 of the Income Tax Act, any income (not being an income chargeable under the head 'Salaries'), payable to non residents, is subject to withholding tax as per the prescribed rate in force, subject to the tax treaty. Accordingly income tax may have to be deducted at source in the case of a non-resident at the rate under the domestic tax laws or under the tax treaty, whichever is beneficial to the assessee unless a lower withholding tax certificate is obtained from the tax authorities.
13. The tax rates and consequent taxation mentioned above will be further subject to any benefits available under the Tax Treaty, if any, between India and the country in which the non-resident has fiscal domicile. As per the provisions of section 90(2) of the Act, the provisions of the Act would prevail over the provisions of the Tax Treaty to the extent they are more beneficial to the nonresident.

Special provision in respect of Income / LTCG from Specified Foreign Exchange Assets available to Non- Resident Indians (NRI) under Chapter XII-A of the Income Tax Act

14. In accordance with section 115E, income from investment or income from long- term capital gains on transfer of assets other than specified asset shall be taxable at the rate of 20% ((plus applicable surcharge plus education cess plus higher education cess). Income by way of long term capital gains in respect of a specified asset (as defined in section 115C (f) of the act), shall be chargeable at 10% (plus applicable surcharge plus education cess plus higher education cess).
15. In accordance with section 115F, subject to the conditions and to the extent specified therein, long- term capital gain arising from transfer of shares of the company acquired out of convertible foreign exchange, and on which securities transaction tax is not payable, shall be exempt from capital gains tax, if the net consideration is invested within six months of the date of transfer in any specified asset or in any saving certificates referred to in clause (4B) of section 10 of the Income-Tax Act.
16. In accordance with section 115G, it is not necessary for a Non resident Indian to file a return of income under section 139(1), if his total income consists only of investment income earned on shares of the company acquired out of convertible foreign exchange or income by way of long term capital gains earned on transfer of shares of the company acquired out of convertible foreign exchange, and the tax has been deducted at source from such income under the provisions of Chapter XVII-B of the Income-tax Act.
17. In accordance with section 115I, where a Non Resident Indian opts not to be governed by the provision of chapter XII-A for any assessment year, his total income for that assessment year (including income arising from investment in the company) will be computed and tax will be charged according to the other provisions of the Income-tax Act.
18. As per section 115H of the Act, where a non-resident Indian becomes assessable as a resident in India, he may furnish a declaration in writing to the Assessing Officer, along with his return of income for that year under section 139 of the Act to the effect that the provisions of Chapter XII-A shall continue to apply to him in relation to such investment income derived from the specified assets for that year and subsequent assessment years until such assets are converted into money.

C. Foreign Institutional Investors (FII's)

1. As per section 10(34) of the Act, income earned by way of dividend income from the domestic company referred to in section 115-O of the act is exempt from tax.

Bansal Roofing Products Limited

2. As per section 10(38) of the Act, long term capital gains arising from the transfer of a long term capital asset being an equity share in a company or a unit of an equity oriented fund, where such transaction is chargeable to securities transaction tax, will be exempt.
3. As per provisions of Section 115AD of the Act, income (other than income by way of dividends referred to Section 115-O) received in respect of securities (other than units referred to in Section 115AB) is taxable at the rate of 20% (plus applicable surcharge plus education cess plus higher education cess).
4. As per section 115 AD read with section 111A of the Act, short term capital gains arising from the sale of equity shares of the Company transacted through a recognized stock exchange in India, where such transaction is chargeable to securities transaction tax, will be taxable at the rate of 15% (plus applicable surcharge plus education cess plus higher education cess).
5. As per section 115AD of the Act, FIIs will be taxed on the capital gains that are not exempt under the provisions of section 10(38) of the Act at the following rates:

Nature of Income	Rate of tax (%)*
a) Long term capital gains	10
b) Short term capital gains (other than referred to in section 111A)	30

*(plus applicable surcharge plus education cess plus higher education cess)

6. In case of long term capital gains, (in cases not covered under section 10(38) of the Act), the tax is levied on the capital gains computed without considering the cost indexation and without considering foreign exchange fluctuation.
7. The tax rates and consequent taxation mentioned above will be further subject to any benefits available under the Tax Treaty, if any between India and the country in which the FII has fiscal domicile. As per the provisions of section 90(2) of the Act, the provisions of the Act would prevail over the provisions of the Tax Treaty to the extent they are more beneficial to the FII.

D. Benefits available to Mutual Funds

As per the provisions of section 10(23D) of the Act, any income of Mutual Funds registered under the Securities and Exchange Board of India Act, 1992 or regulations made there under, Mutual Funds set up by public sector banks or public financial institutions or authorized by the Reserve Bank of India, would be exempt from income tax subject to the conditions as the Central Government may notify. However, the mutual funds shall be liable to pay tax on distributed income to unit holders under section 115 R of the act.

E. Benefits available to Venture Capital Companies/ Funds

As per the provisions of section 10(23FB) of the Act, any income of Venture Capital Companies / Funds (set up to raise funds for investment in a venture capital undertaking registered and notified in this behalf) registered with the Securities and Exchange Board of India, would be exempt from income tax, subject to the conditions specified therein. However, the exemption is restricted to the Venture Capital Company and Venture Capital Fund set up to raise funds for investment in a Venture Capital Undertaking, which is engaged in the business as specified under section 10(23FB)(c). However, the income distributed by the Venture Capital Companies/ Funds to its investors would be taxable in the hands of the recipients.

F. Benefits available under the Wealth Tax Act, 1957

Shares of the company held by the shareholder will not be treated as an asset within the meaning of section 2(ea) of Wealth Tax Act, 1957. Hence, no wealth tax will be payable on the market value of shares of the company held by the shareholder of the company.

G. Tax Treaty Benefits

An investor has an option to be governed by the provisions of the Income Tax Act, 1967 or the provisions of a Tax Treaty that India has entered into with another country of which the investor is a tax resident, whichever is more beneficial.

Notes:

- i) In the above statement only basic tax rates have been enumerated and the same is subject to applicable surcharge plus education cess plus higher education cess , wherever applicable.
- ii) The above Statement of Possible Direct Tax Benefits sets out the provisions of law in a summary manner only and is not a complete analysis or listing of all potential tax consequences of the purchase, ownership and disposal of equity shares.
- iii) All the above benefits are as per the current tax laws (including amendments made by the Finance Act 2012), legislation, its judicial interpretation and the policies of the regulatory authorities are subject to change from time to time, and these may have a bearing on the benefits listed above. Accordingly, any change or amendment in the law or relevant regulations would necessitate a review of the above.
- iv) Several of these benefits are dependent on the company and its shareholders fulfilling the conditions prescribed under the provisions of the relevant sections under the relevant tax laws.
- v) This statement is only extended to provide general information to the investors and is neither designed nor intended to be a substitute for Professional Tax Advice. In view of the individual nature of tax consequences, being based on all the facts, in totality, of the investors, each investor is advised to consult his/her/its own tax advisor with respect to specific tax consequences of his/her/its investments in the shares of the Company.
- vi) In respect of non-residents, the tax rates and the consequent taxation mentioned above shall be further subject to any benefits available under the Double Taxation Avoidance Agreement, if any, between India and the country in which the non-resident has fiscal domicile; and
- vii) The stated benefits will be available only to the sole/ first named holder in case the shares are held by joint shareholders.

SECTION IV: ABOUT THE ISSUER COMPANY**INDUSTRY OVERVIEW**

The information in this section has been extracted from various websites and publicly available documents from various industry sources. The data may have been re-classified by us for the purpose of presentation. Neither we nor any other person connected with the Issue has independently verified the information provided in this section. Industry sources and publications, referred to in this section, generally state that the information contained therein has been obtained from sources generally believed to be reliable but their accuracy, completeness and underlying assumptions are not guaranteed and their reliability cannot be assured, and, accordingly, investment decisions should not be based on such information.

India with a GDP of US\$ 1.758 trillion (2013 estimated), is, according to the CIA Factbook, the world's 4th largest economy in Purchasing Power Parity (PPP) terms (the GDP for 2013 in PPP terms is estimated at approximately US\$4.962trillion). Per-capita GDP, in turn, is estimated at US\$4,000 in 2013 in PPP terms. India is now one of the fastest growing economies in the world. According to the CIA Factbook, India's real GDP growth rate was 4.70% in 2013(est.) (Source: Central Intelligence Agency, World Factbook - India, updated on May 9, 2014)

Overview of Indian Economy**Economic Growth**

- 1.1 The Indian economy recovered in the second quarter (Q2) of 2013-14 recording a growth of 4.8 per cent. This follows a growth rate of 4.4 per cent in the first quarter (Q1) of the current financial year— the lowest in 16 quarters. Particularly encouraging is the fact that the recovery in Q2 is noticed on the face of significant fiscal consolidation by the Government and tighter liquidity conditions to moderate aggregate demand. The economy went through challenging times since the crisis in the Euro area in 2011-12 with a cyclical down turn with growth slowdown, elevated current account deficit, persistent inflation, and the need to restore fiscal policy to a sustainable path. While the Government delivered on the announced fiscal targets in 2012-13, current account deficit (CAD) continued to remain elevated in Q1 of 2013-14 and in tandem with market misperception of an imminence of the rollback of quantitative easing in US, assumed a serious dimension with the sharp depreciation of the rupee. The Government put in place a series of measures and there has been a significant let-up in the challenges on the trade and balance of payments front, particularly in the Q2 2013-14. Domestic impediments like elevated levels of food and retail inflation, high input costs and pressure on profit margins and infrastructural bottlenecks continued, with the Government addressing them through appropriate calibration of fiscal policy, administrative measures and institutional mechanisms like Cabinet Committee on Investment to fast track projects.
- 1.2 The recovery in growth, although weak, is expected to gather pace in the coming quarters. Broadly summarised, the indications to this effect are a sharp moderation in CAD composed of both a moderation in imports and pickup in exports; a moderation on year-on-year WPI inflation in the first half over that in the previous year; fiscal consolidation that is broadly on track; and accelerated growth in agriculture and a mild recovery in manufacturing. While there are some concerns about renewed price pressure in October 2013 and the services sector, the driver of growth, is still to pick up, there are indications to the effect that these could be reversed going forward. The analyses in various sections of this chapter would provide the analytical basis for the above assessment. With recent improvements in growth of some sectors, better performance of exports and measures taken by the Government, the year 2013-14 can be expected to end with a growth of 5 per cent.
- 1.3 The Indian economy weathered the global financial crisis rather well and quickly recovered from the decline in growth rate in 2008-09 to a healthy growth that averaged around 9 per cent annually in 2009-10 and 2010-11. However, this recovery was short-lived and growth rate declined to 6.2 per cent in 2011-12 and 5.0 per cent in 2012-13, on account of both domestic and external factors. Despite some recovery in the growth of agriculture and industry sector, particularly in Q2 of the current financial year, the overall growth of the economy has been a modest 4.6 per cent in the first half of the year. The growth rate of the economy improved from 4.4 per cent in Q1 2013- 14 to 4.8 per cent in Q2. Compared to Q1 2013-14, Q2 has evidenced a robust pick-up in the growth of the agricultural sector and a gradual recovery in the industrial sector. The growth in economic services also got strengthened, while the community, social and personal services- a sector with substantial public sector presence - exhibited a significant fall in growth, pointing towards efforts at fiscal consolidation. The demand side impetus to growth is gradually gaining momentum with the strengthening of private consumption and investment and with exports making an impressive turnaround in Q2 2013-14. The confluence of these factors has resulted in a growth of 4.6 per cent during the first half (H1) of 2013-14, roughly the same level of 4.7 per cent achieved during the second half (H2) of 2012-13.

- 1.4 On the external front, the crisis of 2008, the subsequent sovereign debt crisis and the recession in the Euro-area had moderated the average growth rate of the global economy to less than 3 per cent over the period 2008-2012 as compared to 5 per cent during 2004-2007. Data from IMF indicate that several emerging market economies including China and India quickly rebounded to high growth in the aftermath of the crisis. In fact, in terms of market price GDP, India's growth exceeded that of China in 2010. Apart from emerging economies, advanced economies also experienced significant recovery in 2010 with both the US and the Euro-area registered distinctly higher growth rates. A series of subsequent events, including the uncertainty surrounding Euro-area sovereign debt crisis, hampered sustained economic recovery in advanced economies with adverse consequences for growth and challenges for macroeconomic management in emerging market economies. With the intensification of the sovereign debt crisis, the decline in real GDP growth rates starting 2011 has been witnessed across advanced and emerging market economies. Economic growth has again started looking up in advanced economies, especially in the US, alleviating the external constraint on India's recovery to some extent.
- 1.5 The slowdown in real GDP growth in India during 2011-12 and 2012-13 is in sync with trends in similar emerging economies. The downturn has been more pronounced in the Indian case, owing to domestic and structural factors. The growth of real GDP has generally shown a declining trend since the first quarter of 2011-12. An upward movement in some of the quarters in between raised the hope for a turnaround that was belied (Figure 1.1, Panel I). Corresponding to this, the industrial sector witnessed a long, steep decline. The service sector also witnessed growth moderation, which has been gradual and less steep than the industrial sector, and its growth remained more or less constant during Q3 2012-13 to Q1 2013-14. As panel 1 of Figure 1.1 shows, the declining trend in GDP growth has reversed in Q2 2013-14, on the back of higher growth in agriculture and industry vis-à-vis Q1 2013-14.

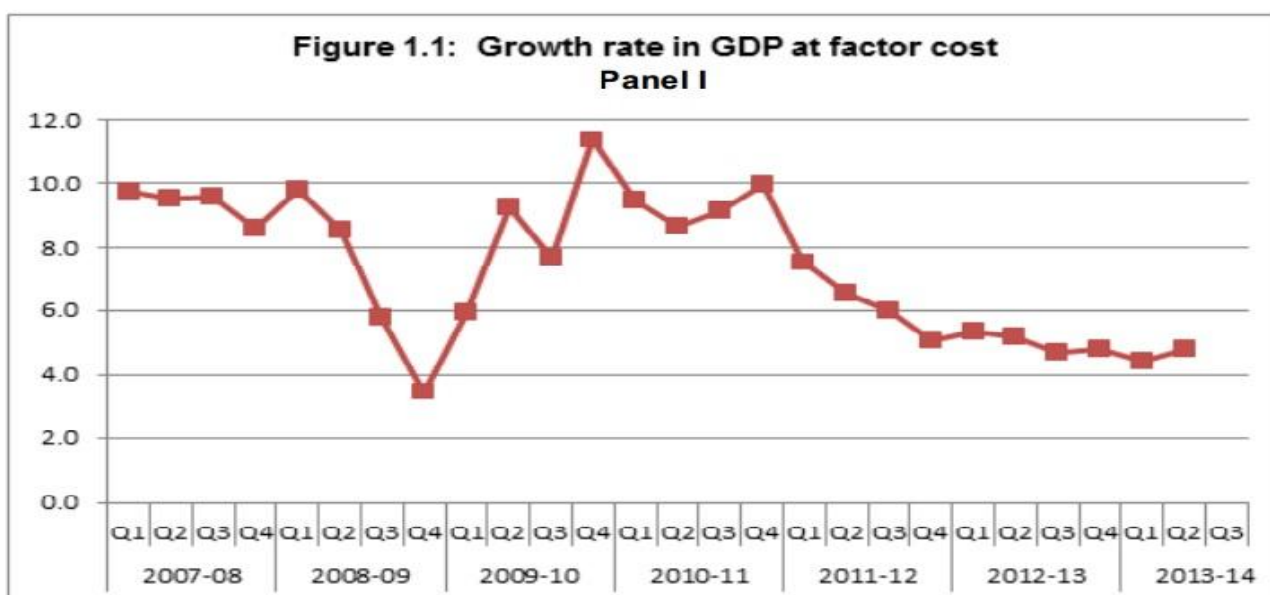

(Source: Mid-Year Economic Analysis, 2013-2014 by Ministry of Finance Department of Economic Affairs Economic Division)

Economic Growth of Indian Industrial Production

Overall growth in the Index of Industrial Production (IIP) was (-) 1.9 per cent during February 2014 vis-à-vis 0.6 per cent in February 2013. During April- February 2013-14, IIP growth was (-) 0.1 per cent as compared to 0.9 per cent in April-February 2012-13.

Percentage Change in Index of Industrial Production				
Industry Group	April-February 2012-13	April-February 2012-13	February 2013	February 2014
General index	0.9	-0.1	0.6	-1.9
Mining	-2.3	-1.1	-7.7	1.4
Manufacturing	1.0	-0.7	2.1	-3.7
Electricity	4.0	6.2	-3.2	11.5

Bansal Roofing Products Limited

Basic goods	2.4	1.7	-1.8	3.9
Capital goods	-7.7	-2.5	9.1	-17.4
Intermediate goods	1.5	3.2	-0.8	4.2
Consumer goods	2.5	-2.8	0.8	-4.5
Durables	2.7	-12.2	-2.6	-9.3
Non-durables	2.3	4.8	3.2	-1.2

Eight core infrastructure industries registered a growth of 4.5 per cent in February 2014 as compared to 1.3 per cent in February 2013. During April- February 2013-14, these sectors grew by 2.6 per cent as compared to 6.4 per cent during April- February 2012-13.

Production growth (per cent) in core infrastructure-supportive industries				
Industry	April-February 2012-13	April-February 2012-13	February 2013	February 2014
Coal	5.0	0.9	-6.1	0.1
Crude Oil	-0.7	-0.1	-4.0	1.9
Natural Gas	-14.2	-13.3	-20.1	-4.4
Refinery Products	29.4	1.6	22.9	3.2
Fertilizers	-4.0	2.2	-4.0	-0.7
Steel	3.4	4.2	4.7	4.8
Cement	7.6	3.3	3.1	2.3
Electricity	4.1	5.7	-3.7	10.4
Overall growth	6.4	2.6	1.3	4.5

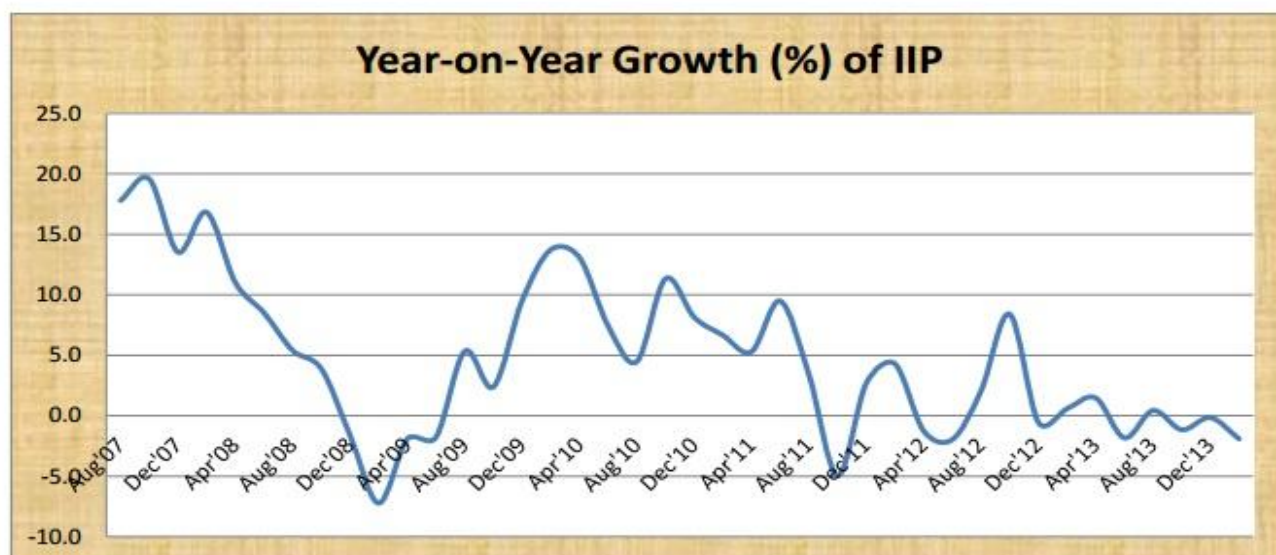

(Source: Monthly Economic Report, March 2014, Ministry of Finance, Department of Economic Affairs, Economic Division, 4(3)/Ec. Dn. /2012)

Steel Industry

Introduction

Steel is one of the most widely used metals in the world. It forms a key constituent of all major economies. Accordingly, the growth in steel consumption is a function of the growth pattern of its various end-use sectors viz. manufacturing, infrastructure, automobile, housing etc. which ultimately guide the country's economy.

India has become the second best in terms of growth amongst the top ten steel producing countries in the world and a net exporter of steel during 2013-14. Steel production in India recorded a growth rate of 4.8 per cent in February 2014 over February 2013. The cumulative growth during April-February, 2013-14 stood at 4.2 per cent over the corresponding period of the previous year. Steel contributes to nearly two per cent of the gross domestic product (GDP) and employs over

Bansal Roofing Products Limited

500,000 people. The total market value of the Indian steel sector stood at US\$ 57.8 billion in 2011 and is expected to touch US\$ 95.3 billion by 2016. The infrastructure sector is India’s largest steel consumer, thereby attracting investments from several global players. Owing to this connection with core infrastructure segments of the economy, the steel industry is of high priority right now. Also, steel demand is derived from other sectors like automobiles, consumer durables and infrastructure; therefore, its fortune is dependent on the growth of these user industries.

(Source: <http://www.ibef.org/industry/steel.aspx> last visited on May 23, 2014)

The liberalisation of the industrial policy and other government initiatives have given a definite impetus for entry, participation and growth of the private sector in the steel industry. Allowing foreign direct investment (FDI) has been a positive step since India is heavily dependent on foreign technologies. These foreign technologies generally add life to the plant and production units, which ultimately lead to the country’s economic growth.

(Source: <http://www.ibef.org/industry/steel.aspx> last visited on May 23, 2014)

Types of Steel

Steel is an iron based mixture containing two or more metallic and/or non metallic elements usually dissolving into each other when molten. Since it is an iron based alloy—as per its end use requirements—other than iron it may contain one or more other elements such as carbon, manganese, silicon, nickel, lead, copper, chromium, etc. For example, stainless steel (a type of steel) mainly contains chromium that is normally more than 10.5 percent with/without nickel or other alloying elements. Steel is produced using Steel Melting Shop that includes converter, open hearth furnace, electric arc furnace and electric induction furnace. There are broadly two types of steel according to its composition: alloy steel and non-alloy steel. Alloying steel is produced using alloying elements like manganese, silicon, nickel, chromium, etc. Non-alloy steel has no alloying component in it except that are normally present such as carbon. Non-alloy steel is mainly of three types viz. mild steel (contains upto 0.3% carbon), medium steel (contains between 0.3-0.6% carbon) and high steel (contains more than 0.6% carbon). All types of steel other than mild steel are called special steel. It is mainly because a special care is taken in order to maintain particular level of chemical composition in such steel. This process gives different properties to the steel according to its composition. In India, non-alloying steel constitutes about 95 percent of total finished steel production, and mild steel has large share in it.

According to shape/size/form steel is categorized into different types such as liquid steel, ingots, semis (semi-finished steel) and finished steel. Liquid steel is a first product that comes out from Steel Melting Shop. Liquid steel further goes into ingots, and then ingots advance to semis. Semis are called semi-finished steel products because they are further subject to forging/rolling in order to produce finish steel products such as flat steel products and long steel products. Crude steel generally includes ingots and semis. According to end use, steel is categorized into structural steels, construction steel, deep drawing Steel, forging quality, rail steel, etc. The following chart depicts various types of steel products according to different categories.

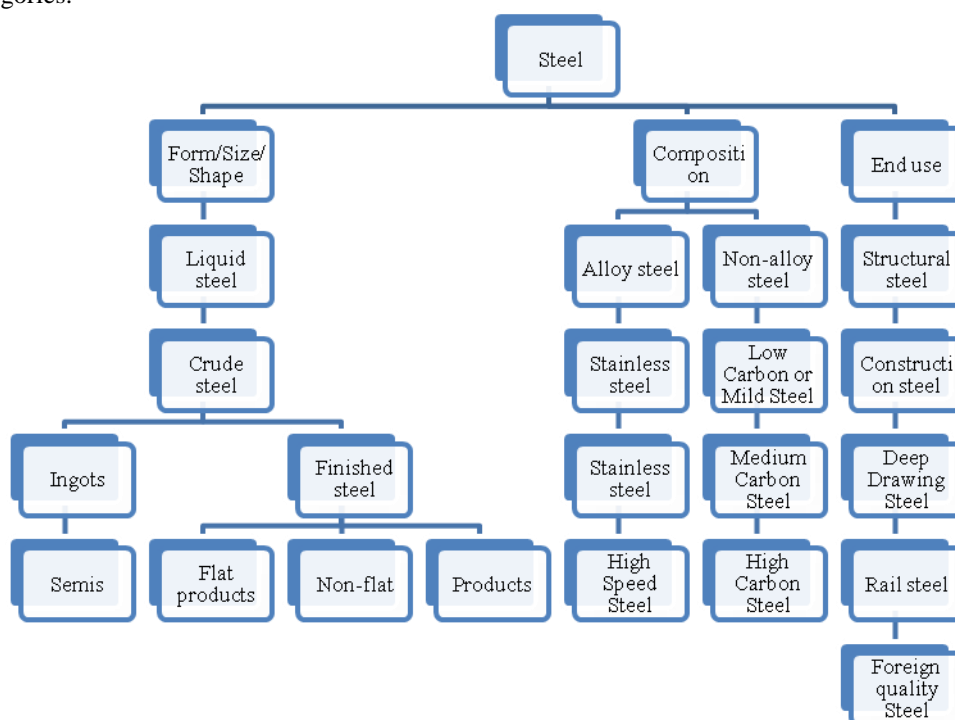

Market Size

India’s real consumption of total finished steel grew by 0.6 per cent year-on-year in April–March 2013-14 to 73.93 million tonnes (MT), according to Joint Plant Committee (JPC), Ministry of Steel. Construction sector accounts for around 60 per cent of the country’s total steel demand while the automobile industry consumes 15 per cent.

India became net steel exporter in 2013–14 and is likely to maintain the momentum in 2014-15 as producers are looking to dock more overseas shipment to tide over subdued domestic consumption. Total steel exports by India during 2013–14 stood at 5.59 MT, as against imports of 5.44 MT. During the period, Steel Authority of India (SAIL) clocked a 30 per cent growth in exports and aims to more than double the shipments to 1 MT in 2014–15. Rashtriya Ispat Nigam Ltd (RINL), which exported 1 lakh tonne steel last fiscal, aims to treble that in the current fiscal.

Iron ore export from India has showed a 253 per cent increase during the period October–December 2013, at 3.75 MT as against 1.06 MT in the corresponding period of the previous year, on the back of the opening of new mines in Chhattisgarh, Madhya Pradesh and Rajasthan, as per the Federation of Indian Mineral Industries (FIMI).

Market Size

In 2011, the Indian steel sector’s total market value was US\$ 57.8 billion.



Consumption

Infrastructure is India’s largest steel consumer, accounting for 63 per cent of total consumption in FY11.

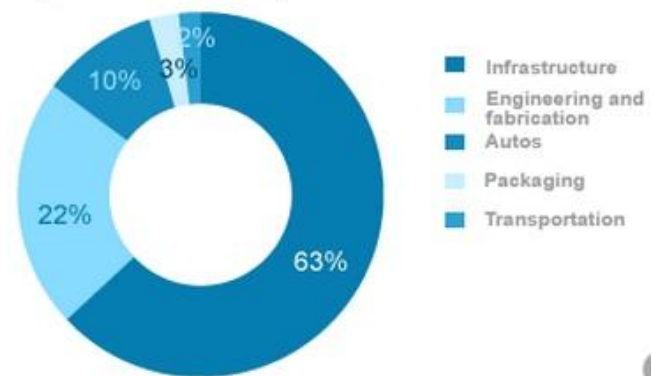

Market Value

India’s metals and mining industry recorded a strong 19.8 per cent expansion in 2011 to touch US\$ 141.9 billion.



Production

India is the world’s fourth-largest producer of coal and has the fifth-largest reserves globally.

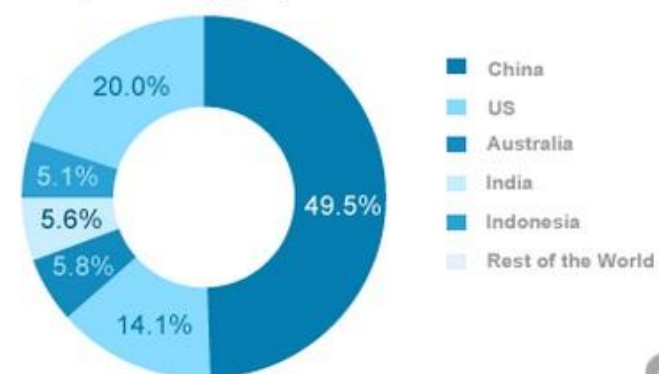

(Source: <http://www.ibef.org/industry/steel.aspx> last visited on May 23, 2014)

Investments

India needs investment of US\$ 210 billion over the next decade to achieve the steel production capacity of 300 million tonnes per annum (MTPA) by 2025 from the current 90 MT, according to Mr C S Varma, Chairman and Managing Director, SAIL. Some of the major investments in the sector are as follows:

- India's third-largest steel maker, JSW Steel, plans to purchase Welspun Maxsteel for about ₹ 1,000 crore (US\$ 165.32 million). The acquisition will help JSW secure continuous supply of cheaper raw material as it plans to expand its capacity at Dolvi, Maharashtra, to 5 MT to supply in the western and northern markets.
- Prize Petroleum, a wholly-owned subsidiary of Hindustan Petroleum Corporation Ltd (HPCL), has acquired stakes in two Australian hydrocarbon fields for A\$ 85 million (US\$ 79.27 million). The company has entered into an agreement with Sydney-based AWE Ltd to acquire 11.25 per cent stake in T/L1 area and 9.75 per cent interest in T/18P area.
- McNally Bharat Engineering Co Ltd has entered Russia for the first time through a subsidiary, MBE Coal & Minerals Technologies GMBH. It received an order worth €5.95 million (US\$ 8.21 million) from Eurochem Group of Russia for an iron ore mining project.
- Canada has invited Coal India Ltd (CIL) to explore mining opportunities in British Columbia, Canada. Mr Stewart Beck, Canadian High Commissioner met with Mr N Kumar, Director (Technical) of Coal India Ltd, to seek investments for coal assets in the Canadian province. CIL currently holds interests in two assets in Mozambique acquired through a concession agreement between the African and Indian governments.

(Source: <http://www.ibef.org/industry/steel.aspx> last visited on May 23, 2014)

Government Initiatives

The Government of India has allowed 100 per cent FDI through the automatic route in the Indian steel sector. It has significantly reduced the duty payable on finished steel products and has streamlined the associated approval process.

The government is taking steps to increase industrial activity in Uttar Pradesh (UP). Addressing a Conference on 'Demand for Steel in India: The End User Perspective,' the Union Minister of Steel, Mr Beni Prasad Verma said, in order to increase supply of steel to rural consumers, companies like SAIL and RINL have set up 521 and more than 100 rural dealers respectively in remote parts of UP.

In order to provide thrust on research and development (R&D), the Ministry of Steel is encouraging R&D activities both in public and private steel sectors, by providing financial assistance from Steel Development Fund (SDF) and Plan Scheme of the Central Government. Under the SDF scheme, 82 R&D projects have been approved with total project cost of ₹ 677 crore (US\$ 111.92 million) wherein SDF assistance is ₹ 370 crore (US\$ 61.17 million). Under the Plan Scheme, eight projects were approved with a total cost of ₹ 123.27 crore (US\$ 20.38 million) wherein Government assistance is ₹ 87.28 crore (US\$ 14.43 million).

To encourage beneficiation and pelletisation of iron ore fines in the country, basic customs duty on the plants and equipment required for initial setting up or substantial expansion of iron ore pellets plants and iron ore beneficiation plants has been reduced from 7.5 per cent to 2.5 per cent. Import of critical raw materials for steel industry, such as coking coal, non-coking coal and scrap are subject to zero or very low levels of custom duty.

(Source: <http://www.ibef.org/industry/steel.aspx> last visited on May 23, 2014)

Road Ahead

The future of the Indian steel industry is bright. The government plans to increase infrastructure spending from the current 5 per cent GDP to 10 per cent by 2017, and the country is committed to investing US\$ 1 trillion in infrastructure during the 12th Five-Year plan. "Taking 15 per cent as steel component in the total investment, then it can generate additional demand worth US\$ 75 billion of steel in the next few years or US\$ 15 billion worth of additional demand a year or in terms of quantity, an additional demand of 18.75 MT per annum," as per Mr C S Verma, Chairman, SAIL.

With urban population increasing globally, there is a greater need for steel to build public-transport infrastructure. Emerging economies will also continue to be a major driver of demand as these necessitate a huge amount of steel for urbanisation and industrialisation. The sector is expected to see an investment to the tune of about ₹ 2 trillion (US\$ 33.06 billion) in the coming years, as per domestic giant, Tata Steel.

(Source: <http://www.ibef.org/industry/steel.aspx> last visited on May 23, 2014)

OUR BUSINESS

We are mainly a manufacturer of roofing sheets and roofing accessories such as Colour Coated Roof Sheets, FRP Roof Sheets, Polycarbonate Sheets. We also manufacture Eco Ventilators and other miscellaneous Roofing Accessories and provide all roofing solutions our valuable customers, under one roof. We believe that we have built domain expertise in roofing solutions in a short span which has contributed in our business growth. Promoters of our Company have been associated with roofing industry since more than a decade.

Our Company was incorporated in 2008, with foraying into business of marketing of roofing sheets and started trading of the same afterwards. We have started our commercial production in the year 2012, since than our continued rapid growth is a testament to the certainty, our Customers experience every day.

Registered office of our Company is at 3/2, Labdhi Industrial Estate, Acid Mill Compound, Ranmukteshwar Road, Pratapnagar, Vadodara, 390004, Gujarat, India.

Our manufacturing facility is situated at Plot No. 06, Raj Industrial Estate, Vadadala, Near Samlatya Crossing, Vadodara, 391520, Gujarat. The products manufactured by our Company are made on automatic and semi automatic Roll forming machine, Crimping Machine, Shearing Machine and folding machine.

Our Company's Total Income and Restated Profit after Tax for the year ended March 31, 2013 was ₹ 1715.51 Lacs and ₹ 64.14 Lacs respectively. For the 9 months period ended on December 31, 2013, our Company's Total Income and Restated Profit after Tax was ₹ 1411.58 Lacs and ₹ 30.80 Lacs, respectively.

OUR MANUFACTURING FACILITY



Bansal Roofing Products Limited



List of major machinery Installed at our factory is as follows:-

Sr. No.	Description	Make	Year of Installation
	Roll Forming Machine	Chaina International Ltd. - Hongkong	2012
	Crimping Machine (Dual Crimp)	Chaina International Ltd. - Hongkong	2012
	Shearing Maching	Machine Tools Traders – Mumbai	2012
	Bending Machine	Machine Tools Traders – Mumbai	2012
	De Coiler – 5 Tonne	Bhavita Engineering - Vadodara	2012
	EOT Crane – 5 Tonne	Sahjanand Infratech – Vadodara	2012
	EOT Crane – 5 Tonne	Sahjanand Infratech – Vadodara	2013
	Uncoiler Machine & Hydra Power Pack	Hrishita Engineering – Rajkot	2013
	Hydraulic Machine & Hydraulic Showing Machine	Honour Engineering – Ulhashnagar	2013
	Gamq Slitting Machine	Nishat Engineering Works – Mumbai	2013

Details of Installed Capacity of our factory are as follows:-

Sr. No.	Description of each class of goods manufactured	Unit of Measure	Annual Capacity	Production
1.	Roll Formed Metal Product	Metric Ton	9000	
2.	FRP Products	Metric Ton	100	
3.	Ventilator	Unit	3000	

Capacity and Capacity utilization

Products	Unit	Current		Estimated		
		2012-2013	2013-2014	2014-15	2015-16	2016-17
Roll Formed Metal Product						
Capacity	Metric Ton	9000	9000	9000	15000	15000
Capacity Utilisation	Metric Ton	2776.279	2919.172	4000	9000	14000
FRP Products						
Capacity	Metric Ton	100	100	100	100	125
Capacity Utilisation	Metric Ton	7.174	35.459	40	75	100
Ventilator						
Capacity	Unit	3000	3000	3000	3000	5000
Capacity Utilisation	Unit	384	798	1000	2500	3000

OUR PRODUCTS

We are manufacturer roofing sheets and roofing accessories such as Colour Coated Roof Sheets, FRP Roof Sheets, Polycarbonate Sheets. We also manufacture Eco Ventilators and other miscellaneous Roofing Accessories. The nature of our products is durable. Our products is be used by individual consumers and industries/business for their various roofing needs. Brief summary of our products is enlisted below:

1. Roll Forming products

Roll forming products include Colour coated roof sheet which includes PPGI/PPGL/PPAL corrugated roof sheets. We supply a quality range of **Color Coated Sheets** that is manufactured using quality material. These sheets are available in the varied thickness and designs to cater client’s needs.

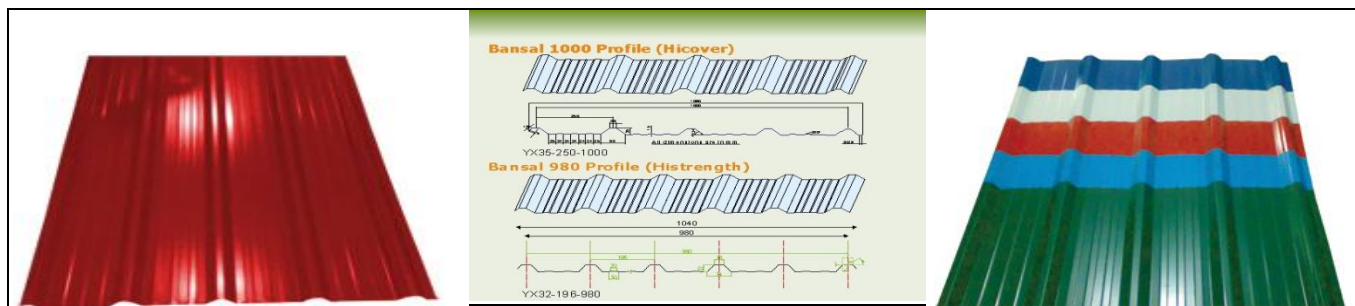

Production Process

Decoiling – place the coil in decoiler

Feeding of coil – insert plain sheet in machine

Roll forming – start the process of roll forming. Machine is having 20 line of rollers. These rollers presses the plain sheet and make it short in width and corrugations are formed

Measuring length – set commands in plc so that machine stops at set length

Plc send command to power pack which ultimately acts cutter to cut the set length.

Output products – finished product. Stack on pallet and pack it plastic and p.p. strapping

2. FRP/Polycarbonate Sheets

These are light weights, strong flat sheets in different thicknesses. Transparency is like glass. It is very strong and available from 1.5 mm. to 20 mm. thickness.



Production Process

Cutting – cut polyester film excess to size of actual sheet to be produced.

Layin of chopped mat – lay mat of required gsm on polyester film.

Moulding – wet the glass chopped mat properly (this process is known as moulding) with polyester resin. Mekp is to be added in resin for increasing gel period

Put another polyester film of same size and release air by manually pressing the whole moulded sheet.

Allow to dry and cut to size

Output products – finished product

3. Eco Ventilators

Eco Ventilator is a self driven equipment installed on industrial roofs to extract inside air. Turbo ventilators are driven by wind hence no electricity or other power sources are required. As the ventilator is rotated by wind, the stale inside air is exhausted through it natural inward flow of fresh air is boosted. It's Low cost equipment which saves energy while minimal maintenance cost and has been recommended by various energy audits.

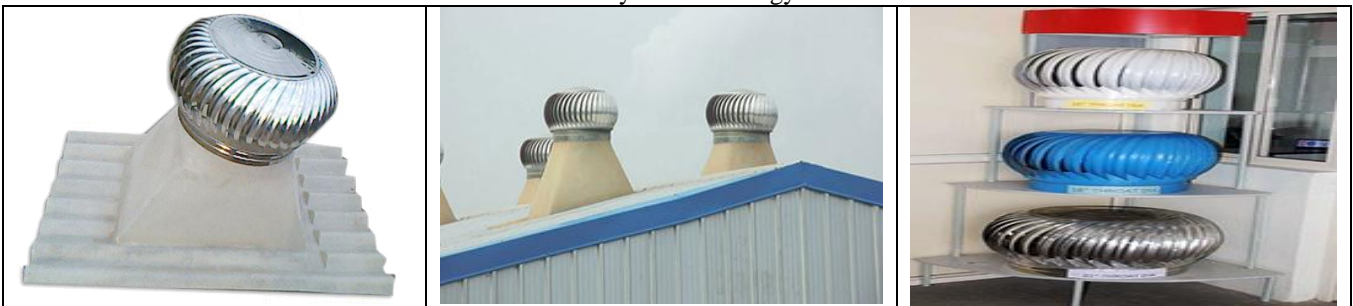

Production Process

- *Cutting of Aluminium Blade and curve it in press*
- *Making aluminium holding ring*
- *Assembly of numbers of blades with aluminium holding ring and upper aluminium V*
- *Tie aluminium ring with tie rod and holding fish*
- *Making stainless steel holding ring*
- *Fixing of shaft with stainless steel holding rings*
- *Fixing of top assembly of fins, aluminium rings, tie rod, holding fish together with sleeve and insert the same in shaft with stainless steel holding rings*
- *Fixing of Top Cover, Balancing Test & packing*

How does it works

The turbo ventilator operates by utilizing the velocity of the wind to induce air flow by centrifugal action. The centrifugal force caused by the spinning vanes creates a region of low pressure area which draws air out through the vanes. Air drawn out by the vanes is continuously replaced by fresh air from the outside. The slightest breeze will cause the turbine to spin and even after the breeze has stopped, the flywheel effect of the rotor cage will use its stored energy to continuously remove air giving rise to ventilation, suction is maintained even at low wind velocities.

Benefits

If the interior of the building gets hot and stale, there are always doors or windows that can be opened to provide for the ventilation. However, stale and hot air does not disperse by itself and opening doors or windows is simply not sufficient to provide adequate ventilation in most areas. The turbo ventilator also helps to prevent condensation by extracting moisture, condensate, and in the case of fire will extract smoke and fumes thus preventing the building from becoming smoke filled.

4. Colour Coated Roof Accessories

We offer a wide range of roofing accessories which includes Ridges, corners, capping, Gable, Gutter, Louvers, Z and C Purlins, PVC Cap For SDT Screw, foam Filler (For Ends): Silicon Sealant For Gap/Screws, Butyl Tape, Roofing Fasteners : (Self Drilling Cum Tapping Screws (SDT)), which are required in pre-engineering buildings with metal sheets.

These accessories also provide extra safety features, added designs and water sealing features.

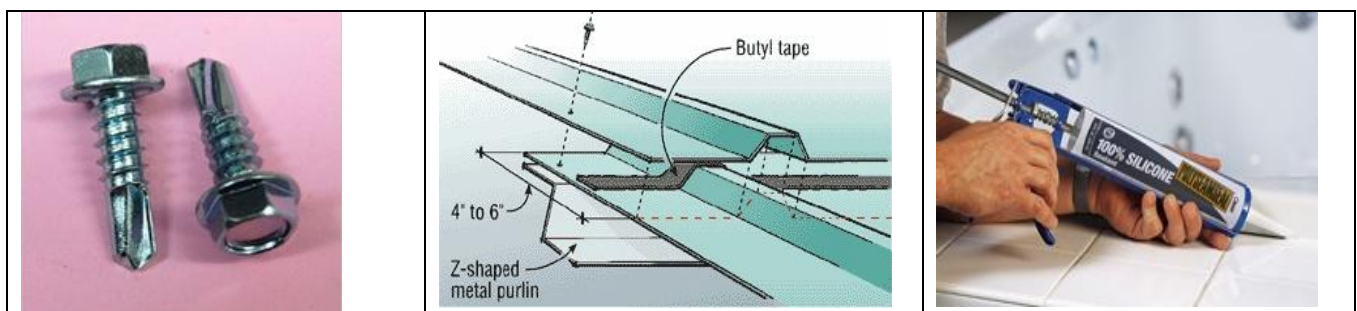

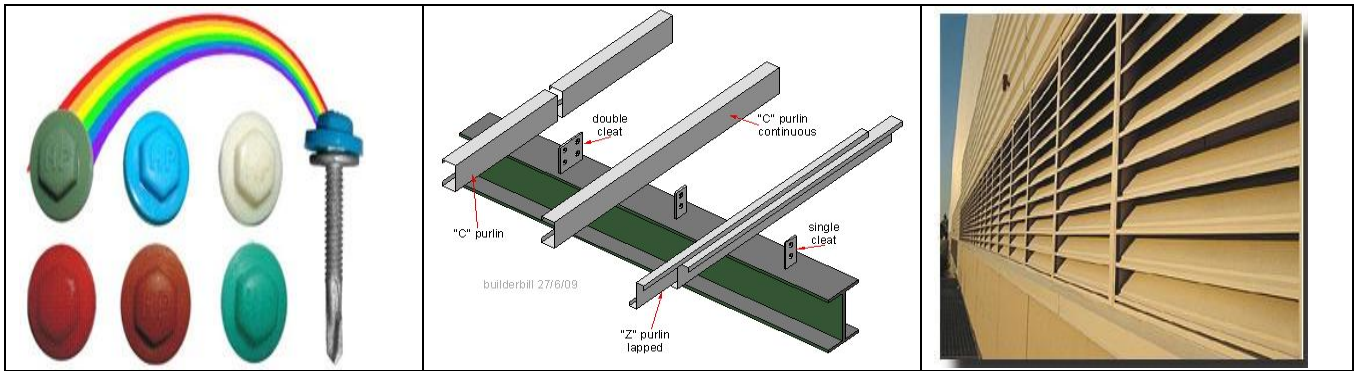

5. Other Products

- *Bunk House (Pre-Fabricated House)*
- *Security cabins*
- *PVC Curtains*

OUR COMPETITIVE STRENGTH

We believe that the following are our primary competitive strength:

1. Experienced Management Team

We benefit from the leadership of our management team, which has extensive experience in roofing industry. Our Promoters have more than adequate experience in roofing industry and we have successfully grown under their efficient leadership in the past. Our Promoters are actively involved in our operations and bring to our Company their vision and leadership which we believe has been instrumental in sustaining our business operations. Our Company feels that the strength of any successful organization lies in the experience and guidance of its team leaders and staff alike. Our key managerial personnel are largely responsible for successful execution of our growth strategy by developing new customer base and strengthening our customer relationships.

2. Strong Range of Products, Strong Brand Image

Over the years we have strengthened our products portfolio in order to address the varied and expanding requirement of our customers. Our products portfolio include Colour Coated Roof Sheets, FRP Roof Sheets, Polycarbonate Sheets, Turbo Ventilators and other miscellaneous Roofing Accessories. We believe that our product portfolio allow our customers to source all products under one roof to fulfil their roofing requirements, which helps us to expand our business from existing customers as well as address potential new customers. We believe our products portfolio provide our customers one stop solution for their roofing requirements

Over the years we have successfully developed a strong and reliable brand image for our Company, which provides us a competitive edge over other competitor.

3. Quality Assurance and Standards

We believe in providing our customers the best possible quality. All products that leave the factory premise goes through stringent quality check. Also, quality check is done at every stage of manufacturing to ensure the adherence to desired specifications. Since, our Company is dedicated towards quality of products, processes and inputs; we get repetitive orders from our buyers, as we are capable of meeting their quality standards.

4. Extensive and Cost beneficial Manufacturing Facility

Our manufacturing facility has all good facility. We believe that this enables us to control costs and increase our profit margins and gives us a competitive advantage over some of our competitors who do not have their own manufacturing facilities. We believe that our large skilled workforce with knowledge and expertise in roofing industry is a key competitive strength that has enabled us to establish and maintain our reputation and brand.

OUR BUSINESS STRATEGY

1. Increasing our geographical reach

Roofing markets have shown increased growth with many projects coming up in real estates, infrastructural developments. With thrust in the development of core infrastructure we believe there are ample opportunities available for us to cater to the ever expanding requirement. Accordingly we promote our products in India as well as in African markets through our marketing managers and executives, who help in understanding client requirements and oversee execution into desired products.

2. Focus on Cordial relations with our Suppliers, Customers and employees

We believe in developing and maintaining long term sustainable relationships with our suppliers, consumers and employees which will help us in achieving the goals set, particularly in view of entering in to new markets. We offer wide range of products at competitive prices, which will help us achieve consumer satisfaction and build long term relationships, which will translate into repeated sales.

3. To build-up a professional organization

As an organization we believe in transparency and commitment in our work among our work force and with our suppliers, customers, government authorities, banks, financial institutions etc. We have employed experienced persons for taking care of our day to day activities. We also consult with outside agencies on a case to case basis on technical and financial aspects of our business. Hence, the philosophy of professionalism is foundation stone of our business strategy and we wish to make it more sound and strong in times to come.

SWOT ANALYSIS

Strength

- ✓ Experienced, technically sound Management
- ✓ Insights of Industry
- ✓ Total solutions to customers

Weakness

- ☒ Dependency on economic growth of national economy at large
- ☒ Capital Intensive industry
- ☒ Low margin,

Opportunities

- ✓ Boon in Core Infrastructure development
- ✓ Potential to add capacity in the existing facility
- ✓ Increasing interest for metal roofing

Threat

- ☒ Volatile Raw material pricing
- ☒ Competition from cash rich companies

FUTURE PROSPECTS

Backward Integration

Currently, we purchase color coated galvanized steel rolls from our suppliers. However, in future we intend to purchase only steel rolls and to color those sheets at our end. Further we intend to move towards galvanizing steel rolls from cold rolls, converting hot rolls into cold rolls gradually, which will enable us to decrease our dependency on our raw material suppliers and taking our business to new levels.

MARKETING STRATEGY

Our Company is based in Gujarat. We use print media advertisements, pamphlets for local area distribution, Newspaper advertisements in local publications with a view to create a visibility. Further, the Company has planned a marketing strategy Audio Promotion via radio channels, Print Promotion- Newspaper Ads, Posters, Online Promotion through Internet; and Freebies like Vouchers. Our Marketing Manager and export manager has also extensively marketed our product in African country which will help us in increasing our production.

Markets

Our major share of revenue comes from local market only where we sell our products directly to our customer which has been marketed by our marketing executives. Our factory is in Vadodara in the State of Gujarat. We do not have any other branches/ factories apart from our factory at Vadodara in Gujarat.

Competition

Our Industry is diversified including both large established players and small unorganized players. We have to compete with organized as well as unorganized sector on the basis of availability of product, product quality, product range. Further, there are no entry barriers in this industry and any expansion in capacity of existing manufacturers would further intensify competition. Some of our major competitors are as follows:

- Tata BlueScope Steel Limited
- Indian Steel Corporation Limited

Collaborations/Tie Ups/ Joint Ventures

As on date of this Prospectus, we do not have any Collaboration/Tie Ups/ Joint Ventures.

Export Obligation/prospect

Our Company does not have any export obligation as on date.

Awards and Accreditations

Our Company has been awarded with “NSIC – CRISIL Rating: SE-2B (High Performance Capability and Moderate Financial Strength)” vide their report dated December 28, 2013.

UTILITIES

Raw Material

The main Raw Material for is color coated steel rolls and aluminum, which is sourced locally. The list of top ten suppliers as on December 31, 2013 is as follows:

Sr. No.	Name	Amount (₹ in Lacs)	% of Sales
1.	Manaksia Limited	829.90	64.92%
2.	Indian Steel Corporation Ltd.	263.84	20.64%
3.	Bhushan Steel Limited	77.20	6.04%
4.	Steel Smith Continental Mfg. Pvt. Ltd.	33.08	2.59%
5.	Reichhold India Pvt. Ltd.	19.25	1.51%
6.	Asarco Steel Pvt. Ltd.	8.62	0.67%
7.	Aaryan Composites	8.57	0.67%
8.	Pennar Industries Limited	7.88	0.62%
9.	JSK Industries Pvt. Ltd.	3.57	0.28%
10.	Primacy Systems Pvt. Ltd.	3.28	0.26%
Total		1255.19	98.19%

Bansal Roofing Products Limited

Power

The main utility required is Power. We have made necessary arrangements for regular uninterrupted power supply at our factory. We meet our power requirements from the connection taken from Madhya Gujarat Vij Company Limited (“MGVCL”) at our factory premises. Details of Electricity connection is as follows:-

Name of Electric Supplying Company	Total Meter in Factory	Electricity		Sanctioned Electricity Load	
		Consumer No	Meter No.	Unit of Measurement HP/Khh/Others)	Quantity
MGVCL	1	02834/02014/0	MCT/09943	HP	36.0

Water

Our operations do not envisage any major water requirements.

Manpower

Our Company is committed towards creating an organization that nurtures talent. We provide our employees an open atmosphere with a continuous learning platform that recognizes meritorious performance.

In addition to employees on our pay roll we have made an agreement with Carewell Services, Vadodara for providing labours on contractual basis at our factory premises. For the month ended on April 30, 2014 we have hired 10 labours from Carewell Services. The details of our manpower as on April 30, 2014 is as follows:-

Category	Company Pay Roll	Contract Labour	Total
Director	2	0	2
Skilled	18	0	18
Semi Skilled	4	9	13
Unskilled	3	1	4
Total	27	10	37

PROPERTY

We have our properties located at following:

Owned Properties

The following properties are owned by us:

S. No.	Buyer	Seller	Brief Particulars	Considerations & Date of Sale Deed/Agreement	Usage	Remark
1.	“Bansal Roofing Products Limited” then “Bansal Roofing Private Limited”	(1) Kalpesh Ramanlal Thakkar, Occupation: Business. Address: 1, Shivam Complex, Near, Bhddhdev Colony, Karelibaug, Vadodara (2) Ritaben Kalpesh Thakkar, Occupation: Business. Address: 1, Shivam Complex, Near, Bhddhdev Colony, Karelibaug, Vadodara (3) Naimikshaben Dineshchandra Thakkar, Occupation: Business, Address:- 19, Kirtikunj Soceity, Karelibaug, Vadodara (4) Arpita Dineshchandra Thakkar, Occupation: Business, Address:- 19, Kirtikunj Soceity, Karelibaug, Vadodara	Plot No. 6, Raj Industrial Area, Jarod - Samlay Road, Taluka, Savli admeasuring about 1755.00 Sq. Mtr. and 242.25 Sq. Mtr. area of Common land totalling to 1997.25 Sq. Mtr.	₹ 12,50,000 & August 5, 2011	Factory	The title for the property is not clear and the Company has taken appropriate steps to rectify the same.#

Bansal Roofing Products Limited



#The previous owners of the said land has certain anomalies in relation to the title. The same was not disclosed to us while purchasing the land. Subsequently the Company came to know about the same and has initiated appropriated proceedings to rectify the title of the property. Owing to the same, Company is yet to receive the property card related to the property and other related documents.

Leased Properties

S. No.	Licensor	Licensee	Address	Consideration	Usage	Details of the Lease deed
1.	Mrs. Sangeeta K. Gupta	Bansal Roofing Products Limited	3/2, Labdhi Industrial Estate, Acid Mill Compound, Ranmukteshwar Road, Pratapnagar, Vadodara - 390004, Gujarat, India	₹ 15,000 per month	Registered Office	Renewed on March 1, 2014 for 11 months

INTELLECTUAL PROPERTY

We have made application for following trademarks with the Trade Marks Registry. The details of which are as follows:

S. No.	Trademark	Class	Applicant Name	Application No. & Date	Status
1.	 (Label Mark)	19	Bansal Roofing Products Limited	2693319, March 6, 2014	Pending for Approval
2.	 (Label Mark)	6	Bansal Roofing Products Limited	2693320, March 6, 2014	Pending for Approval

Insurance Details: We have taken different insurance policies under Standard fire and special peril policy, machinery breakdown, burglary and vehicles insurance policies, brief details of which are as under:

S. No.	Policy No.	Policy Details	Insurance Details	Property Insure	Sum Insured (₹)	Date of Expiry of the Policy
1.	4010/87363 452/00/000	ICICI Lombard General Insurance Company Limited	Workman Compensation Insurance	Workman Compensation Liability	53,31,30 0.00	27/02/2 015
2.	F0134665	Future Generali India Insurance Co. Ltd.	Fire and Allied Perils , Burglary & House Breaking Insurance, Electronic Equipments, Money	Building, Stock and stock in process, Plant & Machinery, Equipments, Money in safe and Money in Transit	11,14,00, 000.00	26/05/2 015
3.	2014- C0721688- MLO	Future Generali India Insurance Co. Ltd.	Marine Cargo Open Policy-Inland	Colour Coated Roofing Sheets, Poly Carbonate, FRP, PVC, Turbo Ventilator and Similar goods	5,00,00,0 00.00	28/02/2 015
4.	1001/87524 116/00/000	ICICI Lombard General Insurance Company Limited	Standard Fire and Allied Perils Insurance	Building, Furniture, Fixtures & fitting ,Stock, Plant & Machinery, Others (Other than Stock)	25,00,00 0.00	09/02/2 015

KEY INDUSTRY REGULATIONS AND POLICIES

The business of our Company requires, at various stages, the sanction of the concerned authorities under the relevant Central, State legislation and local bye-laws. The following description is an overview of certain laws and regulations in India, which are relevant to our Company. Certain information detailed in this chapter has been obtained from publications available in the public domain. The regulations set out below are not exhaustive, and are only intended to provide general information to applicants and is neither designed nor intended to be a substitute for professional legal advice.

The statements below are based on current provisions of Indian law, and the judicial and administrative interpretations thereof, which are subject to change or modification by subsequent legislative, regulatory, administrative or judicial decisions. For details of government approvals obtained by us, see the section titled **“Government and Other Approvals”** beginning on page 157 of this Prospectus.

INDUSTRIAL LAWS

Industrial (Development and Regulation) Act, 1951

The Industrial (Development and Regulation) Act, 1951 has been Liberalized under the New Industrial Policy dated July 24, 1991, and all industrial undertakings are exempt from Licensing except for certain industries such as distillation and brewing of alcoholic drinks, cigars and cigarettes of tobacco and manufactured tobacco substitutes, all types of electronic aerospace and defence equipment, industrial explosives including detonating fuses, safety fuses, gun powder, nitrocellulose and matches and hazardous chemicals and those reserved for the small scale sector. An industrial undertaking, which is exempt from Licensing, is required to file an Industrial Entrepreneurs Memorandum ("IEM") with the Secretariat for Industrial Assistance, Department of Industrial Policy and Promotion, Ministry of Commerce and Industry, Government of India, and no further approvals are required.

Bombay Shops and Establishment Act 1948

The Bombay Shops and Establishment Act applies to shops and establishments within the State of Gujarat and lays down guidelines regulating the hours of work, payment of wages, leave holidays, terms of service, overtime and other conditions of work of persons employed in shops, commercial establishments. It also discourages employers from engaging in any kind of malpractices towards their employees. This legislation governs our Company as the Company has its registered office in the city of Vadodara

Approvals from Local Authorities

Setting up of a Factory or Manufacturing/Housing unit entails the requisite Planning approvals to be obtained from the relevant Municipal and Local Panchayat(s) within the city limits and outside the city limits. Consents from the state Pollution Control Board(s), the relevant state Electricity Board(s), the State Excise Authorities, Sales Tax, are required to be obtained before commencing the building of a factory or the start of manufacturing operations.

LAWS REGULATING FOREIGN TRADE AND INVESTMENT

FEMA Regulations

As laid down by the FEMA Regulations, no prior consents and approvals are required from the Reserve Bank of India, for Foreign Direct Investment under the ‘automatic route’ within the specified sectoral caps. In respect of all industries not specified as FDI under the automatic route, and in respect of investment in excess of the specified sectoral limits under the automatic route, approval may be required from the FIPB and/or the RBI. The RBI, in exercise of its power under the FEMA, has notified the Foreign Exchange Management (Transfer or Issue of Security by a Person Resident Outside India) Regulations, 2000 ("FEMA Regulations") to prohibit, restrict or regulate, transfer by or issue of security to a person resident outside India. Foreign investment in India is governed primarily by the provisions of the FEMA which relates to regulation primarily by the RBI and the rules, regulations and notifications there under, and the policy prescribed by the Department of Industrial Policy and Promotion, Ministry of Commerce & Industry, Government of India.

Foreign Trade (Development and Regulation) Act, 1992

This statute seeks to increase foreign trade by regulating the imports and exports to and from India. This Legislation read with the Indian Foreign Trade Policy provides that no export or import can be made by a person or company without an

Bansal Roofing Products Limited

importer exporter code number unless such person or company is specifically exempt. An application for an importer exporter code number has to be made to the office of the Joint Director General of Foreign Trade, Ministry of Commerce. An importer-exporter code number allotted to an applicant is valid for all its branches, divisions, units and factories.

WORKS AND LABOUR LAWS

Factories Act, 1948

Factories Act, 1948 is a social Legislation which has been enacted to regulate the occupational safety, health and welfare of workers at work places. This Legislation is being enforced by the Government through officers appointed under the Act i.e. Inspectors of Factories, Deputy Chief Inspectors of Factories who work under the control of the Chief Inspector of Factories and overall control of the Labour Commissioner.

Payment of Wages Act, 1936 (“Wages Act”)

The payment of Wages Act, 1936 is a central legislation which applies to the persons employed in the factories and to persons employed in industrial or other establishments where the monthly wages payable to such persons is less than ₹ 18,000/-. The Act confers on the person(s) responsible for payment of wages certain obligations with respect to the maintenance of registers and the display in such factory/establishment, of the abstracts of this Act and Rules made there under.

Minimum Wages Act, 1948 (“Minimum Wages Act”)

The Minimum Wages Act, 1948 was enacted to provide for minimum wages in certain employments. Under this Act, the Central and the State Governments are the authorities to stipulate the scheduled employment and to fix minimum wages. The Act contains list of Agricultural and Non Agricultural employment where the prescribed minimum rate of wages is to be paid to the workers. The minimum wages are calculated and fixed based on the basic requirement of food, clothing, housing required by an average Indian adult.

Employees (Provident Fund and Miscellaneous Provisions) Act, 1952

The Act is applicable to factories employing more than 20 employees and may also apply to such establishments and industrial undertakings as notified by the Government from time to time. All the establishments under the Act are required to be registered with the Provident Fund Commissioners of the State. Also, in accordance with the provisions of the Act, the employers are required to contribute to the Employees' Provident Fund, the prescribed percentage of the basic wages, dearness allowances and remaining allowance (if any) payable to the employees. The employee shall also be required to make the equal contribution to the fund. A monthly return is required to be submitted to the commissioner in addition to the maintenance of registers by the employers.

Employees State Insurance Act, 1948, as amended (the “ESIC Act”)

The ESI Act, provides for certain benefits to employees in case of sickness, maternity and employment injury. All employees in establishments covered by the ESI Act are required to be insured, with an obligation imposed on the employer to make certain contributions in relation thereto. In addition, the employer is also required to register itself under the ESI Act and maintain prescribed records and registers.

Payment of Gratuity Act, 1972

A terminal Lump sum benefit paid to a worker when he or she Leaves employment after having worked for the employer for a prescribed minimum number of years is referred to as "gratuity." The Payment of Gratuity Act extends to the whole of India and is applicable to all factories, mines, oilfields, plantations, ports, railway companies and any establishments where 10 or more persons were employed on any day of the preceding 12 months and every Shop and Establishment of that State, in which 10 or more persons are employed, or were employed on any day in the preceding 12 months. The Act provides that within 30 days of opening of the establishment, it has to notify the controlling authority in Form A and thereafter whenever there is any change in the name, address or change in the nature of the business of the establishment a notice in Form B has to be filed with the authority. The Employer is also required to display an abstract of the Act and the rules made there under in Form U to be affixed at the or near the main entrance. Further, every employer has to obtain insurance for his Liability towards gratuity -payment to be made under Payment of Gratuity Act 1972, with Life Insurance Corporation or any other approved insurance fund.

Bansal Roofing Products Limited

Payment of Bonus Act, 1965

The Payment of Bonus Act, 1965 is applicable to every establishment employing 20 or more employees. The said Act provides for payment of the minimum bonus to the employees specified under the Act. It further requires the maintenance of certain books and registers such as the register showing computation of the allocable surplus; the register showing the set on & set off of the allocable surplus and register showing the details of the amount of Bonus due to the employees. Further it also requires for the submission of Annual Return in the prescribed form to be submitted by the employer within 30 days of payment of the bonus, to the Inspector appointed under the Act.

Industrial Disputes Act, 1947 and Industrial Dispute (Central) Rules, 1957

The Industrial Disputes Act extends to whole of India and applies to every industrial establishment carrying on any business, trade, manufacture or distribution of goods and services irrespective of the number of workmen employed therein. Industrial Dispute Act, 1947 provides for the investigation and settlement of industrial disputes. It also contains various provisions to prohibit strikes and lock-outs, declaration of strikes and lockouts as illegal and provisions relating to layoff and retrenchment and closure, Conciliation and adjudication of industrial disputes by; Conciliation Officers, a Board of Conciliation, Courts of Inquiry, Labour Courts, Industrial Tribunals and a National Industrial Tribunal.

Trade Union Act, 1926

Provisions of the Trade Union Act, 1926 provides that any dispute between employers and workmen or between workmen and workmen, or between employers and employers which is connected with the employment, or non employment, or the terms of employment or the conditions of labour, of any person shall be treated as trade dispute. For every trade dispute a trade union has to be formed. For the purpose of Trade Union Act, 1926, Trade Union means combination, whether temporary or permanent, formed primarily for the purpose of regulating the relations between workmen and employers or between workmen and workmen, or between employers and employers, or for imposing restrictive condition on the conduct of any trade or business etc.

The Workmen Compensation Act, 1923

The Workmen Compensation Act, 1923 ("WCA") has been enacted with the objective to provide for the payment of compensation to workmen by employers for injuries caused due to accidents arising out of and in the course of employment, and for occupational diseases resulting in death or disablement. The WCA makes every employer liable to pay compensation if personal injury, disablement either partial or total or loss of life is caused to a workman (including those employed through a contractor) by accident arising out of and in the course of his employment. In case the employer fails to pay compensation in accordance with the provisions of WCA within one month from the date it falls due, the commissioner appointed under the WCA may direct the employer to pay the compensation amount along with interest and may also impose a penalty.

Contract Labour (Regulation and Abolition) Act, 1970, as amended (the "CLRA Act")

In respect of each of its facilities, the Company uses the services of certain licensed contractors who in turn employ contract labour whose number exceeds 20 in respect of each facility. Accordingly, the Company is regulated by the provisions of the CLRA Act which requires the Company to be registered as a principal employer and prescribes certain obligations with respect to welfare and health of contract labour. The CLRA Act requires the principal employer of an establishment to which the CLRA Act applies to make an application to the concerned officer for registration of the establishment. In the absence of registration, contract labour cannot be employed in the establishment. Likewise, every contractor to whom the CLRA Act applies is required to obtain a license and not to undertake or execute any work through contract labour except under and in accordance with the license issued. The CLRA Act imposes certain obligations on the contractor in relation to establishment of canteens, rest rooms, drinking water, washing facilities, first aid, other facilities and payment of wages. However, in the event the contractor fails to provide these amenities, the principal employer is under an obligation to provide these facilities within a prescribed time period. Penalties, including both fines and imprisonment, may be levied for contravention of the provisions of the CLRA Act.

The Industrial Employment (Standing Order) Act, 1946

Under the Industrial Employment Standing Orders Act, 1946 every establishment employing more than 50 employees is required to formulate rules and regulations for its employees and the same should be submitted for approval to the Deputy Labour Commissioner

Bansal Roofing Products Limited

The Equal Remuneration Act, 1976 ("Equal Remuneration Act") and Equal Remuneration Rules, 1976

The Equal Remuneration Act provides for payment of equal remuneration to men and women workers, for the same work and prevents discrimination on the grounds of sex against women in the matter of employment, recruitment and for matters connected therewith or incidental thereto.

The Maternity Benefit Act, 1961 ("Maternity Act")

The purpose of Maternity Act 1961 is to regulate the employment of pregnant women and to ensure that they get paid leave for a specified period during and after their pregnancy. It provides inter-alia for payment of maternity benefits, medical bonus and enacts prohibition on dismissal, reduction of wages paid to pregnant women etc.

Child Labour (Prohibition and Regulation) Act, 1986

This statute prohibits employment of children below 14 years of age in certain occupations and processes and provides for regulation of employment of children in all other occupations and processes. The Act applies to all establishments and workshops wherein any industrial process is carried on, but does not apply to any factory to which Section 67 (Employment of Child Labour) of the Factories Act, 1948 applies.

Apprentices Act, 1961, as amended (the "Apprentices Act")

The Apprentices Act was enacted in 1961 for imparting training to apprentices i.e. a person who is undergoing apprenticeship training in pursuance of a contract of apprenticeship. Every employer shall make suitable arrangements in his workshop for imparting a course of practical training to every apprentice engaged by him in accordance with the programme approved by the apprenticeship adviser. The central apprenticeship adviser or any other person not below the rank of an assistant apprenticeship adviser shall be given all reasonable facilities for access to each apprentice with a view to test his work and to ensure that the practical training is being imparted in accordance with the approved programme.

ENVIRONMENTAL LAWS

Environment (Protection) Act, 1986

The Environment (Protection) Act, 1986 was enacted as a general legislation to safeguard the environment from all sources of pollution by enabling coordination of the activities of the various regulatory agencies concerned, to enable creation of an authority with powers for environmental protection, regulation of discharge of environmental pollutants etc. The purpose of the Act is to act as an "umbrella" legislation designed to provide a framework for co-ordination of the activities of various central and state authorities established under previous laws, such as Water Act & Air Act. It includes water, air and land and the interrelationships which exist among water, air and land, and human beings and other living creatures, plants, microorganisms and property.

Air (Prevention and Control of Pollution) Act 1981 ("Air Act")

The Air (Prevention and Control of Pollution) Act, 1981 has been enacted to provide for the prevention, control and abatement of air pollution. The statute was enacted with a view to protect the environment and surroundings from any adverse effects of the pollutants that may emanate from any factory or manufacturing operation or activity. It lays down the Limits with regard to emissions and pollutants that are a direct result of any operation or activity. Periodic checks on the factories are mandated in the form of yearly approvals and consents from the corresponding Pollution Control Boards in the state.

Water (Prevention and Control of Pollution) Act, 1974 ("Water Act")

The Water Act was enacted in 1974 in order to provide for the prevention and control of water pollution by factories and manufacturing industries and for maintaining or restoring the wholesomeness of water. In respect to an Industrial Undertaking it applies to the (i) Occupier (the owner and management of the undertaking) (ii) outlet (iii) Pollution and (iv) Trade effluents. The Act requires that approvals be obtained from the corresponding pollution control Boards in the state.

Water (Prevention and Control of Pollution) Cess Act, 1977

The Water Cess Act is a Legislation which provides for the Levy and collection of a Cess on Local authorities and industries based on the consumption of water by such Local authorities and industries so as to enable implementation of the Water Act by the regulatory agencies concerned.

Public Liability Insurance Act, 1991

The Public Liability Insurance Act, 1991, imposes liability on the owner or controller of hazardous substances for any damage arising out of an accident involving such hazardous substances. A list of “hazardous substances” covered by the legislation has been enumerated by the Government by way of a notification. The owner or handler is also required to take out an insurance policy insuring against liability under the legislation.

The Noise Pollution (Regulation & Control) Rules 2000 (“Noise Regulation Rules”)

The Noise Regulation Rules regulate noise levels in industrial (75 decibels), commercial (65 decibels) and residential zones (55 decibels). The Noise Regulation Rules also establish zones of silence of not less than 100 meters near schools, courts, hospitals, etc. The rules also assign regulatory authority for these standards to the local district courts. Penalty for non-compliance with the Noise Regulation Rules shall be under the provisions of the Environment (Protection) Act, 1986.

CORPORATE LAWS

The Companies Act, 2013 and applicable provisions of Companies Act, 1956

The Act deals with laws relating to companies and certain other associations. It was enacted by the parliament in the year 2013. The Companies Act primarily regulates the formation, financing, functioning and winding up of companies. The Act prescribes regulatory mechanism regarding all relevant aspects including organizational, financial and managerial aspects of companies. Regulation of the financial and management aspects constitutes the main focus of the Act. In the functioning of the corporate sector, although freedom of companies is important, protection of the investors and shareholders, on whose funds they flourish, is equally important. The Companies Act plays the balancing role between these two competing factors, namely, management autonomy and investor protection.

Several provisions of the Companies Act, 2013 viz, compromise, arrangements and amalgamations, prevention of oppression and mismanagement, revival and re-habilitation of Sick Companies, winding-up, functioning of NCLT and others are yet to be notified. Accordingly, the provisions of Companies Act, 1956 for matters falling under un-notified sections of Companies Act, 2013, shall be governed by the existing provisions of Companies Act, 1956, until repealed as a result of notification of corresponding provisions of Companies Act, 2013.

INTELLECTUAL PROPERTY LAWS

Trade Marks Act, 1999

The Indian Law on trademarks is enshrined in the Trade Marks Act, 1999. Under the existing Legislation, a trademark is a mark used in relation to goods so as to indicate a connection in the course of trade between the goods and some person having the right as proprietor to use the mark. A mark may consist of a word or invented word, signature, device, Letter, numeral, brand, heading, Label, name written in a particular style and so forth. The trademark once applied for, is advertised in the trademarks journal, oppositions, if any are invited and after satisfactory adjudications of the same, a certificate of registration is issued. The right to use the mark can be exercised either by the registered proprietor or a registered user. The present term of registration of a trademark is ten years, which may be renewed for similar periods on payment of prescribed renewal fee.

PROPERTY RELATED LAWS

The Transfer of Property Act, 1882 (the “TP Act”)

The TP Act, 1882 establishes the general principles relating to the transfer of property in India. It forms a basis for identifying the categories of property that are capable of being transferred, the persons competent to transfer property, the validity of restrictions and conditions imposed on the transfer and the creation of contingent and vested interest in the property. It also provides for the rights and liabilities of the vendor and purchaser in a transaction for the sale of land.

Registration Act, 1908 (the “Registration Act”)

The Registration Act, details the formalities for registering an instrument. Section 17 of the Registration Act identifies documents for which registration is compulsory and includes, *inter alia*, any non-testamentary instrument which purports to create, declare, assign, limit or extinguish, whether in the present or in future, any right, title or interest, whether vested or contingent, in immovable property of the value of ₹ 100 or more, and a lease of immovable property for any term exceeding one year or reserving a yearly rent.

The Registration Act also stipulates the time for registration, the place for registration and the persons who may present documents for registration. Any document which is required to be compulsorily registered but is not registered will not affect the subject property, nor be received as evidence of any transaction affecting such property (except as evidence of a contract in a suit for specific performance or as evidence of part performance of a contract under the TP Act or as evidence of any collateral transaction not required to be effected by registered instrument), unless it has been registered.

The Specific Relief Act, 1963

The Specific Relief Act is complimentary to the provisions of the Contract Act and the Transfer of Property Act, as the Act applies both to movable property and immovable property. The Act applies in cases where the Court can order specific performance of a contract. Specific relief can be granted only for purpose of enforcing individual civil rights and not for the mere purpose of enforcing a civil law. ‘Specific performance’ means Court will order the party to perform his part of agreement, instead of imposing on him any monetary liability to pay damages to other party.

Indian Stamp Act, 1899 (the “Stamp Act”)

Stamp duty is payable on all instruments/ documents evidencing a transfer or creation or extinguishment of any right, title or interest in immovable property. The Stamp Act provides for the imposition of stamp duty at the specified rates on instruments listed in Schedule I of the Stamp Act. Under the Constitution of India, the states are also empowered to prescribe or alter the stamp duty payable on such documents executed within the state. Instruments chargeable to duty under the Stamp Act but which have not been duly stamped, are incapable of being admitted in court as evidence of the transaction contained therein. The Stamp Act also provides for impounding of instruments by certain specified authorities and bodies and imposition of penalties, for instruments which are not sufficiently stamped or not stamped at all.

Indian Easements Act, 1882

The law relating to easements and licenses in property is governed by the Easements Act, 1882 (the “Easements Act”). The right of easement has been defined under the Easements Act to mean a right which the owner or occupier of any land possesses over the land of another for beneficial enjoyment of his land. Such right may allow the owner of the land to do and continue to do something or to prevent and continue to prevent something being done, in or upon any parcel of land which is not his own. Easementary rights may be acquired or created by (a) an express grant; or (b) a grant or reservation implied from a certain transfer of property; or (c) by prescription, on account of long use, for a period of twenty years without interruption; or (d) local custom.

TAXATION LAWS

Income-tax Act, 1961

The Income Tax Act, 1961 deals with the taxation of individuals, corporates, partnership firms and others. As per the provisions of this Act the rates at which they are required to pay tax is calculated on the income declared by them or assessed by the authorities, after availing the deductions and concessions accorded under the Act. The maintenance of Books of Accounts and relevant supporting documents and registers are mandatory under the Act.

Central Excise Act, 1944

Excise duty is levied on production of goods but the Liability of excise duty arises only on removal of goods from the place of storage, i.e., factory or warehouse. Unless specifically exempted, excise duty is levied even if the duty was paid on the raw material used in production.

Bansal Roofing Products Limited

Custom Act, 1962

The provisions of the Customs Act, 1962 and Rules made there under are applicable at the time of import of goods into India from a place outside India or at the time of export of goods out of India to a place outside India. Any Company requiring to import or export any goods is required to get registered and obtain an Importer Exporter Code (IEC) number.

Service Tax

Service tax is charged on taxable services as defined in Chapter V of Finance Act, 1994, which requires a service provider of taxable services to collect service tax from a service recipient and pay such tax to the Government. In accordance with Rule 6 of Service tax Rules, every assessee is required to pay Service tax by 5th of the month immediately following the month to which it relates. Further under Rule 7 (1) of Service Tax Rules, the company is required to file a half yearly return by 25th of the month immediately following the half year to which the return relates.

Central Sales Tax Act (CST)

The main object of this act is to formulate principles for determining (a) when a sale or purchase takes place in the course of trade or commerce (b) When a sale or purchase takes place outside a State (c) When a sale or purchase takes place in the course of imports into or export from India, to provide for Levy, collected on and distribution of taxes on sales of goods in the course of trade or commerce, to declare certain goods to be of special importance trade or commerce and specify the restrictions and conditions to which State Laws imposing taxes on sale or purchase of such goods of special importance (called as declared goods) shall be subject. CST Act imposes the tax on interstate sales and states the principles and restrictions as per the powers conferred by Constitution.

Value Added Tax ("VAT")

VAT is a system of multi-point Levy on each of the purchases in the supply chain with the facility of set-off input tax on sales whereby tax is paid at the stage of purchase of goods by a trader and on purchase of raw materials by a manufacturer. VAT is based on the value addition of goods, and the related VAT Liability of the dealer is calculated by deducting input tax credit for tax collected on the sales during a particular period. VAT is a consumption tax applicable to all commercial activities involving the production and distribution of goods and the provisions of services, and each state that has introduced VAT has its own VAT Act, under which, persons Liable to pay VAT must register and obtain a registration number from Sales Tax Officer of the respective State.

BUSINESS LAWS

Indian Contract Act 1872

Indian Contract Act 1872 is the main source of law regulating contracts in Indian law, as subsequently amended. It is not a complete and exhaustive law on all types of contracts. It determines the circumstances in which promise made by the parties to a contract shall be legally binding on them. Each contract creates some right and duties upon the contracting parties. Indian contract deals with the enforcement of these rights and duties upon the parties. As per the provisions of the Indian Contract Act all agreements are contracts if they are made by the free consent of the parties competent to contract, for a lawful consideration and with a lawful object and are not expressly declared to be void. The parties to a contract must either perform or offer to perform their respective promises unless such performance is dispensed with or excused under the provisions of the Act or of any other law. When a contract has been broken the party who suffers by such breach is entitled to receive from the party who has broken the contract, compensation for any loss or damage caused to him thereby, which naturally arose in the usual course of things from such breach or which the parties knew, when they made the contract, to be likely to result from the breach of it. The Indian Contract Act also lays down provisions of indemnity, guarantee, bailment and agency. Provisions relating to sale of goods and partnership which were originally in the act are now subject matter of separate enactments viz., the Sale of Goods Act and the Indian Partnership Act.

Sale of Goods Act, 1930

The law relating to the sale of goods is codified in the Sale of Goods Act, 1930. It defines sale and agreement to sell as a contract whereby the seller transfers or agrees to transfer the property in goods to the buyer for a price and provides that there may be a contract of sale between part owner and another and that the contract of sale may be absolute or conditional. Provisions are made in this Act for existing or future goods, perishable goods, ascertainment of price, conditions and warranties, effects of the contract, delivery to carrier, duties of seller and buyer, buyers' right of examining the goods, liability of buyer for neglecting or refusing the delivery of goods, rights of unpaid seller, suits for breach of the contract, sale, etc

HISTORY AND CERTAIN CORPORATE MATTERS

Our History and Background

Our Company was originally incorporated on May 01, 2008, as “Bansal Roofing Private Limited” under the provisions of the Companies Act, 1956 with the Registrar of Companies, Gujarat, Dadra & Nagar Havelli. Pursuant to Shareholders Resolution passed at the Extra Ordinary General Meeting of the Company held on August 24, 2013, name of our Company was changed to “Bansal Roofing Products Private Limited” from “Bansal Roofing Private Limited” and a fresh Certificate of Incorporation dated August 29, 2013 was issued by the Registrar of Companies, Gujarat, Dadra & Nagar Havelli. Subsequently, our Company was converted into a public limited company pursuant to Shareholders Resolution passed at the Extra Ordinary General Meeting of the Company held on November 1, 2013 and the name of our Company was changed to “Bansal Roofing Products Limited” vide a fresh Certificate of Incorporation dated November 19, 2013 issued by the Registrar of Companies, Gujarat, Dadra & Nagar Havelli. The Corporate Identity Number of our Company is U25206GJ2008PLC053761.

Our Company was originally promoted by Mr. Kaushalkumar S Gupta, Mr Satishkumar S Gupta and Mrs. Sangeeta K Gupta who were the original subscribers to the Company’s Memorandum and Articles of Association in the year 2008.

Changes in Registered Office of the Company since incorporation

The Registered Office of the Company is situated at 3/2, Labdhi Industrial Estate, Acid Mill Compound, Ranmukteshwar Road, Pratapnagar, Vadodara – 390004, Gujarat, India.

Following change has been made in our registered office since incorporation till date of this Prospectus:

From	To	Date of Change	Reason for Change
3/2, Lubdhi Industrial Estate, Acid Mill Compound, Ranmukteshwar Road, Pratapnagar, Vadodara – 390004, Gujarat, India	3/2, Labdhi Industrial Estate, Acid Mill Compound, Ranmukteshwar Road, Pratapnagar, Vadodara – 390004, Gujarat, India	January 23, 2014	Correction in address.

Main Object of our Company

The main object of our Company as set forth in the Memorandum of Association of our Company are as follows:

- “To carry on the business of manufacturing, assembly, supply and trading of colour coated, galvanised, metal, aluminum, alloy & other sheets and accessories like ridge, corner, gutter etc., FRP sheets and allied products of similar material, polycarbonate sheet and similar products, self driven roof ventilator and similar other products, PUF insulated sheets and similar other products, polypropylene, PVC & other plastic sheets and similar products, thermal insulation products, pre-engineering buildings, prefabricated cabins, houses, “Z” and “C” purlins and other roll formed products, fabrication at site, installation and all other products and services for industrial sheds and buildings, houses, infrastructure projects.”

Changes in Memorandum of Association

Except as stated below there has been no change in the Memorandum of Association of our Company since its Incorporation:

Sr. No.	Particulars	Date of Meeting	Type of Meeting
1.	<u>Change in Clause V (Capital Clause) of the Memorandum of Association</u> Increase in the authorized share capital of the Company from ₹ 1.00 Lakh divided into 10,000 Equity Shares of ₹10.00 each to ₹ 10.00 Lakhs divided into 1,00,000 Equity Shares of ₹ 10.00 each.	05.09.2011	Extra-Ordinary General Meeting
2.	<u>Change in Clause V (Capital Clause) of the Memorandum of Association</u> Increase in the authorized share capital of the Company from ₹ 10.00 Lakhs divided into 1,00,000 Equity Shares of ₹10.00 each to ₹ 100.00 Lakhs divided into 10,00,000 Equity Shares of ₹ 10.00 each.	08.02.2013	Extra-Ordinary General Meeting
3.	<u>Change in Clause V (Capital Clause) of the Memorandum of Association</u>	24.08.2013	Extra-Ordinary

Bansal Roofing Products Limited

	Increase in the authorized share capital of the Company from ₹ 100.00 Lakhs divided into 10,00,000 Equity Shares of ₹10.00 each to ₹ 1000.00 Lakhs divided into 1,00,00,000 Equity Shares of ₹ 10.00 each.		General Meeting
4.	<u>Change in Clause I (Name Clause) of the Memorandum of Association</u> Change of name of the Company to “Bansal Roofing Products Private Limited” from “Bansal Roofing Private Limited.” Since the existing name did not represent the business of the Company properly, the name was altered to above effect.	24.08.2013	Extra-Ordinary General Meeting
5.	<u>Change in Clause III (Object Clause) of the Memorandum of Association</u> Main object of the Company was replaced by the following clause: “To carry on the business of manufacturing, assembly, supply and trading of colour coated, galvanised, metal, aluminum, alloy & other sheets and accessories like ridge, corner, gutter etc., FRP sheets and allied products of similar material, polycarbonate sheet and similar products, self driven roof ventilator and similar other products, PUF insulated sheets and similar other products, polypropylene, PVC & other plastic sheets and similar products, thermal insulation products, pre-engineering buildings, prefabricated cabins, houses, “Z” and “C” purlins and other roll formed products, fabrication at site, installation and all other products and services for industrial sheds and buildings, houses, infrastructure projects.”	10.09.2013	Extra-Ordinary General Meeting
6.	Conversion of our Company from “Private Limited” to “Limited” resulting into change of name from “Bansal Roofing Products Private Limited” to “Bansal Roofing Products Limited”. The Company proposed to increase its capital base by way of issue of shares to public and accordingly, the same was converted to “Public Limited” company resulting into change of name as detailed above.	01.11.2013	Extra-Ordinary General Meeting

Capital raising (Debt / Equity)

For details of the equity capital raising of our Company, please refer to the chapter titled "*Capital Structure*" on page 39 of this Prospectus.

We have not done any debt issuances or raised any long term debt since incorporation till date.

Key Events and Mile Stones

Year	Key Events / Milestone / Achievements
2008	Incorporation of the Company in the name and style of “Bansal Roofing Private Limited”
2012	Commencement of Operations at Company’s Manufacturing facility situated at Plot No. 06. Raj Industrial Estate, Vadadala, Near Samlatya Crossing, Vadodara, 391520, Gujarat Accredited with ISO 9001 : 2008
2013	Total Turnover of the Company crosses ₹ 1000 Lacs Change of name of the Company to Bansal Roofing Products Private Limited Conversion of our Company from Private Limited Company to Public Limited Company
2014	Awarded with “NSIC – CRISIL Rating: SE-2B (High Performance Capability and Moderate Financial Strength)”

Awards and Accreditations

Our Company has been awarded with “NSIC – CRISIL Rating: SE-2B (High Performance Capability and Moderate Financial Strength)” vide their report dated December 28, 2013.

Memberships

Our Company has been honoured with memberships of following organisations:

Name of Organisation	Type of Membership
Vadodara Chamber of Commerce and Industry	Lifetime
The Bombay Iron Merchant’s Association	Lifetime

Bansal Roofing Products Limited

Mergers/amalgamation and acquisition of business/undertakings

There has been no merger/amalgamation in the history of our Company and we have not acquired any business/undertakings since incorporation.

Defaults or rescheduling of borrowing

The Company has not defaulted or rescheduled its borrowing. Furthermore, none of the Company's loans has been converted into equity in the past.

Changes in activities of our Company during the last five (5) years

Our Company has not changed its line of activities in the last five (5) years except for expansion of range of products and commencement of our manufacturing unit during financial year 2012-2013.

Subsidiary of our Company

Our Company does not have any Subsidiary within the meaning of Section 2 (87) of the Companies Act, 2013 as on the date of this Prospectus.

Shareholders of our Company

Our Company has Seven (7) shareholders as on the date of this Prospectus. For further details on the shareholding pattern of our Company, please refer to the chapter titled “*Capital Structure*” beginning on page 39 of the Prospectus.

Shareholders Agreements

Our Company has not entered into any Shareholder's Agreement as on the date of this Prospectus.

Other Agreements

Our Company has not entered into any other material agreements, other than disclosed in this Prospectus. For further details please refer to the chapter titled “*Outstanding Litigation and Material Developments*” beginning on page 151 of the Prospectus.

Strategic Partners

Our Company does not have any strategic partners as on the date of this Prospectus.

Financial Partners

Our Company does not have any financial partners as on the date of this Prospectus.

Revaluation of Assets

Our Company has not revalued its assets since incorporation.

Injunction or restraining order

Our Company is not operating under any injunction or restraining order.

Lock-out or strikes

There have been no lock-outs or strikes in our Company since inception.

Corporate Profile of our Company

For details on the description of our Company's activities, the growth of our Company, please see “*Our Business*”, “*Management's Discussion and Analysis of Financial Conditions and Results of Operations*” and “*Basis of Issue Price*” on pages 72, 142 and 55 of this Prospectus.

OUR MANAGEMENT

Board of Directors

As per our Articles of Association our Company shall not have less than 3 (Three) and more than 12 (Twelve) Directors. Currently, our Company has 6 (Six) Directors out of which 3 (Three) are Independent Directors. We confirm that the composition of our Board of Directors complies with Clause 52 of the SME Listing Agreement of BSE.

Mr. Kaushalkumar S. Gupta, Chairman & Managing Director of our Company, Mr. Satishkumar S. Gupta, Whole-time Director, and Mrs. Sangeeta K. Gupta, Whole-time Director are suitably supported by team of experienced and qualified executives who carry out the day to day affairs of the business of our Company. All Executive Directors of our Company are under the direct control & superintendence of the Board of Directors.

The following table sets forth the details regarding the Board of Directors as on the date of filing of this Prospectus:

Sr. No.	Name, Father's Name, Age, Designation, Address, Experience, Occupation, Qualification & DIN	Date of Appointment	No. of Equity Shares held in BRPL & [% of Shareholding (Pre Issue)]	Other Director -ships
1.	Mr. Kaushalkumar S. Gupta S/o Mr. Satyanarayan R. Gupta Age: 43 Years Designation: Chairman & Managing Director Address: C- 45, Shreedharpark Society, Opposite Novino Batteries, Makarpura Road, Vadodara, 390010, Gujarat, India Experience: 22 Years Occupation: Business Qualification: Bachelor of Engineering (Industrial) DIN: 02140767	Appointed since Incorporation Designated as Managing Director since July 29, 2013 for 3(three) years.	9,56,900 Equity Shares [63.07 %]	Nil
2.	Mr. Satishkumar S. Gupta S/o Mr. Satyanarayan R. Gupta Age: 52 Years Designation: Whole-time Director Address: B-46, Girdharpark, Makarpura, Vadodara, 390010, Gujarat, India Experience: 33 Years Occupation: Business Qualification: Diploma in Mechanical Engineering & Certificate Course in Materials Management DIN: 02140734	Appointed since Incorporation Designated as Whole-time Director since July 29, 2013 for a period of 3 years subject to his liability to retire by rotation w.e.f. 14.05.2014	1,56,000 Equity Shares [10.28 %]	Nil
3.	Mrs. Sangeeta K. Gupta W/o Mr. Kaushalkumar S. Gupta Age: 41 Years Designation: Whole-time Director Address: C- 45, Shreedharpark Society, Opposite Novino Batteries, Makarpura Road, Vadodara, 390010, Gujarat, India Experience: 5 Years Occupation: Business Qualification: Master of Arts (English Entire) DIN: 02140757	Originally Appointed on Incorporation* Appointed as Whole-time Director since January 09, 2014 for a period of 3 years subject to her liability to retire by rotation.	3,64,000 Equity Shares [23.99 %]	Nil
4.	Ms. Bhavitaben D. Gurjar D/o Mr. Dilipkumar Gurjar Age: 29 Years Designation: Non-Executive Independent Director Address: C- 43, Shreedhar Park., Behind Makarpura	January 20, 2014#	Nil	Nil

Bansal Roofing Products Limited

Sr. No.	Name, Father's Name, Age, Designation, Address, Experience, Occupation, Qualification & DIN	Date of Appointment	No. of Equity Shares held in BRPL & [% of Shareholding (Pre Issue)]	Other Director-ships
	Depo., Vadodara, 390010, Gujarat, India Experience: 8 Years Occupation: Consultancy Professional Qualification: Bachelor of Commerce DIN: 06720448			
5.	Mrs. Beena P. Bisht W/o Mr. Puransingh P. Bisht Age: 38 Years Designation: Non-Executive Independent Director Address: A/8, Purusarth Bunglows, Off. 30 Meter, Ring Road, Opposite Ratnakar Tenament, Gotri, Vadodara, 390021, Gujarat, India Experience: 15 Years Occupation: Executive in a Private Company. Qualification: Bachelor of Arts DIN: 02140757	January 20, 2014#	Nil	Nil
6.	Mrs. Shilpa A. Jadeja W/o Mr. Ashoksinh G. Jadeja Age: 43 Years Designation: Non-Executive Independent Director Address: C-7, Anant Park, Near Sabri Vidyalaya, Saiyed Vasna Road, Vadodara, 390015, Gujarat, India Experience: - Nil Occupation: House Wife Qualification: Master of Science DIN: 06696913	January 20, 2014#	Nil	Nil

*Mrs. Sangeeta K. Gupta, who was originally appointed as Director of our Company on incorporation had resigned from Directorship w.e.f. 29.07.2013 due to personal reasons and reappointed as Whole-time Director of our Company w.e.f. 09.01.2014.

Appointed with a liability to retire by rotation. However, in order to comply with the provisions of Companies Act, 2013 changed the terms of appointment by fixing the term of appointment for a period of 5 consecutive years, w.e.f. 14.05.2014, vide Board meeting held on May 14, 2014

Brief Profiles of our Directors

Mr. Kaushalkumar S. Gupta, Chairman & Managing Director

Mr. Kaushalkumar S. Gupta, aged 43 years, is the Chairman cum Managing Director of our Company. He holds a Bachelor Degree in Industrial Engineering from Saurashtra University. He is one of the founder promoters of our Company and our Director since incorporation. He has an overall experience of more than 22 years in various business activities ranging from Trading, Distribution, Manufacturing and Consulting. He has been associated with a reputed MNC and worked in different departments before branching out on his own since 1995 and gathering an experience of around 19 years in the line of business. His main role in the Company is to strategise new business plans with industry trends and consumer preference in mind. He has also lead us for all the technical advancements made by our Company in its products and method of manufacturing.

Mr. Satishkumar S. Gupta, Whole-time Director

Mr. Satishkumar S. Gupta, aged 52 years, is a holder of Diploma in Mechanical Engineering from Technical Examinations Board, Gujarat State. He has also done Certificate Course in Materials Management conducted by Indian Association of Material Management. He has worked in ABB Brown Boveri Limited for more than 19 years since 1980 handling purchase of boughtout's, equipment and components for power plants, before starting business of his own. With an overall experience of more than 33 years to his credit, he provides strategic inputs to the administration for better materials, new designs and development of our Products. He is our Director since incorporation and was appointed as Whole-time Director on July 29, 2013.

Mrs. Sangeeta K. Gupta, Whole-time Director

Mrs. Sangeeta K. Gupta, aged 41 years, is also one of the founder promoters of the Company. She holds a Bachelors degree in Arts (English Entire) from The Maharaja Sayajirao University of Baroda. She is responsible for internal operations and staff support services of our Company. She was originally appointed as Director of the Company on incorporation and was appointed as Whole-time Director of our Company on January 09, 2014.

Ms. Bhavitaben D. Gurjar, Non-Executive-Independent Director

Ms. Bhavitaben D. Gurjar, aged 28 years, is a Non-Executive Independent Director of our Company. She holds a Bachelor’s degree in Commerce from The Maharaja Sayajirao University of Baroda & is currently serving as Head of Operations – Consultancy with Vaathu Associates, Vadodara since last 8 years. As an Independent Director of our Company, she with her finance and corporate acumen, is expected to bring value addition to our Company. She was appointed as an Independent Director of our Company w.e.f. from January 20, 2014.

Mrs. Beena P. Bisht, Non-Executive-Independent Director

Mrs. Beena P. Bisht, aged 38 years, is a Non-Executive Independent Director of our Company. She holds a Bachelor’s degree in Arts from University of Delhi. Currently, she is working as Executive to Managing Director, with Elster-Instromet India Pvt. Ltd., Vadodara. With an experience of more than 15 years working in various Corporates, as an Independent Director of our Company with corporate insightfulness, she contributes professional competency to our Company. She was appointed as an Independent Director of our Company w.e.f. from January 20, 2014.

Mrs. Shilpa A. Jadeja, Non-Executive-Independent Director

Mrs. Shilpa A. Jadeja, aged 43 years, is an Independent Director of our Company. She holds a Master’s degree in Science from Saurashtra University. As an Independent Director of our Company, she is expected to provide our Company with valuable guidance in her sphere of knowledge. She was appointed as an Independent Director of our Company w.e.f. from January 20, 2014.

Nature of any family relationship between our Directors

The present Directors in our Board are related to each other, details of which are as follows:-

Sr. No.	Name of Director	Name of Director and (Relation with Director)
1.	Kaushalkumar S. Gupta	Sangeeta K. Gupta (Wife) Satishkumar S. Gupta (Brother)
2.	Satishkumar S. Gupta	Kaushalkumar S. Gupta (Brother) Sangeeta K. Gupta (Sister in Law)
3.	Sangeeta K. Gupta	Kaushalkumar S. Gupta (Husband) Satishkumar S. Gupta (Brother in Law)

We also confirm that:

- We have not entered into any arrangement or understanding with our major shareholders, customers, suppliers or others, pursuant to which our Directors were appointed as Directors.
- The terms of appointment with our Managing Director/Executive Director(s) do not provide for any benefit upon termination of employment except the retirement benefits as applicable by law.
- None of our Directors is / was a Director in any listed Company, during the last five years from the date of filing of Prospectus, whose shares have been / were suspended from being traded on the BSE Limited and / or National Stock Exchange of India Limited.
- Further, none of our Directors is / was a Director of any listed Company which has been / was delisted from any Recognized Stock Exchange.

Details of Borrowing Powers of Directors

Our Company has passed a special resolution in the Extra Ordinary General Meeting of the members held on January 20, 2014 authorizing the Directors of the Company to borrow from time to time all such money as they may deem necessary for the purpose of business of our Company notwithstanding that money borrowed by the Company together with the monies already borrowed by our Company may exceed the aggregate of the paid up share capital and free reserves

Bansal Roofing Products Limited

provided that the total amount borrowed by the Board of Directors shall not exceed the sum of ₹ 15.00 Crores (Rupees Fifteen Crores only).

Compensation of our Managing Director & Whole-time Director

The compensation payable to our Managing Director and Whole-time Directors will be governed as per the terms of their appointments and shall be subject to the provisions of Sections 196, 197 and 203 read with Schedule V, and all other applicable provisions, if any, of the Companies Act 2013 and applicable provisions of Companies Act, 1956.

The following compensation has been approved for Mr. Kaushalkumar S. Gupta, Managing Director

He was appointed as the Managing Director of our Company w.e.f. July 29, 2013 for 3 years, in the Extra Ordinary General Meeting of the member of our Company held on July 29, 2013 on following terms of remuneration:

Consolidated Salary	₹ 5.40 Lacs per annum including all perquisites Further enhanced to ₹ 12.00 Lac per annum w.e.f. November 01, 2013* Further enhanced to ₹ 18.00 Lac per annum w.e.f. June, 2014**
Amount of compensation paid during the financial year ended 2013	₹ 5.40 Lacs (Rupees Five Lacs Forty Thousand only)
Benefits in kind granted during the financial year ended 2013	Nil
Contingent or deferred compensation accrued for the financial year ended 2013	Nil

*approved and recommended by remuneration committee in its meeting held on October 28, 2013 and subsequently approved by Board of Directors in its meeting held on November 01, 2013.

**approved and re-commended by the Remuneration committee in its meeting held on May 7, 2014 and by Board of Directors in its meeting held on May 14, 2014 and subsequently by remuneration shareholders in their meeting held on May 20, 2014.

No portion of the compensation as mentioned above for Managing Director was paid pursuant to a bonus or profit sharing Plan.

The following compensation has been approved for Mrs. Sangeeta K. Gupta, Whole-time Director

She was appointed as the Whole-time Director of our Company w.e.f. January 9, 2014 following terms of remuneration:

Consolidated Salary	₹ 2.40 Lac per annum including all perquisites w.e.f. January 09, 2014
Amount of compensation paid during the financial year ended 2013	₹ 1.80 Lacs (Rupees One Lacs Eighty Thousand only)
Benefits in kind granted during the financial year ended 2013	Nil
Contingent or deferred compensation accrued for the financial year ended 2013	Nil

No portion of the compensation as mentioned above was paid pursuant to a bonus or profit sharing Plan.

Sitting Fees

The Articles of Association of our Company provides that payment of sitting fees to Directors (other than Managing Director & Whole-time Directors) for attending a meeting of the Board or a Committee thereof shall be such sum as may be prescribed by the Act or the Central government from time to time.

Compensation paid to Directors during the financial year 2012-13

Following is the detail of compensation paid to the Board of Directors of the Company during the F.Y. 2012-13:

Particulars	Salary	Total
Mr. Kaushalkumar S. Gupta	5,40,000.00	5,40,000.00
Mrs. Sangeeta K. Gupta	1,80,000.00	1,80,000.00

(in ₹)

Bansal Roofing Products Limited

Mr. Ashishkumar S. Gupta*	50,000.00	50,000.00
---------------------------	-----------	-----------

* Ceased to be the director w.e.f. 09.01.2014.

Our Independent Directors were appointed on our board post completion of the FY. 2012-13 hence no compensation has been paid to them for the period ended 2013.

Interest of Directors

All the Directors of our Company may be deemed to be interested to the extent of remuneration and/or reimbursement of expenses payable to them as per the applicable laws, and the Articles of Association.

The Directors may also be regarded as interested in the Equity Shares, dividend payable thereon and other distributions in respect of the said Equity Shares, if any, held by or that may be subscribed by and allotted/transferred to them or the companies and firms, in which they are interested as Directors, Members and partners trustees and promoters, pursuant to this Issue. All Directors may be deemed to be interested in the contracts, agreements/arrangements entered into or to be entered into by our Company with any Company in which they hold Directorships.

The Managing Director and Directors of our Company are interested to the extent of remuneration paid to them for services rendered as officer or employee of our Company. Further, the Directors are also interested to the extent of Equity Shares, if any, already held by them or their relatives in our Company. Our Director Mrs. Sangeeta K. Gupta had entered into a Leave & License Agreement dated April 1, 2013 with our Company for the purpose of registered office. The same has been renewed on March 01, 2014 for a total period of 11 months for a monthly rent of ₹ 15,000.00.

Further our Directors are interested in our Company as under:

Sr. No.	Name of Director	Nature of interest
1.	Mrs. Sangeeta K. Gupta	1. Our Director Mrs. Sangeeta K. Gupta has entered into a lease agreement dated April 1, 2013 with our Company for the purpose of registered office. The lease agreement was further renewed for a period of 11 months w.e.f. March 01, 2014. 2. Extended personal guarantee towards the CC limit of ₹ 2.00 Cr. borrowed by the Company.
2.	Mr. Kaushalkumar S. Gupta	1. Owner of Shop no. 1 to 9 B/h. Shivam Hotel, Dabhoi Road, Kapuria Crossing, Vadodara, Gujarat, which has been offered as collateral security against CC limit of ₹ 2.00 Cr. borrowed by the Company and against which equitable mortgage has been created. 2. Extended personal guarantee towards the CC limit of ₹ 2.00 Cr. borrowed by the Company. 3. Provided interest free unsecured loan to the Company to the tune of ₹ 1,42,00,000.00 of which ₹ 82,00,000.00 was outstanding as on May 15, 2014.
3.	Mr. Satishkumar S. Gupta	1. Extended personal guarantee towards the CC limit of ₹ 2.00 Cr. borrowed by the Company.

Further each of the above directors is interested as relatives of each of the aforementioned directors.

Except as stated otherwise in this Prospectus, our Company has not entered into any Contract, Agreements or Arrangements during the preceding two years from the date of the Prospectus in which the Directors are interested directly or indirectly and no payments have been made to them in respect of the contracts, agreements or arrangements which are proposed to be entered into with them.

Except as stated in this section "**Our Management**" or the section titled "**Financial Information of the Company - Related Party Transactions**" beginning on page 93 and 134 respectively of this Prospectus, and except to the extent of shareholding in our Company, our Directors do not have any other interest in our business.

Our Directors have no interest in any property acquired by our Company within two (2) years of the date of this Prospectus.

Common directorships of our Directors in companies whose shares are/were suspended from trading on the BSE and/ or the NSE for a period beginning from five (5) years prior to the date of this Prospectus

None of our Directors are/ were directors of any company whose shares were suspended from trading by Stock Exchange(s) or under any order or directions issued by the stock exchange(s)/ SEBI/ other regulatory authority in the last five (5) years.

None of the Directors are associated with securities market.

Common directorships of our Directors in listed companies that have been/ were delisted from stock exchanges in India

None of our Directors are/ were directors of any entity, whose shares were delisted from any Stock Exchange(s) or which have been debarred from accessing the capital markets under any order or directions issued by the Stock Exchange(s), SEBI or any other Regulatory Authority.

Shareholding of our Directors as on the date of this Prospectus.

Sr. No.	Name of the Director	No. of Shares Held	Holding in %
1.	Mr. Kaushalkumar S. Gupta	9,56,900	63.07
2.	Mrs Sangeeta K. Gupta	3,64,000	23.99
3.	Mr. Satishkumar S. Gupta	1,56,000	10.28
	Total	14,76,900	97.34

Also, none of the Independent Directors of Company holds any Equity Shares of our Company as on the date of this Prospectus.

Changes in Board of Directors in Last 3 Years

Sr. No.	Name	Date of Appointment / Re-appointment / Cessation	Reasons for Change
1.	Mr. Ashishkumar S. Gupta	March 02, 2013	Appointed as Director to broad base the Board
2.	Mr. Kaushalkumar S. Gupta	July 27, 2013	Changed the designation to Chairman & Managing Director
3.	Mr. Satishkumar S. Gupta	July 27, 2013	Changed the designation to Whole-time Director
4.	Mrs. Sangeeta K. Gupta	July 27, 2013	Resignation from directorship of Company
5.	Mr. Ashish Kumar Gupta	July 27, 2013	Changed the designation to Whole-time Director
6.	Mr. Ashishkumar S. Gupta	January 09, 2014	Resignation from directorship of Company
7.	Mrs. Sangeeta K. Gupta	January 09, 2014	Re-appointed as Whole-time Director to broad base the Board
8.	Ms. Bhavitaben D. Gurjar	January 20, 2014	Appointed as Non-Executive Independent Director
9.	Mrs. Beena P. Bisht	January 20, 2014	Appointed as Non-Executive Independent Director
10.	Mrs. Shilpa A. Jadeja	January 20, 2014	Appointed as Non-Executive Independent Director

COMPLIANCE WITH CORPORATE GOVERNANCE

The provisions of the SME Listing Agreement to be entered into with BSE with respect to corporate governance and the SEBI (ICDR) Regulations, 2009 in respect of corporate governance will be applicable to our Company immediately upon the listing of our Company's Equity Shares on the SME Platform of BSE Limited. The Company is in compliance with Corporate Governance Code as per Clause 52 of SME Listing Agreement of BSE. The requirements pertaining to broad basing of the Board of Directors and the constitution of the committees such as the Audit Committee, Shareholder/ Investor Grievance Committee and Remuneration Committees have already been complied with.

Our Board of Directors consists of 6 (Six) directors of which 3 (Three) are Non-Executive Independent Directors (as defined under Clause 52), which constitutes 50% of the Board of Directors, which is in compliance with the requirements of Clause 52. Our Company has already constituted the following committees:

1. Audit Committee

Our Company has formed the Audit Committee vide Resolution passed in the meeting of the Board of Directors dated January 23, 2014. The constituted Audit Committee comprises following members and the committee shall meet at least 4 times a year:

Name of the Director	Status in Committee	Nature of Directorship
Bhavitaben D. Gurjar	Chairman	Non Executive Independent director
Beena P. Bisht	Member	Non Executive Independent director
Satishkumar S. Gupta	Member	Whole time director

The Company Secretary of our Company shall act as a Secretary to the Audit Committee. The Chairman of the Audit Committee shall attend the Annual General Meeting of our Company to furnish clarifications to the shareholders in any matter relating to accounts. The scope and function of the Audit Committee and its terms of reference shall include the following:

A. Tenure: The Audit Committee shall continue to be in function as a committee of the Board until otherwise resolved by the Board, to carry out the functions of the Audit Committee as approved by the Board.

B. Meetings of the Committee: The committee shall meet at least four times in a year and not more than four months shall elapse between any two meetings. The quorum for the meeting shall be either two members or one third of the members of the committee, whichever is higher but there shall be presence of minimum two Independent members at each meeting. Meeting of the Audit Committee shall be called by at least seven day's notice in advance.

C. Role and Powers: The Role of Audit Committee together with its powers shall be as under:

- overseeing the company's financial reporting process and the disclosure of its financial information to ensure that the financial statements are correct, sufficient and credible;
- recommending to the Board, the appointment, re-appointment and, if required, the replacement or removal of the statutory auditor and the fixation of audit fees;
- approving payment to statutory auditors for any other services rendered by the statutory auditors;
- reviewing, with the management, the annual financial statements before submission to the Board for approval, with particular reference to:
 - (a) matters required to be included in the Director's Responsibility Statement to be included in the Board's report in terms of clause (2AA) of Section 217 of the Companies Act;
 - (b) changes, if any, in accounting policies and practices along with reasons for the same;
 - (c) major accounting entries involving estimates based on the exercise of judgment by management;
 - (d) significant adjustments made in the financial statements arising out of audit findings;
 - (e) compliance with listing and other legal requirements relating to financial statements;
 - (f) disclosure of any related party transactions; and
 - (g) qualifications in the draft audit report.
- reviewing, with the management, the quarterly financial statements before submission to the board for approval;
- reviewing, with the management, the statement of uses / application of funds raised through an issue (public issue, rights issue, preferential issue, etc.), the statement of funds utilized for purposes other than those stated in the offer document/prospectus/notice and the report submitted by the monitoring agency monitoring the utilization of proceeds of a public or rights issue, and making appropriate recommendations to the Board to take up steps in this matter;
- reviewing, with the management, performance of statutory and internal auditors, and adequacy of the internal control systems;
- reviewing the adequacy of internal audit function, if any, including the structure of the internal audit department, staffing and seniority of the official heading the department, reporting structure coverage and frequency of internal audit;
- discussing with the internal auditors any significant findings and follow up there on;
- reviewing the findings of any internal investigations by the internal auditors into matters where there is suspected fraud or irregularity or a failure of internal control systems of a material nature and reporting the matter to the Board;
- discussing with the statutory auditors before the audit commences, about the nature and scope of audit as well as post-audit discussion to ascertain any area of concern;
- looking into the reasons for substantial defaults in the payment to the depositors, debenture holders, shareholders (in case of nonpayment of declared dividends) and creditors;
- reviewing the functioning of the Whistle Blower mechanism, in case the same is existing;
- approving the appointment of the Chief Financial Officer (i.e. the whole time finance director or any other person heading the finance function) after assessing the qualifications, experience and background, etc., of the candidate; and
- carrying out any other function as is mentioned in the terms of reference of the Audit Committee or contained in

the equity listing agreements as and when amended from time to time.

Further, the Audit Committee shall mandatorily review the following:

- management discussion and analysis of financial condition and results of operations;
- statement of significant related party transactions (as defined by the Audit Committee), submitted by management;
- management letters / letters of internal control weaknesses issued by the statutory auditors;
- internal audit reports relating to internal control weaknesses; and
- the appointment, removal and terms of remuneration of the chief internal auditor.

2. Shareholder's / Investors Grievance Committee

Our Company has formed the Shareholders / Investors Grievance Committee vide Resolution passed in the meeting of the Board of Directors dated January 23, 2014. The constituted Shareholders / Investors Grievance Committee comprises following the Chairman and members:

Name of the Director	Status in Committee	Nature of Directorship
Beena P. Bisht	Chairman	Non Executive Independent director
Shilpa A. Jadeja	Member	Non Executive Independent director
Kaushalkumar S. Gupta	Member	Whole time director

The Company Secretary of our Company shall act as a Secretary to the Shareholders / Investors Grievance Committee. The scope and function of the Shareholders / Investors Grievance Committee and its terms of reference shall include the following:

A. Tenure & Meetings: The Shareholders'/Investors' Grievance Committee shall meet at least at least four times a year with maximum interval of four months between two meetings and shall report to the Board on a quarterly basis regarding the status of redressal of complaints received from the shareholders of the Company. The quorum shall be two members present.

B. Terms of Reference: Redressal of shareholders' and investors' complaints, including and in respect of:

- Allotment, transfer of shares including transmission, splitting of shares, changing joint holding into single holding and vice versa, issue of duplicate shares in lieu of those torn, destroyed, lost or defaced or where the cages in the reverse for recording transfers have been fully utilized.
- Issue of duplicate certificates and new certificates on split/consolidation/renewal, etc.; and
- Review the process and mechanism of redressal of Shareholders /Investors grievance and suggest measures of improving the system of redressal of Shareholders /Investors grievances.
- Non-receipt of share certificate(s), non-receipt of declared dividends, non-receipt of interest/dividend warrants, non-receipt of annual report and any other grievance/complaints with Company or any officer of the Company arising out in discharge of his duties.
- Oversee the performance of the Registrar & Share Transfer Agent and also review and take note of complaints directly received and resolved them.
- Oversee the implementation and compliance of the Code of Conduct adopted by the Company for prevention of Insider Trading for Listed Companies as specified in the Securities & Exchange Board of India (Prohibition of insider Trading) Regulations, 1992 as amended from time to time.
- Any other power specifically assigned by the Board of Directors of the Company from time to time by way of resolution passed by it in a duly conducted Meeting,
- Carrying out any other function contained in the equity listing agreements as and when amended from time to time.

3. Nomination & Remuneration/ Compensation Committee

The remuneration committee was constituted vide board resolution dated October 21, 2013. Later Our Company has re-constituted the Remuneration/Compensation Committee as Nomination and Remuneration Committee, vide Resolution passed in the meeting of the Board of Directors dated January 23, 2014. The re-constituted Nomination and Remuneration/Compensation Committee comprises following Chairman and the members.

Name of the Director	Status in Committee	Nature of Directorship
Shilpa A. Jadeja	Chairman	Non Executive Independent director
Beena P. Bisht	Member	Non Executive Independent director
Bhavitaben D. Gurjar	Member	Non Executive Independent director

The Company Secretary of our Company shall act as a Secretary to the Remuneration Committee. The scope and function of the Committee and its terms of reference shall include the following:

A. Tenure: The Remuneration Committee shall continue to be in function as a committee of the Board until otherwise resolved by the Board.

B. Meetings:

The committee shall meet as and when the need arise for review of Managerial Remuneration. The quorum for the meeting shall be one third of the total strength of the committee or two members, whichever is higher. Meeting of the Remuneration Committee shall be called by at least seven day’s notice in advance.

C. Terms of Reference:

- a) Identify persons who are qualified to become directors and may be appointed in senior management in accordance with the criteria laid down, recommend to the Board their appointment and removal and shall carry out evaluations of every director’s performance.
- b) Formulate the criteria for determining the qualifications, positive attributes and independence of a director and recommend to the Board a policy, relating to the remuneration for directors, KMPs and other employees.
- c) Decide the salary, allowances, perquisites, bonuses, notice period, severance fees and increment of Executive Directors.
- d) Define and implement the Performance Linked Incentive Scheme (including ESOP of the Company) and evaluate the performance and determine the amount of incentive of the Executive Directors for that purpose.
- e) Decide the amount of Commission payable to the Whole time Directors.
- f) Review and suggest revision of the total remuneration package of the Executive Directors keeping in view the performance of the Company, standards prevailing in the industry, statutory guidelines etc.
- g) To formulate and administer the Employee Stock Option Scheme.

Policy on Disclosures and Internal Procedure for Prevention of Insider Trading

The provisions of Regulation 12(1) of the SEBI (Prohibition of Insider Trading) Regulations, 1992 will be applicable to our Company immediately upon the listing of its Equity Shares on the SME Platform of BSE Limited. We shall comply with the requirements of the SEBI (Prohibition of Insider Trading) Regulations, 1992 on listing of Equity Shares on stock exchanges. Further, Board of Directors have approved and adopted the policy on insider trading in view of the proposed public issue.

Ms. Harneetkaur S. Anand, Compliance Officer will be responsible for setting forth policies, procedures, monitoring and adherence to the rules for the preservation of price sensitive information and the implementation of the Code of Conduct under the overall supervision of the Board.

Our Organisation Chart

The following chart depicts our Management Organization Structure:

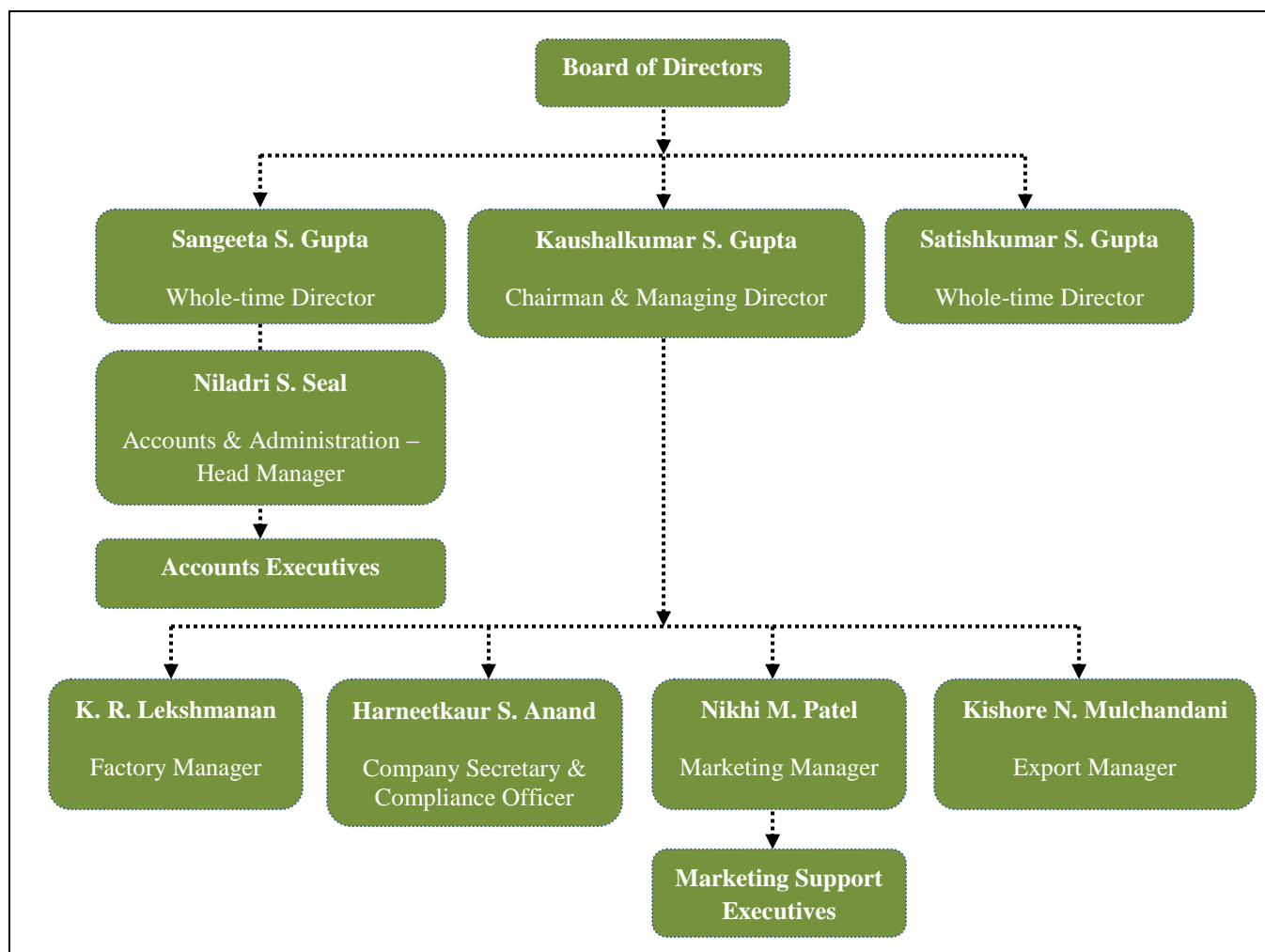

Key Managerial Personnel

Our Company is supported by a team of experts and professionals having exposure to various operational aspects of our business. A brief detail about the Key Managerial Personnel of our Company is provided below:

Name, Designation & Educational Qualification	Age	Date of joining / Transfer	Compensation paid for F.Y. ended 2013 (in ₹)	Overall experience	Previous employment
Mr. Niladri S. Seal Designation: Accounts & Administration – Head Manager Educational Qualification: Bachelor of Commerce	40 Years	July 1, 2013	Not Applicable	17 Years	Agrawal Associates*
Mr. Nikhil M. Patel Designation: Marketing Manager Educational Qualification: Master of Commerce	37 Years	July 1, 2013	Not Applicable	12 Years	Agrawal Associates*
Ms. Harneetkaur S. Anand Designation: Company Secretary and Compliance Officer Educational Qualification: Company Secretary	22 Years	July 8, 2013	Not Applicable	-	-
Mr. Kishore N. Moolchandani Designation: Export Manager Educational Qualification: Bachelor of	55 Years	July 8, 2013	Not Applicable	30 Years	Desai Construction

Bansal Roofing Products Limited

Commerce					
Mr. K. R. Lekshmanan Designation: Factory Manager Educational Qualification: Bachelor of Arts	51 Years	February 24, 2014	Not Applicable	20 Years	Spaco Carburettors India Pvt. Ltd

*Proprietorship concern of Mr. Kaushalkumar S. Gupta, one of our promoter and Managing Director cum Chairman.

BRIEF PROFILE OF KEY MANAGERIAL PERSONNEL

Mr. Niladri S. Seal, Accounts & Administration – Head Manager

Mr. Niladri S. Seal, aged 40 years, he is in charge of Accounts and Administration of our company. He takes care of the overall finance function and office administrative functions of the Company. He holds a Bachelor's degree in Commerce from University of Calcutta. He has over 17 years of experience in his functional area. Prior to joining our company, he was associated with Agrawal Associates, one of our group entities.

Mr. Nikhil M. Patel, Marketing Manager

Mr. Nikhil M. Patel, aged 37 years, supervises the marketing division our Company. He commands rich knowledge in his area of operation and is involved in forming marketing strategy of our Company and implementation of the same. He joined our Company on July 1, 2013. Prior to joining our company, he was associated with Agrawal Associates, one of our group entities.

Ms. Harneetkaur S. Anand, Company Secretary and Compliance Officer

Ms. Harneetkaur S. Anand, aged 22 years, is the Company Secretary and Compliance Officer of our Company. She has qualified her Company Secretary course from the Institute of Company Secretaries of India and holds a Bachelor's degree in Commerce from The Maharaja Sayajirao University of Baroda. Prior to joining our Company, she completed her management training with Samdani Kabra & Associates, Practicing Company Secretaries, Vadodara. At present, she looks after the secretarial matters of our Company. She joined our Company on July 8, 2013. Our Company benefits from her knowledge on secretarial and corporate matters.

Mr. Kishore N. Mulchandani, Export Manager

Mr. Kishore N. Mulchandani, aged 55 years, holds the position of Export Manger of our Company. He holds Bachelor's degree in Commerce from Gujarat University. He is responsible for the exploring new markets and administration of International Business for our products. Our Company benefits from his wide and rich experience of 30 years of experience in his domain of operation. Prior to joining our company, he was associated with Desai Construction.

Mr. K. R. Lekshmanan, Factory Manager

Mr. K. R. Lekshmanan, aged 51 years, is Factory Manager of our Company. He holds Bachelor's degree in Arts from Indira Gandhi National Open University. He looks after the overall functions which are being carried out at our factory. He has over 20 years of experience in his functional area. Prior to joining our company, he was associated with Spaco Carburettors India Pvt. Ltd.

We confirm that:

- All the persons named as our Key Managerial Personnel above are the permanent employees of our Company.
- There is no understanding with major shareholders, customers, suppliers or any others pursuant to which any of the above mentioned Key Managerial Personnel have been recruited.
- None of our KMPs are related to our Promoter or our Directors.
- None of the above mentioned Key Managerial Personnel are related to each other.
- In respect of all above mentioned Key Managerial Personnel there has been no contingent or deferred compensation accrued for the year ended March 2013.
- Except for the terms set forth in the appointment letters, the Key Managerial Personnel have not entered into any other contractual arrangements or service contracts (including retirement and termination benefits) with the issuer.
- Our Company does not have any bonus/profit sharing plan for any of the Key Managerial Personnel.
- Other than Mr. Niladri S. Seal and Mr. Nikhil M. Patel, who holds 13,000 equity shares of our Company each, none of the Key Managerial Personnel in our Company hold any shares of our Company as on the date of filing of this Prospectus.

Bansal Roofing Products Limited

- i. Presently, we do not have ESOP/ESPS scheme for our employees.
- j. The turnover of KMPs is not high, compared to the Industry to which our belongs.

Changes in the Key Managerial Personnel in last three years:

There have been no changes in the Key Managerial Personnel of our Company during the last 3 (three) year except as stated below:

Sr. No.	Name	Designation	Date of Appointment/Cessation/Promotion/Transfer	Reasons
1.	Mr. Niladri S. Seal	Accounts & Administration – Head Manager	July 1, 2013	Appointment
2.	Mr. Nikhil M. Patel	Marketing Manager	July 1, 2013	Appointment
3.	Ms. Harneetkaur S. Anand	Company Secretary & Compliance Officer	July 8, 2013	Appointment
4.	Mr. Kishore N. Mulchandani	Export Manager	July 8, 2013	Appointment
5.	Mr. K. R Lekshmanan	Factory Manager	February 24, 2014	Appointment

Interest of Our Key Managerial Persons

Name	Nature of Interest
Mr. Niladri S. Seal	Holds 13,000 Equity Shares of Our Company.
Mr. Nikhil M. Patel	Holds 13,000 Equity Shares of Our Company.

Payment of Benefits to Officers of our Company (*non-salary related*)

Except for any statutory payments made by our Company upon termination of services of its officer or employees, our Company has not paid any sum, any non-salary amount or benefit to any of its officers or to its employees including amounts towards super-annuation, ex-gratia/rewards.

OUR PROMOTERS

	Mr. Kaushalkumar S. Gupta – Chairman & Managing Director	
	Qualification	Bachelor of Engineering (Industrial) from Saurashtra University
	Age	43 Years
	Address	C- 45, Shreedharpark Society, Opposite Novino Batteries, Makarpura Road, Vadodara, 390010, Gujarat, India
	Experience	22 Years
	Occupation	Business
	Permanent Account Number	ABPPG1930R
	Passport Number	F2096752
	Name of Bank & Bank Account Details	HDFC Bank Ltd., Arun Complex, 36, Alkapuri Society, R C Dutt Road, Vadodara, Gujarat, 390 007 Bank Account No: 00331930002270
	Driving License Number	21993/GDR
	Voter Identification Card Number	GJ/22/147/525711
	No. of Equity Shares held in BRPL & [% of Shareholding (Pre Issue)]	9,56,900 Equity Shares [63.07 %]
	Other Interests	Other Directorships:- Nil Partnership Firms:- Nil Proprietorship Firm:- Agrawal Associates HUF:- Kaushalkumar S Gupta HUF (Karta)
	Mrs. Sangeeta K. Gupta – Whole-time Director	
	Qualification	Master of Arts (English Entire) from The Maharaja Sayajirao University of Baroda.
	Age	41 Years
	Address	C- 45, Shreedharpark Society, Opposite Novino Batteries, Makarpura Road, Vadodara, 390010, Gujarat, India
	Experience	5 Years
	Occupation	Business
	Permanent Account Number	AKEPG7134P
	Passport Number	F1919461
	Name of Bank & Bank Account Details	HDFC Bank Ltd., Arun Complex, 36, Alkapuri Society, R C Dutt Road, Vadodara, Gujarat, 390 007 Bank Account No: 00331930000214
	Driving License Number	GJ-06-VD/2008/57667
	Voter Identification Card Number	GJ/22/147/478019
	No. of Equity Shares held in BRPL & [% of Shareholding (Pre Issue)]	3,64,000 Equity Shares [23.99 %]
	Other Interests	Other Directorships:- Nil Partnership Firms:- Nil Proprietorship Firm:- Bansal Roofing Products HUF:- Kaushalkumar S Gupta HUF (Member)

We confirm that the Permanent Account Number, Bank Account Number and Passport Number of the above Promoter have been submitted to Bombay Stock Exchange Limited at the time of filing of this Prospectus with them.

Confirmations from our Promoters

Our Promoters have confirmed that they have not been declared as wilful defaulter by RBI or any other government authority and there are no violations of securities laws committed by our Promoters in the past, nor any such proceedings are pending against our Promoters. Our Promoters has further confirmed that they have not been prohibited or debarred from accessing or operating in the capital markets for any reasons, or restrained from buying, selling or dealing in securities, under any order or directions made by SEBI or any other authorities and that no action has been taken against them or any entity promoted or controlled by them by any regulatory authorities.

Common Pursuits

Our Promoters have interest in our Promoter Group entities viz. Agrawal Associates (**Proprietorship Firm**), Bansal Roofing Products (**Proprietorship Firm**) which are engaged in the line of business similar to our Company. As on the date of this Prospectus, we cannot assure that our Promoters will not favour the interests of the said entities over our interest or that the said entities will not expand their businesses which may increase our chances of facing competition. This may adversely affect the business operations and financial condition of our Company. For further details, please see “Risk Factors” on page 11. For details of our Promoter Group and Group Company refer to Section titled “**Our Promoter Group & Promoter Group Entities**” on page 108 of the Prospectus.

We shall adopt the necessary procedures and practices as permitted by law to address any conflicting situations, as and when they may arise.

Interest of Promoters

Our Promoters Mr. Kaushalkumar S. Gupta and Mrs. Sangeeta K. Gupta are interested to the extent of their shareholding in our Company and also as the Executive Directors of our Company may be deemed to be interested to the extent of remuneration, as per the terms of their appointment.

Further they may be deemed to be interested in our Company to the extent of transactions carried on by our Company with the proprietorship concerns of the promoters. For further details, please refer to section titled “**Related Party Transactions**” on page 134 and “**Interest of Directors**” on page 97 of this Prospectus.

Interest in the property of Our Company

Except our registered office which is taken on rent from our promoter Mrs. Sangeeta K. Gupta vide agreement dated April 1, 2013 for 11 months which was renewed for further 11 months on March 1, 2014, Our Promoters do not have any other interest in any property acquired by our Company in a period of two years before filing of this Prospectus or proposed to be acquired by us as on date of filing the Prospectus with ROC.

Related Party Transactions

For the transactions with our Promoter Group entities, please refer to section titled “**Related Party Transactions**” on page 134 of this Prospectus.

Except as stated in “**Related Party Transactions**” beginning on page 134 of the Prospectus, and as stated therein, our Promoter or any of the Promoter Group Entities do not have any other interest in our business.

Payment or Benefit to Promoters of Our Company

For details of payments or benefits paid to our Promoters, please refer to the paragraph “**Compensation of our Managing Director and Whole-time Director**” in the chapter titled “**Our Management**” and “**Capital Structure**” on page 96 and 39 respectively. Also refer Annexure- N on “**Related Party Transactions**” on page 134 forming part of “**Financial Information of the Company**” and Paragraph on “**Interest of Promoters**” on page 106 of this Prospectus.

Interest of Promoter in our Company Other than as Promoter

Except as mentioned in this section and the sections titled “**Our Business**”, “**History and Corporate Structure**”, “**Financial Indebtedness**” and “**Financial Information – Related Party Transactions**” on pages 72, 90, 140 and 134, respectively, our Promoter does not have any interest in our Company other than as Promoter.

Companies / Firms from which the Promoter has disassociated in last 3 (three) years

Our Promoters have not disassociated themselves from any of the companies, firms or other entities during the last three years preceding the date of this Prospectus.

Other ventures of our Promoters

Save and except as disclosed in the section titled “*Our Promoters*” and “*Our Promoter Group & Promoter Group Entities*” beginning on page 105 & 108 respectively of this Prospectus, there are no ventures promoted by our Promoter in which they have any business interests/other interests.

Litigation details pertaining to our Promoters

For details on litigations and disputes pending against the Promoter and defaults made by the Promoter please refer to the section titled “*Outstanding Litigations and Material Developments*” beginning on page 151 of this Prospectus.

OUR PROMOTER GROUP AND PROMOTER GROUP ENTITIES

In addition to the Promoters named above, the following natural persons are part of our Promoter Group in terms of Regulation 2(1)(zb) of SEBI ICDR Regulations:

Relationship	Mr. Kaushalkumar S. Gupta	Mrs. Sangeeta S. Gupta
Father	Mr. Satyanarayan R. Gupta	Mr. Jatanlal L. Mittal
Mother	Late Mrs. Vidya S. Gupta	Mrs. Munnidevi J. Mittal
Spouse	Mrs. Sangeeta K. Gupta	Mr. Kaushalkumar S. Gupta
Brother	Mr. Satishkumar S. Gupta Mr. Jayprakash S. Gupta	Mr. Mahesh J. Mittal
Sister	Mrs. Nirmala S. Agrawal	Mrs. Vinita Sharma
Son	Master Kailash K. Gupta Master Jignesh K. Gupta	Master Kailash K. Gupta Master Jignesh K. Gupta
Daughter	-	-
Spouse's Father	Mr. Jatanlal L. Mittal	Mr. Satyanarayan R. Gupta
Spouse's Mother	Mrs. Munnidevi J. Mittal	Late Mrs. Vidya S. Gupta
Spouse's Brother	Mr. Mahesh J. Mittal	Mr. Satishkumar S. Gupta Mr. Jayprakash S. Gupta
Spouse's Sister	Mrs. Vinita Sharma	Mrs. Nirmala S. Agrawal

Our Promoter Group as defined under Regulation 2 (zb) of the SEBI (ICDR) Regulations, 2009 includes following entities:

Nature of Relationship	Entity
Any body corporate in which 10 (Ten) percent or more of the equity share capital is held by the promoter or an immediate relative of the promoter or a firm or HUF in which the promoter or any one or more of his immediate relative is a member.	None
Any Body corporate in which a body corporate as provided above holds 10 (Ten) percent or more of the equity share capital	None
Any HUF or firm in which the aggregate shareholding of the promoter and his immediate relatives is equal to or more than 10 (Ten) percent of the total	1. Kaushalkumar S Gupta HUF 2. Agrawal Associates (Proprietor: Mr. Kaushalkumar S. Gupta) 3. Bansal Roofing Products (Proprietor: Mrs. Sangeeta K. Gupta) 4. Satishkumar S Gupta (HUF) 5. Ashinishi Mktg. & Engg. Co. (Proprietor: Mr. Satishkumar S. Gupta) 6. Ashu Auto Spares (Proprietor: Mr. Jayprakash S. Gupta)

Details of Our Promoter Group Entities

HINDU UNDIVIDED FAMILIES (HUF's)

Kaushalkumar S Gupta HUF

Kaushalkumar S Gupta HUF is a Hindu un-divided family and was formed on March 02, 2012. Mr. Kaushalkumar S Gupta is the Karta of the HUF.

Details of HUF

Name of HUF and PAN	Name of Karta	Member of HUF
Kaushalkumar S Gupta HUF AAJHK6248M	Mr. Kaushalkumar S. Gupta	Mr. Kaushalkumar S. Gupta Mrs. Sangeeta K. Gupta Master Kailash K. Gupta Master Jignesh K. Gupta

Financial Performance

There is no financial activity under the name of Kaushalkumar S Gupta HUF.

Satishkumar S Gupta (HUF)

Satishkumar S Gupta (HUF) is a Hindu un-divided family and was formed on September 01, 2012. Mr. Satishkumar S Gupta is the Karta of the HUF.

Details of HUF

Name of HUF and PAN	Name of Karta	Member of HUF
Satishkumar S Gupta (HUF) AAXHS6843Q	Mr. Satishkumar S. Gupta	Mr. Satishkumar S. Gupta Mrs. Shakuntala S. Gupta Mr. Ashishkumar S. Gupta Mr. Nidhish S. Gupta

Financial Performance

(₹ in Lacs)

Sr. No.	Particulars	as at March 31,		
		2013	2012	2011
1.	Capital	2.32	Not Applicable	Not Applicable
2.	Net Profit / (Loss) for the year	3.06	Not Applicable	Not Applicable

PROPRIETORSHIP FIRMS

Agrawal Associates

“Agrawal Associates” is proprietorship firm of one of our promoter Mr. Kaushalkumar S. Gupta. The firm commenced its business in 2002 and is mainly engaged in the business of Manufacturing and Trading in FRP Roofing Sheets & Turbo Ventilators and Trading of Colour Coated Metal sheets. It also takes job work for roofing activities.

Financial Performance

(₹ in Lacs)

Particulars	For the year ending March 31,		
	2013	2012	2011
Proprietor’s Capital as at	186.72	279.44	205.95
Total Income	2233.26	2567.87	1629.88
Net Profit / (Loss)	89.58	145.77	117.80

Bansal Roofing Products

“Bansal Roofing Products” is proprietorship firm of one of our promoter Mrs. Sangeeta K. Gupta. The firm commenced its business in the year 2008 and is engaged in the trading of building material and doing job work for building and roofing activities.

Financial Performance

(₹ in Lacs)

Particulars	For the year ending March 31,		
	2013	2012	2011
Proprietor’s Capital as at	0.76	2.13	2.00
Total Income	4.50	3.06	2.42
Net Profit / (Loss)	0.63	0.14	0.09

Ashinishi Mktg. & Engg. Co.

“Ashinishi Mktg. & Engg. Co.” is proprietorship firm of one of our promoter group member Mr. Satishkumar S. Gupta. The firm commenced its business in the year 1994 and is engaged in the trading in building materials.

Financial Performance

(₹ in Lacs)

Particulars	For the year ending March 31,		
	2013	2012	2011
Proprietor’s Capital as at	19.77	22.57	19.15
Total Income	89.88	86.48	72.29
Net Profit / (Loss)	8.54	7.52	6.44

Ashu Auto Spares

“Ashu Auto Spares” is proprietorship firm of one of our promoter group member Mr. Jayprakash S. Gupta. The firm commenced its business in the year 2002 and is engaged in the trading of spares parts for automobiles.

Financial Performance

(₹ in Lacs)

Particulars	For the year ending March 31,		
	2013	2012	2011
Proprietor’s Capital as at	22.84	17.91	15.64
Total Income	21.49	22.82	19.15
Net Profit / (Loss)	2.94	3.26	2.61

Litigations

For details on litigations and disputes pending against the Group Entities, if any, please refer to the section titled “*Outstanding Litigations and Material Developments*” on page 151 of the Prospectus.

Undertaking / confirmations

Our Promoters and Group Entities confirm that they have not been declared as a willful defaulter by the RBI or any other governmental authority and there have been no violations of securities laws committed by them or any entities they are connected with in the past and no proceedings pertaining to such penalties are pending against them.

None of the Promoters or Promoter Group or Group Entities or persons in control of the Promoters has been

- (i) prohibited from accessing the capital market under any order or direction passed by SEBI or any other authority or
- (ii) Refused listing of any of the securities issued by such entity by any stock exchange, in India or abroad.

None of the Promoters is or has ever been a promoter, director or person in control of any other Company which is debarred from accessing the capital markets under any order or direction passed by the SEBI.

Common Pursuits/Conflict of Interest

Our Promoters have interest in our Promoter Group entities viz. Agrawal Associates, Bansal Roofing Products which are engaged in the line of business similar to our Company. As on the date of this Prospectus, we cannot assure that our Promoters will not favor the interests of the said entities over our interest or that the said entities will not expand their businesses which may increase our chances of facing competition. This may adversely affect our business operations and financial condition of our Company.

We shall adopt the necessary procedures and practices as permitted by law to address any conflicting situations, as and when they may arise.

Related business transaction within the Group and their significance on the financial performance of the issuer:

For details relating to the business transactions within the Group entities and their significance on the financial performance of the issuer see the chapter titled “*Financial Information of the Company - Related Party Disclosures*” on page 134 of the Prospectus.

Sales / Purchase between our Company and Group Entities:

For details relating to sales or purchases between our Company and any of our Group entities exceeding 10% of the sales or purchases of our Company see the chapter titled “*Financial Information of the Company - Related Party Disclosures*” on page 134 of the Prospectus.

DIVIDEND POLICY

Under the Companies Act, our Company can pay dividends upon a recommendation by our Board of Directors and approval by the shareholders at the general meeting of our Company. The Articles of Association of our Company give our shareholders, the right to decrease, and not to increase, the amount of dividend recommended by the Board of Directors. The Articles of Association of our Company also gives the discretion to our Board of Directors to declare and pay interim dividends. No dividend shall be payable for any financial except out of profits of our Company for that year or that of any previous financial year or years, which shall be arrived at after providing for depreciation in accordance with the provisions of Companies Act, 2013.

Our Company does not have any formal dividend policy for declaration of dividend in respect of the Equity Shares. The declaration and payment of dividend will be recommended by our Board of Directors and approved by the shareholders of our Company at their discretion and may depend on a number of factors, including the results of operations, earnings, Company's future expansion plans, capital requirements and surplus, general financial condition, contractual restrictions, applicable Indian legal restrictions and other factors considered relevant by our Board of Directors.

Our Company has not declared any dividend on the Equity Shares in the past five financial years. Our Company's corporate actions pertaining to payment of dividends in the past are not to be taken as being indicative of the payment of dividends by our Company in the future.

SECTION V: FINANCIAL INFORMATION OF THE COMPANY

RESTATED FINANCIAL STATEMENTS OF THE COMPANY

INDEPENDENT AUDITOR'S REPORT ON RESTATED FINANCIAL STATEMENTS

(As required by Part II of Schedule II to the Companies Act, 1956)

To,
The Board of Directors,
Bansal Roofing Products Limited
3/2, Labdhi Industrial Estate,
Acid Mill Compound, Ranmukteshwar Road,
Pratapnagar, Vadodara – 390004,
Gujarat, India

Dear Sir(s),

We have examined the restated financial accounts of Bansal Roofing Products Limited (hereinafter referred as “the Company”), the summarized statements of which annexed to this report have been prepared in accordance with the requirements of:

- i) Paragraph B(1) of Part II of Schedule II to the Companies Act, 1956 (the Act);
- ii) The Securities and Exchange Board of India (Issue of Capital and Disclosure Requirements) Regulations, 2009 (the Regulation) issued by the Securities and Exchange Board of India (SEBI) and amendments made thereto from time to time in pursuance of section 11 of the Securities and Exchange Board of India Act, 1992; and
- iii) The instructions received from the Company, requesting to examine the financial information referred to above and proposed to be included in the Draft Offer Document / Offer Document of the Company in connection with its proposed initial public offer of equity shares.
- iv) The (Revised) Guidance Note on Reports in Company Prospectuses issued by the Institute of Chartered Accountants of India (‘ICAI’)

Audit of the financial statements for the 9 months period ended December 31, 2013 and years ended March 31, 2013, 2012, 2011, 2010 & 2009 have been conducted by Company’s Statutory Auditor M/s. Santlal Patel & Co., Chartered Accountants. Further, Financial Statements for 9 months period ended December 31, 2013 and year ended March 31, 2013 has been re-audited by us as required under the SEBI ICDR Regulations. This report, in so far as it relates to the amounts included for the financial years ended March 31, 2012, 2011, 2010 & 2009 is based on the Audited Financial Statements of the Company which were audited by the Statutory Auditor, M/s. Santlal Patel & Co., Chartered Accountants and whose Auditor’s Reports have been relied upon by us for the said periods.

Financial Information of the Company:

1. We have examined the attached Restated Statement of Assets and Liabilities of the Company as at December 31, 2013, March 31, 2013, 2012, 2011, 2010 and 2009 (Annexure-I); the accompanying Restated Statement of Profit and Losses of the Company for the 9 months period ended December 31, 2013 and years ended March 31, 2013, 2012, 2011, 2010 & 2009 (Annexure-II); the accompanying Restated Statement of Cash Flows of the Company for the 9 months period ended December 31, 2013 and years ended March 31, 2013, 2012, 2011, 2010 & 2009 (Annexure-III) and the significant accounting policies and notes to restated financial statements (Annexure IV) together referred to as ‘Summary Statements’ as prepared by the Company and approved by the Board of Directors.
2. Based on the examination of these Summary Statements, we confirm that the restated profits and losses have been arrived at after charging all expenses including depreciation and after making such adjustments and regrouping as in our opinion are appropriate.
3. We have examined the following regrouped/ rearranged financial information relating to the Company, proposed to be included in the Draft Prospectus / Prospectus, as approved by the Board of Directors of the Company and attached to this report:
 - Statement of Fixed Assets (Annexure A);
 - Statement of Non Current Investments (Annexure B);
 - Statement of Long-Term Loans and Advances (Annexure C);

- Statement of Trade Receivables (Annexure D);
- Statement of Cash and Cash Equivalents (Annexure E);
- Statement of Short-Term Loans and Advances (Annexure F);
- Statement of Other Current Assets (Annexure G);
- Statement of Share Capital, Reserves and Surplus (Annexure H);
- Statement of Long Term and Short Term Borrowings (Annexure I);
- Statement of Principal Terms of Secured Loans and Assets Charged as Security (Annexure I (A));
- Statement of Terms & Conditions of Unsecured Loans (Annexure I (B));
- Statement of Deferred Tax (Assets)/Liabilities (Annexure J)
- Statement of Trade Payables (Annexure K);
- Statement of Other Current Liabilities and Short-Term Provisions (Annexure L);
- Statement of Other Income (Annexure M);
- Statement of Related Party Transaction (Annexure N);
- Statement of Capitalisation (Annexure O);
- Summary of Mandatory Accounting Ratios (Annexure P);
- Statement of Tax Shelter (Annexure Q);

Auditor's Responsibility

Our responsibility is to express an opinion on these restated financial statements based on our audit. We conducted our audit in accordance with the Standards on Auditing issued by the Institute of Chartered Accountants of India. Those Standards require that we comply with ethical requirements and plan and perform the audit to obtain reasonable assurance about whether the financial statements are free from material misstatement.

An audit involves performing procedures to obtain audit evidence about the amounts and disclosures in the financial statements. The procedures selected depend on the auditor's judgment, including the assessment of the risks of material misstatement of the financial statements, whether due to fraud or error.

In making those risk assessments, the auditor considers internal control relevant to the Company's preparation and fair presentation of the financial statements in order to design audit procedures that are appropriate in the circumstances. An audit also includes evaluating the appropriateness of accounting policies used and the reasonableness of the accounting estimates made by management, as well as evaluating the overall presentation of the financial statements.

We believe that the audit evidence we have obtained is sufficient and appropriate to provide a basis for our audit opinion.

Opinion

In our opinion and to the best of our information and according to the explanations given to us, the restated financial statements read together with the notes thereon, give the information required by the Act in the manner so required and give a true and fair view in conformity with the accounting principles generally accepted in India, to the extent applicable;

- (a) In the case of the Statement of Assets and Liabilities of the Company as at December 31, 2013, March 31, 2013, 2012, 2011, 2010 and 2009;
- (b) In the case of the Statement of Profit and Loss, of the profit of the Company for the period/years ended on that date;
- (c) In the case of the Cash Flow Statement, of the cash flows of the Company for the years/period ended on that date.

This report is intended solely for your information and for the inclusion in the Offer Document in connection with the proposed initial public offer of the Company and is not to be used, referred to or distributed for any other purpose without my prior written consent.

For V. J. Amin & Co.
Chartered Accountants
FRN: 100335W

Sd/-
CA. Vipul M. Dalal
Partner
Membership No. 103667
Place: Vadodara
Date: May 21, 2014

ANNEXURE - I

RESTATED STATEMENT OF ASSETS AND LIABILITIES

(Amt in ₹)

Particulars	As at					
	31-12-13	31-03-13	31-03-12	31-03-11	31-03-10	31-03-09
I. EQUITY AND LIABILITIES						
Shareholder's Funds						
Share Capital	10000000.00	10000000.00	1000000.00	100000.00	100000.00	100000.00
Reserves and Surplus	9191897.40	6112017.47	(301930.32)	285260.75	214001.79	126830.08
Non Current Liabilities						
Long-term Borrowings	8317392.67	14414860.97	14200000.00	700000.00	0.00	0.00
Deferred Tax Liabilities (Net)	758826.88	506459.89	82244.14	8038.98	6162.65	3696.83
Long-term Provisions	0.00	0.00	0.00	0.00	0.00	0.00
Current Liabilities						
Short-term Borrowings	6050931.85	3396113.00	0.00	0.00	0.00	80000.00
Trade Payables	15496812.10	22989766.65	5956995.15	102562.00	139131.00	195027.87
Other Current Liabilities	5514446.00	699915.00	54729.00	36515.00	53019.00	0.00
Short-term Provisions	1556334.00	2306467.00	37877.00	32916.00	36515.00	53019.00
Total	56886640.90	60425599.98	21029914.97	1265292.73	548829.44	558573.78
II. Assets						
Non Current Assets						
Fixed assets	16471172.19	14770950.44	13785868.35	87275.10	92013.23	96751.35
Non Current Investments	0.00	0.00	0.00	0.00	0.00	0.00
Long-term Loans and Advances	43944.00	41544.00	41544.00	0.00	0.00	0.00
Other Non Current Assets	0.00	0.00	0.00	0.00	0.00	0.00
Current assets						
Current Investments	0.00	0.00	0.00	0.00	0.00	0.00
Inventories	23755895.06	22228963.84	4244096.00	0.00	0.00	0.00
Trade Receivables	3047743.00	19580877.00	744902.00	349073.90	264170.90	277808.90
Cash and Cash Equivalents	3861541.26	460891.78	564484.81	712517.56	99236.31	157379.53
Short-term Loans and Advances	4617619.98	155370.63	338938.00	0.00	0.00	0.00
Other Current Assets	5088725.41	3187002.29	1310081.81	116426.17	93409.00	26634.00
Total	56886640.90	60425599.98	21029914.97	1265292.73	548829.44	558573.78

Note: The above statement should be read with the significant accounting policies and notes to restated summary statements, restated statement of profit and loss and restated cash flow statement as appearing in Annexures IV, II and III.

ANNEXURE - II
RESTATED STATEMENT OF PROFIT AND LOSS

(Amt. in ₹)

Particulars	For 9 months period ended	For the Year ended				
	31-12-13	31-03-13	31-03-12	31-03-11	31-03-10	31-03-09
Revenue from Operations	141157650.29	171550783.37	7084759.11	672794.80	448638.00	458816.40
Other income	6562.00	0.00	0.00	0.00	1583.25	0.00
Total Revenue	141164212.29	171550783.37	7084759.11	672794.80	450221.25	458816.40
Expenses:						
Cost of Sales	129301526.15	175038417.78	10579194.81	83900.50	127631.00	123256.62
Changes in inventories of finished goods, WIP and Stock-in-Trade	(1526931.22)	(17984867.84)	(4244096.00)	0.00	0.00	0.00
Employee benefits expense	3073796.00	2180191.00	540912.00	354619.75	165000.00	120000.00
Finance costs	744835.06	192440.97	9273.75	275.75	0.00	1988.77
Depreciation and amortization expense	467433.55	510489.31	72263.80	4738.13	4738.13	2998.65
Preliminary Expenses written off	0.00	0.00	0.00	10000.00	10000.00	10000.00
Other expenses	4271305.83	2667938.61	640196.66	106664.38	16699.60	17026.45
Total Expenses	136331965.37	162604609.83	7597745.02	560198.51	324068.73	275270.49
Profit before exceptional and extraordinary items and tax (A-B)	4832246.92	8946173.54	(512985.91)	112596.30	126152.53	183545.91
Exceptional item	0.00	0.00	0.00		0.00	0.00
Profit before extraordinary items and tax	4832246.92	8946173.54	(512985.91)	112596.30	126152.53	183545.91
Extraordinary item	0.00	0.00	0.00	0.00	0.00	0.00
Profit Before Tax	4832246.92	8946173.54	(512985.91)	112596.30	126152.53	183545.91
Provision for Tax						
- Current Tax	1500000.00	2108010.00	0.00	32916.00	36515.00	53019.00
- Fringe Benefit Tax	0.00	0.00	0.00	0.00	0.00	0.00
- Tax adjustment of prior years	0.00	0.00	0.00	6545.00	0.00	0.00
- Deferred Tax Liability / (Asset)	252366.99	424215.75	74205.15	1876.33	2465.82	3696.83
Restated profit after tax from continuing operations	3079879.93	6413947.79	(587191.06)	71258.96	87171.71	126830.08
Discontinuing operation						
Restated profit for the year	3079879.93	6413947.79	(587191.06)	71258.96	87171.71	126830.08
Balance brought forward from previous year	6112017.47	(301930.32)	285260.75	214001.79	126830.08	0.00
Accumulated Profit/ (Loss) carried to Balance Sheet	9191897.40	6112017.47	(301930.32)	285260.75	214001.79	126830.08

Note: The above statement should be read with the significant accounting policies and notes to restated summary statements, restated statement of assets and liabilities and restated cash flow statement as appearing in Annexures IV, I and III.

ANNEXURE - III
RESTATED CASH FLOW STATEMENT

(Amt. in ₹)

Particulars	For 9 months period ended	For the Year ended				
	31-12-13	31-03-13	31-03-12	31-03-11	31-03-10	31-03-09
1. Cash Flow From Operating Activities:						
Net Profit after taxes	3079879.93	6413947.79	(587191.06)	71258.96	87171.71	126830.08
<i>Adjustments for:</i>						
Depreciation and amortization expense	467433.55	510489.31	72263.80	4738.13	4738.13	2998.65
Interest and Finance Cost	744835.06	192440.97	9273.75	275.75	0.00	1988.77
Current Income Tax	1500000.00	2108010.00	0.00	32916.00	36515.00	53019.00
Tax Adjustment of Previous year	0.00	0.00	0.00	6545.00	0.00	0.00
Deferred Tax	252366.99	424215.75	74205.15	1876.33	2465.82	3696.83
Preliminary Expenses	0.00	0.00	0.00	10000.00	10000.00	10000.00
Operating Profit before Working Capital Changes	6044515.53	9649103.82	(431448.36)	127610.17	140890.65	198533.33
<i>Adjustments for:</i>						
Changes in Inventories	(1526931.22)	(17984867.84)	(4244096.00)	0.00	0.00	0.00
Changes in Trade Receivables	16533134.00	(18835975.00)	(395828.10)	(84903.00)	13638.00	(277808.90)
Changes in other current assets	766786.88	(376920.48)	(995375.64)	(46937.17)	(24355.00)	(6634.00)
Changes in Trade Payables	(7492954.55)	17032771.50	5854433.15	(36569.00)	(55896.87)	195027.87
Changes in other Current Liabilities & Short-term Provisions	2564398.00	805766.00	56091.00	0.00	0.00	0.00
Cash Generated from Operation	16888948.64	(9710122.00)	(156223.95)	(40799.00)	74276.78	109118.30
Taxes Paid	2668510.00	1500000.00	231196.00	45644.00	52420.00	0.00
Net Cash from Operating Activities	14220438.64	(11210122.00)	(387419.95)	(86443.00)	21856.78	109118.30
2. Cash Flow From Investing Activities:						
Fixed Assets Purchased	(2167655.30)	(1495571.40)	(13770857.05)	0.00	0.00	(99750.00)
Interest Received	0.00	0.00	0.00	0.00	0.00	0.00
Long/Short Term Loans and Advance	(4464649.35)	183567.37	(380482.00)	0.00	0.00	0.00
Long Term Current Liabilities	0.00	0.00	0.00	0.00	0.00	0.00
Net Cash from Investing Activities	(6632304.65)	(1312004.03)	(14151339.05)	0.00	0.00	(99750.00)
3. Cash Flow From Financing Activities:						
Proceeds from issue of shares	0.00	9000000.00	900000.00	0.00	0.00	100000.00
Proceeds from Short term borrowings	2654818.85	3396113.00	0.00	0.00	(80000.00)	80000.00
Proceeds from Long term borrowings	(6097468.30)	214860.97	13500000.00	700000.00	0.00	0.00
Expenses towards	0.00	0.00	0.00	0.00	0.00	(30000.00)

Bansal Roofing Products Limited

incorporation of Company						
Interest paid	(744835.06)	(192440.97)	(9273.75)	(275.75)	0.00	(1988.77)
Net Cash from Financing Activities	(4187484.51)	12418533.00	14390726.25	699724.25	(80000.00)	148011.23
Net Increase/ (Decrease) in Cash & Cash Equivalents	3400649.48	(103593.03)	(148032.75)	613281.25	(58143.22)	157379.53
Cash & Cash Equivalents at the beginning of the year	460891.78	564484.81	712517.56	99236.31	157379.53	0.00
Cash & Cash Equivalents at the end of the year	3861541.26	460891.78	564484.81	712517.56	99236.31	157379.53

Note:

1. The Cash Flow Statement has been prepared under the 'Indirect Method' as set out in Accounting Standard - 3 on Cash Flow Statements as recommended by Companies accounting standard rules,2006.
2. Figures in Brackets represents outflow.
3. The above statement should be read with the significant accounting policies and notes to restated summary statements, restated statement of assets and liabilities and restated statement of profit and loss as appearing in Annexures IV, I and II.

Significant Accounting Policies and Notes to Restated Summary Statements

Nature of Operations

Bansal Roofing Products Limited was incorporated in the year 2008. The Company is very well known in their areas of expertise. The manufacturing facility of the Company has been started in financial year 2012-13.

Products of the Company include Colour Coated Roof Sheets, FRP Roof Sheets, Polycarbonate Sheets, Turbo Ventilators and other miscellaneous Roofing Accessories.

NOTE 1

SIGNIFICANT ACCOUNTING POLICIES:

Basis of preparation of financial statements

These financial statements are prepared under the historical cost basis of accounting and evaluated on a going concern basis, with revenues and expenses accounted for on their accrual to comply in all material aspects with the applicable accounting principles and applicable Accounting Standards notified U/s. 211(3C) of the Companies Act, 1956 and other relevant provisions of the Companies Act, 1956.

Use of estimates

The preparation of financial statements require estimates and assumptions to be made that affect the reported balances of assets as on the date of the financial statements and the reported amount of revenues and expenses during the reporting period. Accounting estimates could change from period to period. Actual results could differ from these estimates. Appropriate changes in estimates are made as and when the Management becomes aware of the changes in the circumstances surrounding the estimates. Changes in estimates are reflected in the financial statements in the period in which the changes are made and if material, their effects are disclosed in the notes to the financial statements.

The following significant accounting policies are adopted in the preparation and presentation of these financial statements:

Inventories (AS 2)

Stock of Raw Material and WIP is valued at cost. Finished goods are valued at cost or market value whichever is less. Cost of Raw Material and Finished Goods includes the purchase cost (Net of any taxes on which credits are received or receivable) and other incidental cost, to bring such material to its present location and condition. The Company follows First in First out (FIFO) method for valuation of inventory.

Cash Flows (AS 3)

Cash flows are reported using the indirect method, whereby profit after tax is adjusted for the effects of transactions of non-cash nature, any deferrals or accruals of past or future operating cash receipts or payments and item of income or expenses associated with investing or financing cash flows. Cash flows from operating, investing and financing activities of the Company are segregated, accordingly.

Depreciation (AS 6)

Depreciation is provided on Straight Line Method at the rates and in the manners prescribed in Schedules XIV to the Companies Act, 1956, on the basis of shifts / manners of utilization of the assets. Depreciation on additions during the year has been provided on pro-rata basis with reference to the number of days utilized.

Type of Asset	Rate Applied
Plant & Mach.	4.75%
Bore well	4.75%
Computer	16.21%
Factory Building	3.34%

Bansal Roofing Products Limited

Electric Fitting	4.75%
Furniture & Fixture	6.33%
Office Equipments	4.75%
Tools & Tackles	4.75%
Air Conditioner	4.75%
Compressor	4.75%
Inverter	4.75%
Maruti Car	9.50%
Water Cooler	4.75%
Finger Print Machine	4.75%

Revenue Recognition (AS 9)

Revenue is recognised when it is earned and no significant uncertainty exists as to its realisation or collection. Revenue from sale of goods is recognised on delivery of the products, when all significant contractual obligations have been satisfied, the property in goods is transferred for a price, significant risks and rewards of ownership are transferred to the customers and no effective ownership is retained. Sales are net off taxes and accounted on mercantile basis. Revenue from Labour/Job Work is recognised on the basis of completion of services being provided.

Fixed Assets (AS 10)

(i) Fixed assets shown under gross block are valued at cost of acquisition inclusive of inward freight, duties and taxes and incidental expenses related to acquisition and also include cost of installation wherever incurred. All pre-operative costs, including specific financing cost till commencement of commercial production, net charges on foreign exchange contracts and adjustment arising from foreign exchange rate variations attributable to the fixed assets are capitalised.

(ii) Depreciation on fixed assets has been charged on Straight Line Method, pro-rata for the period of use, by adopting the revised rates of depreciation specified in Schedule XIV of the Companies Act, 1956.

Foreign Currency Transactions (AS 11)

(i) The reporting currency of the company is Indian rupees.

(ii) Transactions in foreign currencies are recognized at the prevailing exchange rates on the transaction dates. Realize gain and losses on settlement of foreign currency transactions are recognized in the profit and loss account under the natural revenue heads of accounts. Exchange differences relating to fixed assets are capitalised to respective Fixed Asset.

Employee benefits (AS 15)

Defined-contribution plans:

(i) Provident fund and pension scheme are Defined Contribution Plans in the Company. The Company is a member of recognized Provident Fund scheme established under The Provident Fund & Miscellaneous Act, 1952 by the Government of India. The Company is contributing 12% of Basic Salary of eligible employees under the scheme every month. The contribution paid or payable under the scheme is recognized during the period under which the employee renders the related services.

Defined-Benefit plans:

(ii) Employee Gratuity Fund Scheme is the Defined Benefit Plan. Provision for gratuity has been made in the accounts, in case of those employees who are eligible for the retirement benefits. Gratuity is paid at the time of retirement of employees. Provision for gratuity liability is provided based on Actuarial Valuation made.

(iii) Short Term Employee Benefits like leave benefit, if any, are paid along with salary and wages on a month to month basis, bonus to employees are charged to profit and loss account on the basis of actual payment on year to year basis.

Related Party Transaction (AS 18)

Related party transactions are reported in line with the requirement of Accounting Standard 18.

Earnings per share (AS 20)

Basic and Diluted earnings/(loss) per share are calculated by dividing the net profit / (loss) for the period attributable to equity shareholders (after deducting preference dividends and attributable taxes, if any) by the weighted average number of equity shares outstanding during the period. The weighted average number of equity shares outstanding during the period are adjusted for any bonus shares issued and fresh Issue of equity shares during the year and also after the balance sheet date but before the date the financial statements are approved by the board of directors.

Taxes on income (AS 22)

Current tax -Provision for current tax/minimum alternate tax (MAT) is made based on tax liability computed after considering tax allowances and exemptions.

Deferred tax -Deferred tax is recognised on timing differences between the accounting income and the taxable income for the year and quantified using the tax rates and laws enacted or substantively enacted as on the Balance Sheet date. Deferred tax assets are recognised and carried forward to the extent that there is a reasonable or virtual certainty, as may be applicable, that sufficient future taxable income will be available against which such deferred tax asset can be realised.

Impairment of assets (AS 28)

An impairment loss is charged to the Statement of profit and loss in the year in which an asset is identified as impaired. The impairment loss recognised in prior accounting period is reversed if there has been a change in the estimate of recoverable amount

Provisions and contingent liabilities (AS 29)

A provision is recognised when the Company has a present obligation as a result of past events and it is probable that an outflow of resources will be required to settle the obligation, in respect of which a reliable estimate can be made. Provisions are not discounted to their present value and are determined based on best estimates required to settle the obligation at the balance sheet date.

A contingent liability is a possible obligation that arises from past events whose existence will be confirmed by the occurrence or non-occurrence of one or more uncertain future events beyond the control of the company or a present obligation that is not recognized because it is not probable that an outflow of resources will be required to settle the obligation. A contingent liability also arises in extremely rare cases where there is a liability that cannot be recognized because it cannot be measured reliably.

As on December 31, 2013, In the opinion of the Board there are no contingent liabilities for any of the years covered by this Statement, except During the process of restatement of financial statements by peer review auditor they have noticed violation of The Companies Act, 1956 and Accounting standards the effect for the same was given in restated financial statements.

The company is in process of making an application Under Section 621A of the Companies Act, 1956 to the Registrar of Companies compounding of various offence made by the company. The amount of Compounding various violations will be decided by the ROC/Company Law Board after application and due verification of each offence.

NOTE 2

NOTES TO RESTATED SUMMARY STATEMENTS:

The financial statements for the years ended March 31, 2011, 2010 & 2009 were prepared as per the then-applicable pre-revised Schedule VI of the Companies Act 1956. Consequent to the notification of the revised schedule VI under the Companies Act, 1956, the financial statements for the for period from April 1, 2013 to December 31, 2013 and year ended March 31, 2013 & 2012 are prepared as per the revised schedule VI. Accordingly, the figures of the previous years have also been re-classified to conform to classification as per the revised schedule VI. The adoption of revised schedule VI for the figures of the previous year does not impact recognition and measurement principles followed for the preparation of these financial statements.

Contingent liabilities and commitments (to the extent not provided for)

In the opinion of the Board there are no contingent liabilities for any of the years covered by this Statement, except During the process of restatement of financial statements by peer review auditor they have noticed violation of The Companies Act, 1956 and Accounting standards the effect for the same was given in restated financial statements.

The company is in process of making an application Under Section 621A of the Companies Act, 1956 to the Registrar of Companies compounding of various offence made by the company. The amount of Compounding various violations will be decided by the ROC/Company Law Board after application and due verification of each offence.

Disclosure under Micro, Small and Medium Enterprises Development Act, 2006

In the absence of information regarding outstanding dues of MICRO or Small Scale Industrial Enterprise(s) as per The Micro, Small & Medium Enterprise Development Act, the Company has not disclosed the same as required by Schedule VI to the Companies Act, 1956.

Foreign Currency Transactions (AS 11)

Particulars	For the period/year ended					
	31-12-13	31-03-13	31-03-12	31-03-11	31-03-10	31-03-09
FOB Value of Export	10,42,411.00	0.00	0.00	0.00	0.00	0.00
CIF Value of Import (Capital Goods)	0.00	0.00	24,17,338.00	0.00	0.00	0.00

Related Party Transactions

Related party transactions are already reported as per AS-18 of Companies (Accounting Standards) Rules, 2006, as amended, in the "Annexure N" of the enclosed financial statements."

Deferred Tax liability/Asset

Deferred Tax liability/Asset in view of Accounting Standard – 22: "Accounting for Taxes on Income" as at the end of the year is as under:

Calculation of Deferred Tax liability/Assets of previous year and preceding years:

Particulars	For 9 months period ended	For the year ended				
	31-12-13	31-03-13	31-03-12	31-03-11	31-03-10	31-03-09
Opening Balance (A)						
Opening Balance of Deferred Tax (Asset) / Liability	506,459.89	82,244.14	8,038.98	6,162.65	3,696.83	0.00
Current Year Provision (B)						
(DTA) / DTL on Depreciation	259,847.57	304,947.93	203,399.60	1,876.33	2,465.82	3,696.83
(DTA) / DTL on Carry Forward Loss	0.00	129,194.45	(129,194.45)	0.00	0.00	0.00
(DTA) / DTL on Provision for Gratuity	(7,480.58)	(9,926.63)	0.00	0.00	0.00	0.00
Closing Balance of Deferred Tax (Asset) / Liability (A+B)	758,826.88	506,459.89	82,244.14	8,038.98	6,162.65	3,696.83

Note: The above statement should be read with the significant accounting policies and notes to restated summary statement of profit and loss account and cash flows statement as appearing in Annexures II, III and IV.

Auditors' Remuneration:

Particulars	For the period/year ended					
	31-12-13	31-03-13	31-03-12	31-03-11	31-03-10	31-03-09
Statutory Audit Fees	0.00	35000.00	15000.00	7500.00	5000.00	5000.00
Tax Audit Fees & Taxation Matters	-	10000.00	10000.00	5000.00	5000.00	5000.00
Other Fees	10000.00	0.00	0.00	0.00	0.00	0.00
Total	10000.00	45000.00	25000.00	12500.00	10000.00	10000.00

Bansal Roofing Products Limited
Earnings per Share:

Earnings per Share have been calculated as under:

Particulars	For the period/year ended					
	31-12-13	31-03-13	31-03-12	31-03-11	31-03-10	31-03-09
A. Number of Shares at the beginning of the year	1000000.00	100000.00	10000.00	10000.00	10000.00	0.00
Shares issued during the year:						
- Allotment	0.00	900000.00	90000.00	0.00	0.00	10000.00
B. Total Number of equity shares outstanding at the end of the year	1000000.00	1000000.00	100000.00	10000.00	10000.00	10000.00
C. Weighted average number of equity shares outstanding during the year	1000000.00	176438.36	56849.32	10000.00	10000.00	9178.08
D. Net profit after tax available for equity shareholders as restated	3079879.93	6413947.79	(587191.06)	71258.96	87171.71	126830.08
E. Basic and Diluted earnings per share (₹)	3.08	36.35	(10.33)	7.13	8.72	13.82

Note. The Basic and diluted EPS for the period ended December 31, 2013 after considering Bonus issue of 5,17,200 equity shares made on January 23, 2014 is ₹ 2.03 per share.

Employee benefits:
(a) Defined Benefit Plan

The Company has adopted the Accounting Standard 15 (revised 2005) on Employee Benefits as per an actuarial valuation carried out by an independent actuary. The disclosures as envisaged under the standard are as under:

Particulars	For the period/year ended					
	31-12-13	31-03-13	31-03-12	31-03-11	31-03-10	31-03-09
1. The amounts recognised in the Balance Sheet are as follows:						
Present value of unfunded obligations recognised	56,334	32,125	0.00	0.00	0.00	0.00
Un-Funded Status	56,334	32,125	0.00	0.00	0.00	0.00
Net Liability	56,334	32,125	0.00	0.00	0.00	0.00
2. The amounts recognised in the Profit & Loss A/c are as follows:						
Current Service Cost	28,854	32,125	0.00	0.00	0.00	0.00
Interest on Defined Benefit Obligation	1,932	-	0.00	0.00	0.00	0.00
Net Actuarial Losses / (Gains) Recognized in Year	(6,577)	-	0.00	0.00	0.00	0.00
Expense recognized in P&L	24,209	32,125	0.00	0.00	0.00	0.00
3. Changes in the present value of defined benefit obligation:						
Defined benefit obligation as at the beginning of the year/period	32,125	0.00	0.00	0.00	0.00	0.00
Service cost	28,854	32,125	0.00	0.00	0.00	0.00
Interest cost	1,932	0.00	0.00	0.00	0.00	0.00
Actuarial Losses/(Gains)	(6,577)	0.00	0.00	0.00	0.00	0.00
Defined benefit obligation as at the end of the year/period	56,334	32,125	0.00	0.00	0.00	0.00
Benefit Type :						
Retirement Age:	58 Years	58 Years	0.00	0.00	0.00	0.00
Vesting Period:	5 Years	5 Years	0.00	0.00	0.00	0.00

Bansal Roofing Products Limited

The principal actuarial assumptions for the above are:						
Discount rate per annum	9.41%	8.02%	0.00	0.00	0.00	0.00
Expected salary escalation rate per annum	7.00%	7.00%	0.00	0.00	0.00	0.00
Attrition Rate per Annum	2.00%	2.00%	0.00	0.00	0.00	0.00

(b) Defined Contribution Plans

The Company is registered with the Regional Provident Fund Commissioner for the Employees' Provident Fund Scheme. Contributions to Provident Fund are included under head Salaries, allowances and welfare in the Statement of profit and loss.

Particulars	For the period/year ended					
	31-12-13	31-03-13	31-03-12	31-03-11	31-03-10	31-03-09
Provident Fund	32532.00	0.00	0.00	0.00	0.00	0.00

Realisations

In the opinion of the Board and to the best of its knowledge and belief, the value on realisation of current assets and loans and advances are approximately of the same value as stated.

Contractual liabilities

All other contractual liabilities connected with business operations of the Company have been appropriately provided.

Amounts in the financial statements

Amounts in the financial statements are rounded off to nearest rupees. Figures in brackets indicate negative values.

Previous year's figures

The Revised Schedule VI has become effective from 1 April, 2011 for the preparation of financial statements. This has significantly impacted the disclosure and presentation made in the financial statements. Figures of all the previous years dealt in this statement have been regrouped / reclassified wherever necessary to correspond with the current year's classification / disclosure to the extent possible.

Segment Reporting (AS 17)

The Company is predominantly in the business of Manufacturing of roofing sheets and as such there are no separate reportable segments.

Leases (AS 19)

(a) Finance lease

The Company has not entered into finance lease arrangements.

- (b) Operating leases are mainly in the nature of lease of office premises with no restrictions and are renewable by mutual consent. There are no restrictions imposed by lease arrangements. Lease rental payments made by the Company are recognized in the statement profit and loss account in restated financials under the head 'Other Expenses'.

Particulars	For the period/year ended					
	31-12-13	31-03-13	31-03-12	31-03-11	31-03-10	31-03-09
Office Rent	1,35,000.00	0.00	0.00	0.00	0.00	0.00

MATERIAL ADJUSTMENTS:

Appropriate adjustments have been made in the standalone restated financial statements, whenever required, by reclassification of the corresponding items of assets, liabilities and cash flow statement, in order to ensure consistency and compliance with requirement of Schedule VI and Accounting Standards.

Statement of Adjustments in the financial statements:

Particulars	For the period/year ended					
	31-12-13	31-03-13	31-03-12	31-03-11	31-03-10	31-03-09
Net Profits after tax and extraordinary items as per audited accounts but before Adjustments: (A)	3276242.89	6362329.02	(792227.26)	94586.64	118315.20	181689.91
Adjustment on Account of :						
Add:						
-Excess Provision of Income Tax	0.00	65946.00	0.00	0.00	0.00	0.00
-Excess Provision of Deferred Tax	0.00	0.00	152582.85	0.00	2812.18	0.00
-Provision for Changes in accounting Policy and estimates for Depreciation	0.00	152258.52	52453.35	2932.66	2559.33	1856.00
-Tax Adjustment of Earlier years	0.00	0.00	0.00	0.00	0.00	0.00
- Provision for Gratuity for earlier year	32125.00	0.00	0.00	0.00	0.00	0.00
Total Additions	32125.00	218204.52	205036.20	2932.66	5371.51	1856.00
Less:						
-Short Provision of Income Tax	16428.11	0.00	0.00	18906.00	36515.00	53019.00
-Short Provision of Deferred Tax	0.00	134460.75	0.00	809.33	0.00	3696.83
- Provision for Changes in accounting Policy and estimates for Depreciation	212059.85	0.00	0.00	0.00	0.00	0.00
-Tax Adjustment of Earlier years	0.00	0.00	0.00	6545.00	0.00	0.00
- Provision for Gratuity	0.00	32125.00	0.00	0.00	0.00	0.00
Total Deductions	228487.96	166585.75	0.00	26260.33	36515.00	56715.83
Net Profit as Restated	3079879.93	6413947.79	(587191.06)	71258.96	87171.71	126830.08

Provision for income tax for earlier years

The Company has not made any provisions for the Income tax in its financial statements for the year ended March 31, 2009, 2010 & 2011. The appropriate provisions are made in the restated financial statements and adjusted accordingly. However the Company has discharged its Income Tax Liabilities in regular course except there has been outstanding demand of ₹ 6660.00 for A.Y. 2010-11 and ₹ 10.00 for A.Y. 2009-10.

Tax Adjustment of Earlier years

Difference of on account of tax adjustments of prior years of ₹ 6545.00 consists of Interest on late payment of Income Tax have been duly accounted for to arrive at restated financial statements.

Provision for change in accounting policy and estimates for Depreciation

1. The Company has followed Written down Value method for depreciating its assets in financial year ended on March 31, 2009 and 2010. The Company changed its method of Depreciation from Written Down Value Method to Straight Line Method from the April 01, 2010. The retrospective effect of the same has been provided to arrive at the Restated Financial Statements.
2. The Company has not taken appropriate rates of Depreciation as per Schedule XIV of the Companies Act to provide the depreciation till March 31, 2013. Depreciation on fixed assets at appropriate rates as per Schedule XIV of the Companies Act has been taken to arrive at the Restated Financial Statements.

3. In the year ended March 31, 2012 classification of expenses of ₹ 143562.35 incurred towards structures designing for factory building was wrongly classified under Plant and Machinery. The same has been adjusted by correcting the same to arrive at the Restated Financial Statements.

The Company has provided for the above changes in its books of account on April 1, 2013. Statutory Auditor of the Company in their Audit Report for the Period April 1, 2013 to December 31, 2013 has accounted for the same.

Provision for Deferred Tax

Changes in Deferred Tax on account of change in accounting policy and estimates for Depreciation, has been provided for in the restated financial statements.

The Company has provided for the above changes in its books of account on April 1, 2013. Statutory Auditor of the Company in their Audit Report for the Period April 1, 2013 to December 31, 2013 has accounted for the same.

Provision for Gratuity

The Company has not provided for gratuity in F.Y. 2012- 13. However necessary provision for the same has been made to arrive at the Restated Financial Statements. Provision for gratuity liability is provided based on Actuarial Valuation made.

Statutory Auditor of the Company in their Audit Report for the Period April 1, 2013 to December 31, 2013 has accounted for non-provisioning of gratuity expenses of F.Y. 2012-13.

ANNEXURE - A

STATEMENT OF FIXED ASSETS

(Amt. in ₹)

PARTICULARS	As at					
	31-12-13	31-03-13	31-03-12	31-03-11	31-03-10	31-03-09
Tangible Assets						
Land	1925130.00	1925130.00	1925130.00	0.00	0.00	0.00
Plant & Mach.	6668067.91	5113538.97	4440997.67	87275.10	92013.23	96751.35
Borwell	33817.80	35156.26	36932.76	0.00	0.00	0.00
Computer	182521.57	62031.65	69179.83	0.00	0.00	0.00
Factory Building	6483599.02	6657903.91	6889254.03	0.00	0.00	0.00
Electric Fitting	224722.32	199373.38	209440.61	0.00	0.00	0.00
Furniture & Fixture	376335.56	246010.53	180513.00	0.00	0.00	0.00
Office Equipments	12907.16	13412.91	14084.18	0.00	0.00	0.00
Tools & Tackles	48525.56	19365.95	20336.28	0.00	0.00	0.00
AC	60900.57	35776.97	0.00	0.00	0.00	0.00
Compressor	14704.66	15252.21	0.00	0.00	0.00	0.00
Inverter	28352.13	29407.86	0.00	0.00	0.00	0.00
Maruti Car	372636.66	401748.00	0.00	0.00	0.00	0.00
Water Cooler	30315.65	16841.83	0.00	0.00	0.00	0.00
Finger Print Machine	8635.61	0.00	0.00	0.00	0.00	0.00
Total Tangible Assets	16471172.19	14770950.44	13785868.35	87275.10	92013.23	96751.35
Intangible Assets	0.00	0.00	0.00	0.00	0.00	0.00
Capital Work-in-Progress	0.00	0.00	0.00	0.00	0.00	0.00
Intangible assets under development	0.00	0.00	0.00	0.00	0.00	0.00
Grand Total	16471172.19	14770950.44	13785868.35	87275.10	92013.23	96751.35

ANNEXURE - B

STATEMENT OF NON-CURRENT INVESTMENTS

(Amt. in ₹)

Particulars	Uts	As at	Uts	As at	Uts	As at	Uts	As at	Uts	As at	Uts	As at
	Nos	31-12-13	Nos	31-03-13	Nos	31-03-12	Nos	31-03-11	Nos	31-03-10	Nos	31-03-09
<i>(Other Than Trade, at Cost)</i>												
<i>Investment in equity, Unquoted</i>		0.00		0.00		0.00		0.00		0.00		0.00
<i>(Traded, at Cost)</i>												
<i>Investment in equity, quoted</i>		0.00		0.00		0.00		0.00		0.00		0.00
Total		0.00		0.00		0.00		0.00		0.00		0.00

ANNEXURE - C

STATEMENT OF LONG-TERM LOANS AND ADVANCES

(Amt. in ₹)

PARTICULARS	As at					
	31-12-13	31-03-13	31-03-12	31-03-11	31-03-10	31-03-09
Unsecured, Considered Good unless otherwise stated						
Security Deposit MGVCL	41,544.00	41,544.00	41,544.00	0.00	0.00	0.00
Prepaid Expenses	2,400.00	0.00	0.00	0.00	0.00	0.00
Total	43,944.00	41,544.00	41,544.00	0.00	0.00	0.00

Note: None of the long term loans and advances as stated above are recoverable from Directors/ Promoters/ Promoter group /Associates/ Relatives of Directors/Subsidiary Company/ Group Company.

ANNEXURE - D

STATEMENT OF TRADE RECEIVABLES

(Amt. in ₹)

PARTICULARS	As At					
	31-12-13	31-03-13	31-03-12	31-03-11	31-03-10	31-03-09
Outstanding for a period exceeding six months (Unsecured and considered Good)						
From Directors/ Promoters/ Promoter group /Associates/ Relatives of Directors	0.00	0.00	0.00	0.00	0.00	0.00
Others	0.00	1017.00	0.00	0.00	0.00	0.00
Outstanding for a period not exceeding 6 months (Unsecured and considered Good)						
From Directors/ Promoters/ Promoter group /Associates/ Relatives of Directors	0.00	9,293,039.00	744902.00	0.00	0.00	0.00
Others	3,047,743.00	10,286,821.00	0.00	349073.90	264170.90	277808.90
Total	3047743.00	19580877.00	744902.00	349073.90	264170.90	277808.90

ANNEXURE - E

STATEMENT OF CASH & CASH EQUIVALENTS

(Amt. In ₹)

PARTICULARS	As at					
	31-12-13	31-03-13	31-03-12	31-03-11	31-03-10	31-03-09
Cash on Hand	998,895.59	138,309.00	18,079.00	52,517.00	15,000.00	15,200.00
Balances with Banks						
- In Current Accounts	2,862,645.67	322,582.78	546,405.81	660,000.56	84,236.31	142,179.53
- In Bank Deposits	0.00	0.00	0.00	0.00	0.00	0.00
Total	3,861,541.26	460,891.78	564,484.81	712,517.56	99,236.31	157,379.53

ANNEXURE - F

STATEMENT OF SHORT-TERM LOANS AND ADVANCES

(Amt. In ₹)

PARTICULARS	As at					
	31-12-13	31-03-13	31-03-12	31-03-11	31-03-10	31-03-09
Unsecured, Considered Good unless otherwise stated						
Prepaid Expenses	1,600.00	0.00	0.00	0.00	0.00	0.00
Prepaid Insurance	66,462.00	0.00	0.00	0.00	0.00	0.00
Advance to Suppliers	4,533,738.98	129,370.63	338,938.00			
Advance to Employees	15,819.00	26,000.00	0.00	0.00	0.00	0.00
Total	4,617,619.98	155,370.63	338,938.00	0.00	0.00	0.00

ANNEXURE - G

STATEMENT OF OTHER CURRENT ASSETS

(Amt. In ₹)

PARTICULARS	As at					
	31-12-13	31-03-13	31-03-12	31-03-11	31-03-10	31-03-09
Balance with Government Authorities	5088725.41	3187002.29	1310081.81	116426.17	83409.00	6634.00
Preliminary Expenses	0.00	0.00	0.00	0.00	10000.00	20000.00
Total	5088725.41	3187002.29	1310081.81	116426.17	93409.00	26634.00

ANNEXURE - H

STATEMENT OF SHARE CAPITAL, RESERVES AND SURPLUS

(Amt. in ₹)

Particulars	As at					
	31-12-13	31-03-13	31-03-12	31-03-11	31-03-10	31-03-09
Share Capital						
Authorised Share Capital						
Equity shares of ₹10 each	1000000.00	1000000.00	100000.00	10000.00	10000.00	10000.00
Share Capital	1000000.00	1000000.00	100000.00	10000.00	10000.00	10000.00
Issued, Subscribed and Paid up Share Capital						
Equity Shares of ₹ 10 each fully paid up	1000000.00	1000000.00	100000.00	10000.00	10000.00	10000.00
Share Capital (in ₹)	1000000.00	1000000.00	100000.00	10000.00	10000.00	10000.00
Total	1000000.00	1000000.00	100000.00	10000.00	10000.00	10000.00
Reserves and Surplus						
Share Premium	0.00	0.00	0.00	0.00	0.00	0.00
General Reserve	0.00	0.00	0.00	0.00	0.00	0.00
Surplus in Profit and Loss account	9191897.40	6112017.47	(301930.32)	285260.75	214001.79	126830.08
Total	9191897.40	6112017.47	(301930.32)	285260.75	214001.79	126830.08

ANNEXURE - I

STATEMENT OF LONG TERM AND SHORT TERM BORROWINGS

(Amt. In ₹)

PARTICULARS	As at					
	31-12-13	31-03-13	31-03-12	31-03-11	31-03-10	31-03-09
Long Term Borrowings						
<i>From Banks (Secured)</i>						
Car Loan - HDFC Bank	117392.67	214860.97	0.00	0.00	0.00	0.00
<i>Loans and advances from related parties (Unsecured)</i>						
<i>From Promoters (Unsecured)</i>						
Kaushalkumar S. Gupta	8200000.00	14200000.00	14200000.00	700000.00	0.00	0.00
Total	8317392.67	14414860.97	14200000.00	700000.00	0.00	0.00

Current portion of long-term borrowings, included under Other current liabilities						
Car Loan - HDFC Bank	122175.00	94724.00	0.00	0.00	0.00	0.00

Short Term Borrowings						
<i>From Banks (Secured)</i>						
Cash Credit - State Bank of India	5550931.85	3396113.00	0.00	0.00	0.00	0.00
<i>Loans and advances from related parties (Unsecured)</i>						
<i>From Promoters</i>						
Sangeeta K. Gupta	0.00	0.00	0.00	0.00	0.00	80000.00
<i>From Other related Parties</i>						
Satishkumar K. Agarwal	500000.00	0.00	0.00	0.00	0.00	0.00
Total	6050931.85	3396113.00	0.00	0.00	0.00	80000.00
The above amount includes:						
Secured Borrowings	5790499.52	3705697.97	0.00	0.00	0.00	0.00
Unsecured Borrowings	8700000.00	14200000.00	14200000.00	700000.00	0.00	0.00

Notes:

- 1) The terms and conditions and other information in respect of Secured Loans are given in Annexure -I (A)
- 2) The terms and conditions and other information in respect of Unsecured Loans are given in Annexure - I (B)

ANNEXURE - I (A)

STATEMENT OF PRINCIPAL TERMS OF SECURED LOANS AND ASSETS CHARGED AS SECURITY

Name of Lender	Type of Loan Facility	Amount Sanctioned	Amount Outstanding as at 31.12.13	Amount Outstanding as at 31.03.2013	Rate of Interest (%)	Repayment Schedule	Securities Offered
State Bank of India	Cash Credit	20000000.00	5550931.85	3396113.00	Base Rate (Currently 10%) +3.75%	On Demand	See Note 1 Below
HDFC Bank (A/c No. 23571589)	Maruti Ecco	317000.00	239567.67	309584.97	11.50%	36 Equal Monthly Installments starting from 05.03.13. See Note 2 Below	Hypothecation of Vehicle

Note 1

Prime Security Hypothecation of entire Stocks and Book Debts

Collateral Securities **Immovable Security**

Equitable Mortgage over Shop No. 1-9, Behind Shivam Hotel, Dabhoi Road, Kapurai Crossing, Vadodara of area measuring 11464 Sq. Feet

Personal Guarantees

Mr. Kaushalkumar S. Gupta

Mr. Satishkumar S.

Gupta

Mrs. Sangeeta K. Gupta

Mr. Ashish S. Gupta

Note 2

VEHICLE LOAN

a) Repayment Schedule :

Year	Yearly Installment (Principal Component)	Total Amount Outstanding
2012-13	7415.03	309584.97
2013-14	94724.70	214860.27
2014-15	106215.13	108645.14
2015-16	108645.14	0.00
TOTAL	317000.00	

b) Purpose: Business

ANNEXURE - I (B)
STATEMENT OF TERMS & CONDITIONS OF UNSECURED LOANS

Details of Unsecured Loans outstanding as at the end of the respective periods from Directors/Promoters/Promoter Group /Associates/Relatives of Directors/Subsidiary/Group Companies

Unsecured Loans from Promoters/Directors are interest free that are taken without any preconditions attached towards repayments.

Kaushalkumar S. Gupta						
Rate of Interest- Nil						
Particulars	As at					
	31-12-13	31-03-13	31-03-12	31-03-11	31-03-10	31-03-09
Opening Balance	14200000.00	14200000.00	700000.00	0.00	0.00	0.00
Amount Received/credited	0.00	0.00	13500000.00	700000.00	0.00	0.00
Amount repaid/adjusted	6000000.00	0.00	0.00	0.00	0.00	0.00
Outstanding Amount	8200000.00	14200000.00	14200000.00	700000.00	0.00	0.00

Sangeeta K. Gupta						
Rate of Interest- Nil						
Particulars	As at					
	31-12-13	31-03-13	31-03-12	31-03-11	31-03-10	31-03-09
Opening Balance	0.00	0.00	0.00	0.00	80000.00	0.00
Amount Received/credited	0.00	0.00	0.00	0.00	0.00	80000.00
Amount repaid/adjusted	0.00	0.00	0.00	0.00	80000.00	0.00
Outstanding Amount	0.00	0.00	0.00	0.00	0.00	80000.00

Satishkumar K. Agarwal						
Rate of Interest- 12%						
Particulars	As at					
	31-12-13	31-03-13	31-03-12	31-03-11	31-03-10	31-03-09
Opening Balance	0.00	0.00	0.00	0.00	80000.00	0.00
Amount Received/credited	500000.00	0.00	0.00	0.00	0.00	80000.00
Amount repaid/adjusted	0.00	0.00	0.00	0.00	80000.00	0.00
Outstanding Amount	500000.00	0.00	0.00	0.00	0.00	80000.00

ANNEXURE - J

STATEMENT OF DEFERRED TAX (ASSETS) / LIABILITIES

(Amt. in ₹)

Particulars	For the 9 months period ended	For the year ended				
	31-12-13	31-03-13	31-03-12	31-03-11	31-03-10	31-03-09
Opening Balance (A)						
Opening Balance of Deferred Tax (Asset) / Liability	506,459.89	82,244.14	8,038.98	6,162.65	3,696.83	0.00
Current Year Provision (B)						
(DTA) / DTL on Depreciation	259,847.57	304,947.93	203,399.60	1,876.33	2,465.82	3,696.83
(DTA) / DTL on Carry Forward Loss	0.00	129,194.45	(129,194.45)	0.00	0.00	0.00
(DTA) / DTL on Provision for Gratuity	(7,480.58)	(9,926.63)	0.00	0.00	0.00	0.00
Closing Balance of Deferred Tax (Asset) / Liability (A+B)	758,826.88	506,459.89	82,244.14	8,038.98	6,162.65	3,696.83

ANNEXURE - K

STATEMENT OF TRADE PAYABLES

(Amt. in ₹)

PARTICULARS	As at					
	31-12-13	31-03-13	31-03-12	31-03-11	31-03-10	31-03-09
Trade Payables						
For Goods & Services	14627025.10	21649660.10	4868944.10	0.00	126131.00	62027.87
For Capital Goods	227357.00	59950.35	971589.05			
For Expenses	642430.00	1280156.20	116462.00	102562.00	13000.00	133000.00
Total	15496812.10	22989766.65	5956995.15	102562.00	139131.00	195027.87

ANNEXURE - L

STATEMENT OF OTHER CURRENT LIABILITIES AND SHORT TERM PROVISIONS

(Amt. in ₹)

PARTICULARS	As at					
	31-12-13	31-03-13	31-03-12	31-03-11	31-03-10	31-03-09
Other Current Liabilities						
Current maturities of long-term borrowings						
- Vehicle Loan	122175.00	94724.00	0.00	0.00	0.00	0.00
Statutory Dues	2207052.00	514418.00	54729.00	36515.00	53019.00	0.00
Advance from customers	3168119.00	90773.00	0.00	0.00	0.00	0.00
Other Liabilities	17100.00	0.00	0.00	0.00	0.00	0.00
Total	5514446.00	699915.00	54729.00	36515.00	53019.00	0.00
Short-Term Provisions						
Provision for Income Tax	1500000.00	2108010.00	0.00	32916.00	36515.00	53019.00
Provision for Bonus	0.00	166332.00	37877.00	0.00	0.00	0.00
Provision for Gratuity	56334.00	32125.00	0.00	0.00	0.00	0.00
Total	1556334.00	2306467.00	37877.00	32916.00	36515.00	53019.00

ANNEXURE - M

STATEMENT OF OTHER INCOME

(Amt. In ₹)

Particulars	For 9 months period ended	For the year ended				
	31-12-13	31-03-13	31-03-12	31-03-11	31-03-10	31-03-09
Recurring Income:						
Bank Charges Reversed	0.00	0.00	0.00	0.00	1583.25	0.00
Interest Income	6562.00	0.00	0.00	0.00	0.00	0.00
Total	6562.00	0.00	0.00	0.00	1583.25	0.00

ANNEXURE - N

STATEMENT OF RELATED PARTY TRANSACTION

Amt. in ₹

Names of the related parties with whom transactions were carried out during the years and description of relationship:	
Kaushalkumar S. Gupta	Directors/Key Management Personnel
Sangeeta K. Gupta	
Satishkumar S. Gupta	
Ashishkumar S. Gupta	Relatives of Directors/Key Management Personnel
Satishkumar K. Agarwal	
Agrawal Associates	Entities significantly influenced by Directors/Key Management Personnel or/and Relatives of Directors/Key Management Personnel
Bansal Roofing Products	
Ashinishi Mktg. & Engg. Co.	
Satishkumar S. Gupta HUF	

1. Transactions with Directors/Key Management Personnel

Nature of Transactions	For 9 months period ended	For the year ended				
	31-12-13	31-03-13	31-03-12	31-03-11	31-03-10	31-03-09
Remuneration						
Kaushalkumar S. Gupta	695000.00	540000.00	0.00	0.00	0.00	0.00
Sangeeta K. Gupta	80000.00	180000.00	120000.00	120000.00	120000.00	120000.00
Salary						
Sangeeta K. Gupta	100000.00	0.00	0.00	0.00	0.00	0.00
Rent						
Sangeeta K. Gupta	135000.00	0.00	0.00	0.00	0.00	0.00
Equity Contributions*						
Kaushalkumar S. Gupta	0.00	8800000.00	540000.00	0.00	0.00	60000.00
Sangeeta K. Gupta	0.00	0.00	260000.00	0.00	0.00	20000.00
Satishkumar S. Gupta	0.00	0.00	100000.00	0.00	0.00	20000.00
* There was no share application money pending at the end of reporting periods.						
Finance						
Kaushalkumar S. Gupta						
Opening Balance	14200000.00	14200000.00	700000.00	0.00	0.00	0.00

Bansal Roofing Products Limited

Amount Debited during the period/year	6000000.00	0.00	0.00	0.00	0.00	0.00
Amount Credited during the period/year	0.00	0.00	13500000.00	700000.00	0.00	0.00
Closing Balance	8200000.00	14200000.00	14200000.00	700000.00	0.00	0.00
Sangeeta K. Gupta						
Opening Balance	0.00	0.00	0.00	0.00	80000.00	0.00
Amount Debited during the period/year	0.00	0.00	0.00	0.00	80000.00	0.00
Amount Credited during the period/year	0.00	0.00	0.00	0.00	0.00	80000.00
Closing Balance	0.00	0.00	0.00	0.00	0.00	80000.00

2. Transactions with Relatives of Directors/Key Management Personnel

Nature of Transactions	For 9 months period ended	For the year ended				
	31-12-13	31-03-13	31-03-12	31-03-11	31-03-10	31-03-09
Remuneration						
Ashishkumar S. Gupta	450000.00	0.00	0.00	0.00	0.00	0.00
Equity Contributions						
Ashishkumar S. Gupta	0.00	200000.00	0.00	0.00	0.00	0.00
Purchase of Fixed Asset						
Ashishkumar S. Gupta	0.00	5000.00	0.00	0.00	0.00	0.00
Finance						
Satishkumar K. Agarwal						
Opening Balance	0.00	0.00	0.00	0.00	0.00	0.00
Amount Debited during the period/year	0.00	0.00	0.00	0.00	0.00	0.00
Amount Credited during the period/year	500000.00	0.00	0.00	0.00	0.00	0.00
Closing Balance	500000.00	0.00	0.00	0.00	0.00	0.00

3. Transactions with Entities significantly influenced by Directors/Key Management Personnel or/and Relatives of Directors/Key Management Personnel

Nature of Transactions	For 9 months period ended	For the year ended				
	31-12-13	31-03-13	31-03-12	31-03-11	31-03-10	31-03-09
Agrawal Associates						
Opening Balance	9258966.85	736102.00	0.00	(126131.00)	(62027.87)	0.00
Amount Debited for Sales made	35668388.00	138999313.00	4102211.00	0.00	0.00	0.00
Amount Debited for Services rendered	58361.00	0.00	0.00	0.00	0.00	58550.00
Amount Debited for Payment received on our behalf	819962.00	2950293.00	0.00	0.00	0.00	0.00
Amount Debited for Bank Payment	188572.15	45646.00	2525248.00	377212.00	62027.87	67862.75

Bansal Roofing Products Limited

Amount Debited for Advances made for Purchases	3500000.00	0.00	0.00	0.00	0.00	0.00
Amount Credited for Purchases	37773.00	109593.00	1854487.00	84708.00	0.00	0.00
Amount Credited for Services received	121148.00	122956.00	0.00	0.00	126131.00	123256.62
Amount Credited for Payment made on our behalf	756510.00	1639838.15	0.00	166373.00	0.00	15184.00
Amount Credited for Bank Receipts	45097169.00	131600000.00	3357309.00	0.00	0.00	50000.00
Amount Credited for Purchase of Fixed Assets	31500.00	0.00	679561.00	0.00	0.00	0.00
<i>Closing Balance</i>	3450150.00	9258966.85	736102.00	0.00	(126131.00)	(62027.87)
Bansal Roofing Products						
<i>Opening Balance</i>	0.00	0.00	0.00	0.00	0.00	0.00
Amount Debited for Payment received on our behalf	0.00	0.00	0.00	0.00	122457.00	0.00
Amount Credited for Bank Receipts	0.00	0.00	0.00	0.00	122457.00	0.00
<i>Closing Balance</i>	0.00	0.00	0.00	0.00	0.00	0.00
Ashinishi Mktg. & Engg. Co.						
<i>Opening Balance</i>	0.00	0.00	0.00	0.00	0.00	0.00
Amount Debited for Sales made	396630.00	0.00	0.00	0.00	0.00	0.00
Amount Debited for Bank Payment	15162.00	0.00	0.00	0.00	0.00	2542.95
Amount Credited for Purchases	5439.00	0.00	0.00	0.00	0.00	0.00
Amount Credited for Services received	1008.00	0.00	0.00	0.00	0.00	2542.95
Amount Credited for Bank Receipts	396630.00	0.00	0.00	0.00	0.00	0.00
Amount Credited for Purchase of Fixed Assets	8715.00	0.00	0.00	0.00	0.00	0.00
<i>Closing Balance</i>	0.00	0.00	0.00	0.00	0.00	0.00
Satishkumar S. Gupta HUF						
<i>Opening Balance</i>	0.00	0.00	0.00	0.00	0.00	0.00
Amount Debited for Sales made	52070.00	0.00	0.00	0.00	0.00	0.00
Amount Credited for Bank Receipts	52070.00	0.00	0.00	0.00	0.00	0.00
<i>Closing Balance</i>	0.00	0.00	0.00	0.00	0.00	0.00
Sale of Goods						
Agrawal Associates	35668388.00	138999313.00	4102211.00	0.00	0.00	0.00
Ashinishi Mktg. & Engg. Co.	396630.00	0.00	0.00	0.00	0.00	0.00
Satishkumar S. Gupta HUF	52070.00	0.00	0.00	0.00	0.00	0.00

Bansal Roofing Products Limited

Purchase of Goods						
Agrawal Associates	37773.00	109593.00	1854487.00	84708.00	0.00	0.00
Ashinishi Mktg. & Engg. Co.	5439.00	0.00	0.00	0.00	0.00	0.00
Services Received						
Agrawal Associates	121148.00	122956.00	0.00	0.00	126131.00	123256.62
Ashinishi Mktg. & Engg. Co.	1008.00	0.00	0.00	0.00	0.00	2542.95
Services Rendered						
Agrawal Associates	55935.00	0.00	0.00	0.00	0.00	58550.00
Purchase of Fixed Assets						
Ashinishi Mktg. & Engg. Co.	8715.00	0.00	0.00	0.00	0.00	0.00
Agrawal Associates	31500.00	0.00	679561.00	0.00	0.00	0.00
**Purchase of Dies	*		**			
**Material for Factory Building						

ANNEXURE - O

STATEMENT OF CAPITALISATION

(Amt. in ₹)

Particulars	Pre-Issue		Post-Issue*
	31-12-13	31-03-13	
Debt			
Short Term Debt	6050931.85	3396113.00	6050931.85
Long Term Debt	8439567.67	14509584.97	8439567.67
Total Debt	14490499.52	17905697.97	14490499.52
Shareholders' Fund (Equity)			
Share Capital	10000000.00	10000000.00	21972000.00
Reserves & Surplus	9191897.40	6112017.47	17619897.40
Less: Miscellaneous Expenses not w/off	0.00	0.00	0.00
Total Shareholders' Fund (Equity)	19191897.40	16112017.47	39591897.40
Long Term Debt/Equity	0.44	0.90	0.21
Total Debt/Equity	0.76	1.11	0.37

Notes:

- Short term Debts represent which are expected to be paid/payable within 12 months and excludes installment of term loans repayable within 12 months.
- Long term Debts represent debts other than Short term Debts as defined above but includes installment of term loans repayable within 12 months grouped under other current liabilities
- The figures disclosed above are based on restated statement of Assets and Liabilities of the Company as at 31.12.2013 and 31.03.13.

ANNEXURE - P
STATEMENT OF MANDATORY ACCOUNTING RATIOS

(Amt. In ₹)

Particulars	As at					
	31-12-13	31-03-13	31-03-12	31-03-11	31-03-10	31-03-09
Face Value per equity Share(₹)	10.00	10.00	10.00	10.00	10.00	10.00
Earnings/ (losses) Per Share (in ₹)						
-Basic and Diluted Earnings/ (losses) Per Share [a/b]	3.08	36.35	(10.33)	7.13	8.72	13.82
(ii) Return on Net Worth (in %) [a/d]	0.16	0.40	(0.84)	0.18	0.29	0.61
(iii) Net Assets Value per Share (in ₹) [d/c]	19.19	16.11	6.98	38.53	30.40	20.68
(a) Net profit available for appropriation (as restated)	3079879.93	6413947.79	587191.06	71258.96	87171.71	126830.08
(b) Weighted average numbers of equity shares for calculating Basic and diluted EPS.	1000000.00	176438.36	56849.32	10000.00	10000.00	9178.08
(c) No. of equity shares outstanding at the end of the year.	1000000.00	1000000.00	100000.00	10000.00	10000.00	10000.00
(d) Net Worth as at the end of the period/year	19191897.40	16112017.47	698069.68	385260.75	304001.79	206830.08

Notes:

1. The above ratios are calculated as under:

$$\text{a) Basic and Diluted Earning per Share} = \frac{\text{Net Profit available for appropriation (as restated)}}{\text{Weighted average number of equity shares outstanding during the year}}$$

$$\text{b) Return on Net Worth(\%)} = \frac{\text{Net Profit available for appropriation (as restated)}}{\text{Net worth as at the year end}}$$

$$\text{c) Net Asset Value Per Equity Share} = \frac{\text{Net Worth as at the end of the period/year}}{\text{Number of equity shares outstanding at the end of the Year}}$$

2. Net Worth means the aggregate of the paid up share capital, share premium account, and reserves and surplus (excluding revaluation reserve) as reduced by the aggregate of miscellaneous expenditure (to the extent not adjusted or written off) and the debit balance of the profit and loss account;

3. Earnings Per Share (EPS) calculation are in accordance with the Accounting Standard 20 "Earnings Per Share" prescribed under the Companies (Accounting Standards) Rules, 2006.

4. The figures disclosed above are based on the restated financial information of the Company.

5. Basic and Diluted EPS for the period ended 31st December 2013 are not annualised.

ANNEXURE - Q

STATEMENT OF TAX SHELTER

(Amount in ₹)

Particulars	For the Year / period ended					
	31-Dec-13	31-Mar-13	31-Mar-12	31-Mar-11	31-03-10	31-03-09
Restated Profit before tax	4832246.92	8946173.54	(512985.91)	112596.30	126152.53	183545.91
MAT Rate	18.50%	18.50%	18.50%	18.00%	15.00%	10.00%
Normal Tax Rate	30.00%	30.00%	30.00%	30.00%	30.00%	30.00%
Normal Tax on above	1449674.08	2683852.06	(153895.77)	33778.89	37845.76	55063.77
Adjustments:						
<i>Permanent Differences:</i>						
ROC fees for increase in authorized share capital	900000.00	175000.00	22000.00	0.00	0.00	0.00
<i>Temporary Difference:</i>						
Difference between Book Depreciation & Tax Depreciation	2512084.41	1671153.76	684267.25	26016.13	19943.85	11963.85
Provision for Gratuity	24209.00	32125.00	0.00	0.00	0.00	0.00
<i>Other Adjustments:</i>						
Brought Forward Losses adjusted	0.00	(418105.00)	0.00	0.00	0.00	0.00
Total Adjustments	3436293.41	1460173.76	706267.25	26016.13	19943.85	11963.85
Tax expense/(saving) thereon	1030888.02	438052.13	211880.18	7804.84	5983.16	3589.16
<i>Total Tax Payable:</i>						
Tax Payable for the current year under normal tax - (a)	2480562.10	3121904.19	57984.40	41583.73	43828.91	58652.93
Tax Payable as per MAT	893965.68	1655042.10	(94902.39)	20267.33	18922.88	18354.59
Maximum of (a) and (b)	2480562.10	3121904.19	57984.40	41583.73	43828.91	58652.93
Add : Edu Cess and Higher Edu Cess	74416.86	93657.13	1739.53	1247.51	1314.87	1759.59
Total Tax Payable	2554978.96	3215561.32	59723.94	42831.24	45143.78	60412.52

STATEMENT OF FINANCIAL INDEBTEDNESS

Brief details on the financial indebtedness of Bansal Roofing Products Limited “the Company” as on May 15, 2014 is as under:

Secured Loans

(Amount in ₹ Lakhs)

Name of Lender	Nature & Purpose of Loan	Amount Sanctioned	Amount outstanding	Rate of Interest p. a.	Repayment Schedule	Securities Offered
State Bank of India	Cash Credit for working Capital	200.00	119.56	Base Rate (10% Currently) + 3.75%	On Demand	See Note 1 Below
HDFC Bank Ltd.	Vehicle Loan for purchase of Maruti Ecco	3.17	1.98	11.50%	36 EMI of ₹ 10,454 each	Hypothecation of Vehicle (Maruti Ecco Chassis no. 282646)

Note 1

Prime Security	Hypothecation of entire Stocks and Book Debts
Collateral Securities	Immovable Security
	Equitable Mortgage over Shop No. 1-9, Behind Shivam Hotel, Dabhoi Road, Kapurai Crossing, Vadodara of area measuring 11464 Sq. Feet owned by Mr. Kaushalkumar S. Gupta
	Personal Guarantees
	Mr. Kaushalkumar S. Gupta
	Mr. Satishkumar S. Gupta
	Mrs. Sangeeta K. Gupta
	Mr. Ashishkumar S. Gupta

Unsecured Loan

Name and Relationship of Lender	Purpose	Rate of Interest	Repayment	Outstanding Amount
Mr. Kaushalkumar S. Gupta (Promoter of the Company)	Business	Nil	3 Months	82,00,000.00

Restrictive covenants pertaining to facility of Cash Credit:

1. Effect any change in the company’s capital structure;
2. Implement any scheme of expansion / modernization / diversification / renovation or acquire fixed assets except during any accounting year, except such schemes those indicted in the funds flow statement submitted to the Bank from time to time and approved by Bank.
3. Formulate any scheme of amalgamation or reconstruction.
4. Invest by way of the share capital in or lend or advance funds to or place deposits with any other concern including sister / associate / family / subsidiary / group concerns. However, normal trade credit or security deposits in the normal course of businesses or advances to employees can be excluded.
5. Enter into borrowing arrangement either secured or unsecured with any other bank, financial institution, Company or person.
6. Undertake guarantee obligation on behalf of any other company, firm or person.
7. Declare the dividends of any year except out of profit relating to that year after making all due and necessary provisions and provided further that no default had occurred in any repayment obligations.
8. Effect any drastic changes in the management setup.
9. Effect any change in the remuneration payable to the Directors / partners etc. either in the form of sitting fees or otherwise.
10. Pay guarantee commission to the guarantor whose guarantee have been stipulated / furnished for the credit limits sanctioned by the bank.

Bansal Roofing Products Limited

11. Create further charge, lien or encumbrance over the assets and properties of the unit / guarantors to be charged / charged to the bank in favor of any other financial institution, bank, company, firm or person.
12. Sell assign, mortgage or otherwise dispose off any of fixed assets charged to the Bank.
13. Undertake any trading activity other than the sale of product arising out of its own manufacturing operations.
14. Open any account with any other bank. If already opened the details thereof is to be given immediately and a confirmation to this effect given to the bank.

For Santlal Patel & Co.

Chartered Accountants

Firm Registration No. 113888W

Sd/-

CA. Santlal C. Patel

Proprietor

M. No. 47612

Date: May 15, 2014

Place: Vadodara

The Statutory Auditor of the Company M/s. Santlal Patel & Co., Chartered Accountants, vide their Certificate dated May 29, 2014 have certified that there is no audit qualification in the financial statements of Bansal Roofing Products Limited.

MANAGEMENT'S DISCUSSION AND ANALYSIS OF FINANCIAL CONDITION AND RESULTS OF OPERATIONS

You should read the following discussion of our financial condition and results of operations together with our restated financial statements included in this Prospectus. You should also read the section entitled “Risk Factors” beginning on page 11 and “Forward Looking Statements” beginning on page 10, which discusses a number of factors, risks and contingencies that could affect our financial condition and results of operations.

The following discussion of our financial condition and results of operations should be read in conjunction with our restated summary statements as of and for the fiscal years ended March 31, 2009, 2010, 2011, 2012, 2013 and 9 months period ended December 31, 2013, including the schedules and notes thereto and the reports thereon, which appear in the section titled “Financial Information of the Company” on Page No. 113 of this Prospectus. The financial statements presented and discussed herein have been prepared to comply in all material respects with the notified accounting standards by Companies (Accounting Standards) Rules, 2006 (as amended), the relevant provisions of the Companies Act and SEBI (Issue of Capital and Disclosure Requirements) Regulations. Our fiscal year ends on March 31 of each year. Accordingly, all references to a particular fiscal year/financial year are to the twelve-month period ended on March 31 of that year. The forward-looking statements contained in this discussion and analysis is subject to a variety of factors that could cause actual results to differ materially from those contemplated by such statements.

We are mainly a manufacturer of roofing sheets and roofing accessories such as Colour Coated Roof Sheets, FRP Roof Sheets, Polycarbonate Sheets. We also manufacture Eco Ventilators and other miscellaneous Roofing Accessories and provide all roofing solutions our valuable customers, under one roof. We believe that we have built domain expertise in roofing solutions in a short span which has contributed in our business growth. Promoters of our Company have been associated with roofing industry since more than a decade.

Our Company was incorporated in 2008, with foraying into business of marketing of roofing sheets and started trading of the same afterwards. We have started our commercial production in the year 2012, since than our continued rapid growth is a testament to the certainty, our Customers experience every day.

Registered office of our Company is at 3/2, Labdhi Industrial Estate, Acid Mill Compound, Ranmukteshwar Road, Pratapnagar, Vadodara, 390004, Gujarat, India.

Our manufacturing facility is situated at Plot No. 06, Raj Industrial Estate, Vadadala, Near Samlatya Crossing, Vadodara, 391520, Gujarat. The products manufactured by our Company are made on automatic and semi automatic Roll forming machine, Crimping Machine, Shearing Machine and folding machine.

OUR COMPETITIVE STRENGTH

We believe that the following are our primary competitive strength:

1. Experienced Management Team

We benefit from the leadership of our management team, which has extensive experience in roofing industry. Our Promoters have more than adequate experience in roofing industry and we have successfully grown under their efficient leadership in the past. Our Promoters are actively involved in our operations and bring to our Company their vision and leadership which we believe has been instrumental in sustaining our business operations. Our Company feels that the strength of any successful organization lies in the experience and guidance of its team leaders and staff alike. Our key managerial personnel are largely responsible for successful execution our growth strategy by developing new customer base and strengthening our customer relationships.

2. Strong Range of Products, Strong Brand Image

Over the years we have strengthened our products portfolio in order to address the varied and expanding requirement of our customers. Our products portfolio include Colour Coated Roof Sheets, FRP Roof Sheets, Polycarbonate Sheets, Turbo Ventilators and other miscellaneous Roofing Accessories. We believe that our product portfolio allow our customers to source all products under one roof to fulfil their roofing requirements, which helps us to expand our business from existing customers as well as address potential new customers. We believe our products portfolio provide our customers one stop solution for their roofing requirements

Over the years we have successfully developed a strong and reliable brand image for our Company, which provides us a competitive edge over other competitor.

3. Quality Assurance and Standards

We believe in providing our customers the best possible quality. All products that leave the factory premise goes through stringent quality check. Also, quality check is done at every stage of manufacturing to ensure the adherence to desired specifications. Since, our Company is dedicated towards quality of products, processes and inputs; we get repetitive orders from our buyers, as we are capable of meeting their quality standards.

4. Extensive and Cost beneficial Manufacturing Facility

Our manufacturing facility has all good facility. We believe that this enables us to control costs and increase our profit margins and gives us a competitive advantage over some of our competitors who do not have their own manufacturing facilities. We believe that our large skilled workforce with knowledge and expertise in roofing industry is a key competitive strength that has enabled us to establish and maintain our reputation and brand.

OUR BUSINESS STRATEGY

1. Increasing our geographical reach

Roofing markets have shown increased growth with many projects coming up in real estates, infrastructural developments. With thrust in the development of core infrastructure we believe there are ample opportunities available for us to cater to the ever expanding requirement. Accordingly we promote our products in India as well as in African markets through our marketing managers and executives, who help in understanding client requirements and oversee execution into desired products.

2. Focus on Cordial relations with our Suppliers, Customers and employees

We believe in developing and maintaining long term sustainable relationships with our suppliers, consumers and employees which will help us in achieving the goals set, particularly in view of entering in to new markets. We offer wide range of products at competitive prices, which will help us achieve consumer satisfaction and build long term relationships, which will translate into repeated sales.

3. To build-up a professional organization

As an organization we believe in transparency and commitment in our work among our work force and with our suppliers, customers, government authorities, banks, financial institutions etc. We have employed experienced persons for taking care of our day to day activities. We also consult with outside agencies on a case to case basis on technical and financial aspects of our business. Hence, the philosophy of professionalism is foundation stone of our business strategy and we wish to make it more sound and strong in times to come.

SWOT ANALYSIS

Strength

- ✓ Experienced, technically sound Management
- ✓ Insights of Industry
- ✓ Total solutions to customers

Weakness

- ☒ Dependency on economic growth of national economy at large
- ☒ Capital Intensive industry
- ☒ Low margin,

Opportunities

- ✓ Boon in Core Infrastructure development
- ✓ Potential to add capacity in the existing facility
- ✓ Increasing interest for metal roofing

Threat

- Volatile Raw material pricing
- Competition from cash rich companies

FUTURE PROSPECTS

Backward Integration

Currently, we purchase color coated galvanized steel rolls from our suppliers. However, in future we intend to purchase only steel rolls and to color those sheets at our end. Further we intend to move towards galvanizing steel rolls from cold rolls, converting hot rolls into cold rolls gradually, which will enable us to decrease our dependency on our raw material suppliers and taking our business to new levels.

MARKETING STRATEGY

Our Company is based in Gujarat. We use print media advertisements, pamphlets for local area distribution, Newspaper advertisements in local publications with a view to create a visibility. Further, the Company has planned a marketing strategy Audio Promotion via radio channels, Print Promotion- Newspaper Ads, Posters, Online Promotion through Internet; and Freebies like Vouchers. Our Marketing Manager and export manager has also extensively marketed our product in African country which will help us in increasing our production.

Key factors affecting our results of Operation

1. General economic and business conditions in India and in the markets in which our company operate and in the local, regional, national and international economies;
2. Increased competition in these sectors/areas in which we operate;
3. Changes in laws and regulations relating to the industry in which we operate;
4. Our ability to compete with and adapt to the technological advances;
5. Changes in political, economic and social conditions in India;
6. Fluctuations in the operating costs;
7. Changes in the foreign exchange control regulations, interest rates and tax laws in India;
8. Our ability to attract and retain qualified personnel;
9. Our ability to meet our capital expenditure requirements; and
10. Any adverse outcome in the legal proceedings in which we may be involved.
11. Market fluctuations and industry dynamics beyond our control;
12. Occurrence of natural disasters or calamities affecting the areas in which we have operations;
13. Conflicts of interest with affiliated companies, the promoter group and other related parties; and
14. Contingent Liabilities, environmental problems and uninsured losses;

Our Significant Accounting Policies:

Our significant accounting policies are described in the section entitled “*Financial Information of the Company*” on page 113 of this Prospectus.

Change in accounting policies in previous 3 (three) years

Except as mentioned in chapter Restated Financial Statements on page no. 113 there has been no change in accounting policies in last 3 (three) years.

SUMMARY OF THE RESULTS OF OPERATION

The following table sets forth select financial data from standalone restated profit and loss accounts for the 9 months period ended December 31, 2013 & Financial Year 2013, 2012, 2011 & 2010 and the components of which are also expressed as a percentage of total income for such periods.

Bansal Roofing Products Limited

(Amount in ₹)

Particulars	for 9 months period ended		For the Year ended							
	31.12.13	% of Total In-come	31.03.13	% of Total In-come	31.03.12	% of Total In-come	31.03.11	% of Total In-come	31.03.10	% of Total In-come
Revenue from Operations:										
Revenue from sale of product	141157650.29	100	171550783.37	100	7084759.11	100	672794.80	100	448638.00	99.65
Total Revenue from Operations	141157650.29	100	171550783.37	100	7084759.11	100	672794.80	100	448638.00	99.65
Other Income	6562.00	0.00	0.00	0.00	0.00	0.00	0.00	0.00	1583.25	0.35
Total Revenue	141164212.29	100	171550783.37	100	7084759.11	100	672794.80	100	450221.25	100
Expenses:										
Cost of Sale	129301526.15	91.60	175038417.78	102.03	10579194.81	149.32	83900.50	12.47	127631.00	28.35
Change in inventories of finished goods, WIP	(1526931.22)	(1.08)	(17984867.84)	(10.48)	(4244096.00)	(59.90)	0.00	0.00	0.00	0.00
Employee benefits expense	3073796.00	2.18	2180191.00	1.27	540912.00	7.63	354619.75	52.71	165000.00	36.65
Finance costs	744835.06	0.53	192440.97	0.11	9273.75	0.13	275.75	0.04	0.00	0.00
Depreciation and amortization expense	467433.55	0.33	510489.31	0.30	72263.80	1.02	4738.13	0.70	4738.13	1.05
Preliminary Expenses written off	0.00	0.00	0.00	0.00	0.00	0.00	10000.00	1.49	10000.00	2.22
Other expenses	4,271,305.83	3.03	2,667938.61	1.56	640196.66	9.04	106664.38	15.85	16,699.60	3.71
Total Expenses	136331965.37	96.58	162604609.83	94.79	7597745.02	107.24	560198.51	83.26	324068.73	71.98
Net Profit before tax exceptional & extra-ordinary items:	4832246.92	3.42	8946173.54	5.21	(512985.91)	(7.24)	112596.30	16.74	126152.53	28.02
Exceptional & extra-ordinary items:	0.00	0.00	0.00	0.00	0.00	0.00	0.00	0.00	0.00	0.00
Net Profit before tax	4832246.92	3.42	8946173.54	5.21	(512985.91)	(7.24)	112596.30	16.74	126152.53	28.02
Provision for Tax										
- Current Tax	1500000.00	1.06	2108010.00	1.23	0.00	0.00	32916.00	4.89	36,515.00	8.11
Tax adjustment for prior years	0.00	0.00	0.00	0.00	0.00	0.00	6545.00	0.97	0.00	0.00
-Deferred Tax Liability / (Asset)	252366.99	0.18	424215.75	0.25	74205.15	1.05	1876.33	0.28	2465.82	0.55
Restated profit after tax	3079879.93	2.18	6413947.79	3.74	(587191.06)	(8.29)	71258.96	10.59	87171.71	19.36

KEY COMPONENTS OF OUR PROFIT AND LOSS STATEMENT

Revenue from operations

Revenue from operations primarily consists of the sale of products and Labour Incomes. Sale of products includes the sale of Colour Coated Roof Sheets, FRP Roof Sheets, Polycarbonate Sheets and Eco Ventilators and other miscellaneous Roofing Accessories.

Other income

Other income primarily comprises interest income, and bank charges etc.

Expenses

Our expenses majorly consist of cost of material and stores consumed purchases of stock in trade, employee benefits expense, finance costs, depreciation and amortization expense, preliminary expenses written off and other expenses.

Cost of Sale:

Cost of Sale the cost of raw material and components used in the manufacturing of our products.

Changes in inventories of finished goods, WIP and stock-in-trade

Changes in inventories of finished goods, WIP and stock-in-trade consist of the difference between the inventory at the beginning of the period and inventory at the end of the period.

Employee benefits expense

Employee benefit expense includes salaries and wages, staff welfare expenses, bonus and performance incentive.

Finance Costs

Finance cost comprises interest on indebtedness, bank and other Finance charges.

Depreciation and amortization expense

We recognize depreciation and amortization expense on a Written down value method as per the rates set forth in the Companies Act except for some items for which depreciation is charged as per our accounting policy.

Other expenses

Other expenses consist primarily of various charges like electricity charges, sales promotion expenses, repairs and maintenance expenses, other, rent, rates and taxes, legal, professional and consultancy charges. Other items in this category include travelling expenses, conveyance expenses, postage and courier charges, communication expenses, auditors' remuneration, insurance charges, vehicle expenses, office expenses, printing and stationery expenses.

FINANCIAL PERFORMANCE HIGHLIGHTS FOR THE 9 MONTHS PERIOD ENDED DECEMBER 31, 2013

Revenue from Operations:

Our income from operations during the 9 months period ended December 31, 2013 was ₹ 141,157,650.29. The operating revenue mainly comprised of revenue from sale of product and labour income amounting to ₹ 141,157,650.29 which was 100% of our Total Revenue.

Other Income:

Other income of the Company was ₹ 6,562 which primarily consists of Interest income.

Total Expenses:

The total expenditure during the 9 months period ended December 31, 2013 was ₹ 136,331,965.37. The total expenditure represents 96.58% of the total revenue for the period. The total expenses is majorly represented by cost of Sale, employee benefits expense, finance costs, depreciation expense, preliminary expenses written off, other expenses for administrative and selling and distribution. The main constituent of total expenditure is cost of sale, which is ₹ 129,301,526.15.

Profit after tax:

Our restated net profit during the 9 months period was ₹ 3,079,879.93 representing 2.18% of the total revenue of our Company. Our provision of current taxes for 9 months period ended December 31, 2013 was ₹ 1,500,000

COMPARISON OF THE FINANCIAL PERFORMANCE OF FISCAL 2013 WITH FISCAL 2012

Revenue from Operations:

During the F.Y. 2013 the total income of the Company increased to ₹ 171,550,783.37 as against previous financial year ₹ 7,084,759.11. The income from sale of products increased to ₹ 171,550,783.37 from ₹ 7,084,759.11, an increase of 95.87%. This increase was mainly due to increase in sale of products.

Total Expenses:

Total expenditure for the F.Y. 2013 increased to ₹ 162,604,609.83 from ₹ 7,597,745.02 compared to the previous financial year, increasing by 95.32%. This was due to surge in volume of business, which resulted in increase in expenses viz. consumption of materials, direct expenses and employees benefit expenses.

Cost of sale:

Cost of sale for the F.Y. 2013 amounted to ₹ 175,038,417.78 as against ₹ 10,579,194.81 compare to previous financial year. In percentage terms it amounted to 102.03% of the total income as against 149.32% in the previous year. Increased in cost of sale was attributable to our increased demand in F.Y 2013, compared to the previous financial year.

Change in inventories of finished goods, WIP:

Inventories in F.Y 2013 were ₹ (17,984,867.84) as against ₹ (4,244,096) for previous year, which was 10.48% of the total income as against 59.90% of total income in the previous year.

Employee benefits expense:

Employee benefits expense increased to ₹ 2,180,191 from ₹ 5, 40,912 in the year F.Y 2013 i.e. 75.19%. This was also due to increase in business activities and rise in revenue of the Company.

Finance costs:

Finance costs increase to ₹ 192,440.97 in F.Y 2013 as compare to F.Y 2012 in which it was ₹ 9,273.75.

Depreciation and amortization expense:

Depreciation and amortization expense increased to ₹ 510,489.31 from 72,263.80 compare to previous year.

Other expenses:

Other expenses for the F.Y 2013 stood at ₹ 2,667,938.61; the same was ₹ 640,196.66 in previous financial year.

Net Profit before tax:

Net Profit before tax for the F.Y 2013 increased to ₹ 8,946,173.54 as against the loss of ₹ (512,985.91) of the previous year. The increase in profit was due to growth in revenue.

Restated profit after tax:

The Restated profit after tax for the F.Y 2013 stood at ₹ 6,413,947.79, compare to F.Y 2012 the loss was ₹ (587,191.06).

COMPARISON OF THE FINANCIAL PERFORMANCE OF FISCAL 2012 WITH FISCAL 2011

Revenue from Operations:

During the F.Y. 2012 the total income of the Company increased to ₹ 7,084,759.11 as against previous financial year ₹ 672,794.80. This is majorly due to increase in revenue from sale of products amounted to ₹ 7,084,759.11 from ₹ 672,794.80, an increase of 90.50%. This increase was mainly due to increase in sale of products.

Cost of Sale:

Cost of sale amounted to ₹ 10,579,194.81 for F.Y. 2012 as against ₹ 83,900.50 in F.Y. 2011. In percentage terms, it amounted to 149.32% of the total income as against 12.47% in the previous year.

Change in inventories of finished goods, WIP:

Inventories in F.Y 2012 were ₹ (4,244,096) as against ₹ Nil for previous year as we have started our manufacturing activities in current year only.

Employee benefits expense:

Employee benefits expense increased to ₹ 540,912 from ₹ 354,619.75 in the F.Y. 2012 i.e. 34.44%. This was due to surge in volume of business, which resulted in increased expenses.

Finance costs:

Finance costs increase to ₹ 9,273.75 in F.Y. 2012 as compare to F.Y. 2011 in which it was ₹ 275.75.

Depreciation and amortization expense:

Depreciation and amortization expense increased to ₹ 72,263.80 in F.Y. 2012 from 4,738.13 compare to previous year..

Other expenses:

Other expenses for the F.Y. 2012 stood at ₹ 640,196.66 where as in F.Y. 2011 the same was ₹ 106,664.38.

Total Expenses:

Total expenditure for the F.Y. 2012 increased to ₹ 7,597,745.02 from ₹ 560,198.51, compare to previous financial year, increase of 92.63%. This was due to surge in volume of business, which resulted in increase in expenses viz. consumption of materials, direct expenses, employees provision and administration expenses.

Net Profit before tax:

Our company has incurred Net Loss before tax for the F.Y. 2012 which was ₹ (512,985.91) as against ₹ 112,596.30 Net profit before tax of the previous year.

Restated profit after tax:

Our company has incurred Net Loss before tax for the F.Y. 2012 which was ₹ (587,191.06), compared to F.Y 2011 when there was a profit after tax it was ₹ 71,258.96.

COMPARISON OF THE FINANCIAL PERFORMANCE OF FISCAL 2011 WITH FISCAL 2010

Revenue from Operations:

During the F.Y. 2011 the total income of the Company increased to ₹ 672,794.80 as against previous financial year ₹ 450,221.25. increase of 33.08%. This is majorly due to increased in revenue from sale of products amounted to ₹ 672,794.80 from ₹ 448,638.

Other Income:

No Other income of the Company in F.Y. 2011 as against ₹ 1,583.25 in F.Y. 2010.

Cost of sale:

Cost of sale for the F.Y. 2011 amounted to ₹ 83,900.50 as against ₹ 127,631 in previous financial year. It amounts to 12.47% of the total income as against 28.35% in the previous year.

Employee benefits expense:

The employee benefits expense increased to ₹ 354,619.75 from ₹ 165,000 in the F.Y. 2011 i.e. 53.47%.

Finance costs:

Finance costs increase to ₹ 275.75 in F.Y. 2011 as compare to F.Y. 2010 in which it was Nil.

Depreciation and amortization expense:

The Depreciation and amortization expense are same to ₹ 4,738.13 in F.Y. 2011 of ₹ 4738.13 compare to previous year.

Other expenses:

Other expenses for the F.Y. 2011 stood at ₹ 106,664.38 where as in F.Y. 2010 the same was ₹ 16,699.60.

Total Expenses:

Total expenditure for the F.Y. 2011 increased to ₹ 560,198.51 from ₹ 324,068.73, compare to previous financial year, increase of 42.15%. This was due to surge in volume of business, which resulted in increase in expenses viz. consumption of materials, direct expenses, employees provision and administration expenses.

Net Profit before tax:

Net Profit before tax for the F.Y 2011 decreased to ₹ 112,596.30 as against ₹ 126,152.53 of the previous year.

Restated profit after tax:

The Restated profit after tax for the F.Y 2011 stood at ₹ 71,258.96, compare to F.Y 2011 it was ₹ 87,171.71.

Information required as per Item (2) (IX) (E) (5) of Part A of Schedule VIII to the SEBI Regulations:

An analysis of reasons for the changes in significant items of income and expenditure is given hereunder:

1. Unusual or infrequent events or transactions

There has not been any unusual trend on account of our business activity. There are no Unusual or infrequent events or transactions in our Company. The transactions are as per usual business operations.

2. Significant economic changes that materially affected or are likely to affect income from continuing operations.

There are no significant economic changes that may materially affect or likely to affect income from continuing operations.

3. Known trends or uncertainties that have had or are expected to have a material adverse impact on sales, revenue or income from continuing operations.

Apart from the risks as disclosed under Section “**Risk Factors**” beginning on page 11 in the Prospectus, in our opinion there are no other known trends or uncertainties that have had or are expected to have a material adverse impact on revenue or income from continuing operations.

4. Future changes in relationship between costs and revenues

Our Company’s future costs and revenues will be determined by demand/supply situation, government policies and prices quoted by raw material suppliers.

5. Increases in net sales or revenue and Introduction of new products or services or increased sales prices

Increases in revenues are by and large linked to increases in volume of business.

6. Status of any publicly announced New Products or Business Segment

Our Company has not announced any new product or business segment.

7. Seasonality of business

Our Company’s business is not seasonal in nature.

8. Dependence on a single or few customers/ clients

The % of contribution of our Company’s top 10 customers/clients & top 10 suppliers for 9 months period ended December 31, 2013 are as follows:

Our Major Customers/ Clients for the 9 months period ended December 31, 2013

Name of the Clients	Amount (₹ in Lacs)	As % of total Sales
Agrawal Associates	302.33	21.52%
Steel Smith Continental Mfg. Pvt. Ltd.	55.98	3.98%
Aster Building Solutions Pvt. Ltd.	38.59	2.75%
Meghmani Finechem Limited	16.67	1.19%
Urmi Traders	15.47	1.10%
Kraft Laminate	14.86	1.06%
Trimurti Interiors	14.13	1.01%
Grippon Profiles & Engineering Pvt. Ltd.	14.05	1.00%
Iso Therm Puf Panel Pvt. Ltd.	12.41	0.88%
Samirika Infrastructure Pvt. Ltd.	12.40	0.88%
Total	496.89	35.37%

Our Major Suppliers for the 9 months period ended December 31, 2013

Name of the Supplier	Amount (₹ in Lacs)	As % of total Purchase
Manaksia Limited	829.90	64.92%
Indian Steel Corporation Ltd.	263.84	20.64%
Bhushan Steel Limited	77.20	6.04%
Steel Smith Continental Mfg. Pvt. Ltd.	33.08	2.59%
Reichhold India Pvt. Ltd.	19.25	1.51%
Asarco Steel Pvt. Ltd.	8.62	0.67%
Aaryan Composities	8.57	0.67%
Pennar Industries Limited	7.88	0.62%
Jsk Industries Pvt. Ltd.	3.57	0.28%
Primacy Systems Pvt. Ltd.	3.28	0.26%
Total	1255.19	98.19%

Competitive conditions

Competitive conditions are as described under the Chapters “*Industry Overview*” and “*Our Business*” beginning on pages 66 and 72, respectively of the Prospectus.

Details of material developments after the date of last balance sheet i.e. December 31 2013

Except as mentioned below, no circumstances have arisen since the date of last financial statement until the date of filing the Prospectus, which materially and adversely affect or are likely to affect the operations or profitability of our Company, or value of its assets, or its ability to pay its liability within next twelve months. There is no subsequent development after the date of the Auditor’s Report, which will have a material impact on the reserves, profits, earnings per share and book value of the Equity Shares of the Company. Significant developments since the last audited balance sheet as on December 31, 2013 till the date of this Prospectus:

1. Our Company has issued Bonus shares in the ratio of 12:1 to our equity shareholders except Mr. Kaushalkumar S. Gupta. For further details of the same please see chapter titled “*Capital Structure*” beginning on page no. 39.

SECTION VI: LEGAL AND OTHER INFORMATION

OUTSTANDING LITIGATION AND MATERIAL DEVELOPMENTS

Except as stated in this Prospectus, there is no outstanding or pending litigation, suit, criminal or civil prosecution, proceeding initiated for offence (irrespective of whether specified in paragraph (I) of Part I of Schedule XIII of the Companies Act) or litigation for tax liabilities against our Company, our Directors or our Promoters or companies promoted by our Promoters and there are no defaults to banks/financial institutions, non-payment of or overdue statutory dues, or dues towards holders of any debentures, bonds and fixed deposits and arrears of preference shares, other unclaimed liabilities of our Company and no disciplinary action has been taken by SEBI or any stock exchanges against our Company, our Promoters or Directors. Further, except as stated in this Prospectus, there are no past cases in which penalties have been imposed on our Company or our Promoters, Directors or companies promoted by the Promoters by concerned authorities, and there is no outstanding litigation against any other company whose outcome could have a material adverse effect on the position of our Company.

Neither our Company nor its Promoters, members of the Promoter Group, Subsidiary, associates and Directors have been declared as willful defaulters by the RBI or any other Governmental authority and, except as disclosed in this section in relation to litigation, there are no violations of securities laws committed by them in the past or pending against them.

PART I – Contingent Liabilities of Our Company

As on date, in our opinion there are no contingent liabilities of our Company except that our Company has filed compounding application before Regional Director, Registrar of Companies, North-western Region Bench, Ahmadabad, for certain non-compliances in relation to section 211 of the Companies Act, 1956. Pending request for compounding, the amount of liability cannot be determined as on date.

PART II – LITIGATIONS RELATING TO OUR COMPANY

A. Cases filed against our Company

1. Litigation involving Civil Laws

i. *Mukesh Kumar Ramanlal Shah v/s Hitesh Dinesh Chnadra Shah Anr. (Suit no 149/2010 in the Court No. 13 of Senior Civil Judge at Vadodara)*

A civil suit bearing no. 149/2010 was filed by Mr. Mukesh Kumar Ramanlal Shah before the Hon'ble Court of Senior Civil Judge at Vadodara, to cancel the sale deed dated March 28, 2008 and obtain necessary possession of the land as mentioned in the suit. In relation to the same a legal notice was sent by Thakrani & Company on behalf of its client Shri Mukesh Kumar Ramanlal Shah addressed to Bansal Roofing Pvt. Ltd. (hereinafter mentioned as the "Company") and other 15 entities. The Company is noticee no. 9th in the said notice. The Notice states that the property situated at survey no. 42/16 belonged to one Mr. Bhailalbhai Haribhai Desai and after his death the same was transferred to one Dayabhai Bhailalbhai Desai. Subsequently Dayabhai sold the said property to two entities one White Way Products (Parma) Ltd. and another, Shri Mukesh Kumar Ramanlal Shah admeasuring 27500 sq meters, vide a sale deed no. 1246 dated September 9, 1993. Subsequently, Mr. Mukesh Kumar Ramanlal Shah sold, through an agreement to sale, 6600 sq. meters of land to M/s Bio Vascular and the remaining land admeasuring 20900.75 sq. meters to one Shri Dharmesh Kumund Chandra Shah and Shri Kumudchandra Bhikhabhai Jain for an amount of ₹ 17,97,465.00 (Rupees Seventeen Lacs Ninety Seven Thousand Four Hundred Sixty Five Only) and they had paid ₹ 7,00,000.00 (Rupees Seven Lacs Only) as token amount, with a promise that the remaining amount shall be paid by December 22, 1999, and if they fail to pay the same, the sale shall stand cancelled and as per the events, they were not able to pay the amount and therefore the sale was cancelled. Thereafter it has been alleged that, one Mr. Hitesh Dineshchandra Shah and other forged the Power of Attorney of Mr. Mukesh Kumar Ramanlal Shah and sold the said property vide a sale deed, on March 28, 2008 to (1) Kalpesh Ramanlal Thakkar, (2) Manish Govrdhandas Pujara, (3) Mitul Jagdishchandra Ganatra (4) Navin Chimanbhai Raval. It is been alleged that these person knowingly and deliberately executed the said sale deed to defraud the rights of Mr. Mukesh Kumar Ramanlal and subsequently Company purchased the land from the said entities. Subsequently a *lis-pendence* is also lodged in the office of Sub-Registrar at Savli. It was further stated that, Mr. Kalpesh Ramanlal Thakkar and others have illegally taken the possession and occupation of the property and executed a development agreement with Raj Industrial Park. Apart from filling suit no 149/2010. Mr. Mukesh Kumar Ramanlal also filed a criminal complaint in the Savli police station against Shri Hitesh Dinesh Chnadra Shah,

Shri Dineshchandra Nagindas Shah, Mr. Kalpesh Ramanlal Thakkar, Manish Govardhan Pujara, Mr. Mitul Jagdishchandra Ganatra. It is also stated that, the Company along with other entities have cheated Mr. Mukesh Kumar Ramanlal by executing the development agreement and subsequent sale deeds. It is also alleged that, the Company and other entities have misrepresented the government authorities in regarding the ownership of the land and stamp duty. Though, the Company is not party to the instant suit but it is in possession of the instant land and also operates its business from the same. Presently, the matter is pending before the concerned Court and evidences by the parties are going on. The next date in the matter is on July 9, 2014.

ii. **Central bank of India v/s White Way Products (Pharma) Limited anr. (Suit no. 578/2000 at Debt Recovery Tribunal, Ahmadabad)**

A recovery suit was filed by Central Bank of India (hereinafter referred to as “Bank”) against White Way Products (Pharma) Limited (hereinafter referred to as “White way”) bearing suit application no 578/2000 wherein it was stated that the Bank had provided a loan amount of ₹ 30,00,000.00 to White way in lieu of mortgaged being created on the land property admeasuring 16623.25 sq. mtrs and hypothecated its plant and machineries including building on the land and an undertaking was given by the White Way Products (Pharma) Limited and its directors that, without the express consent of the Bank they will not sale, gift, mortgage or transfer the property in favour of any third party. But the White way sold the instant property to the Company by keeping the Bank in dark and causing huge losses to it. For recovery of the same the Bank approached the Debt Recovery Tribunal at Ahmadabad and filed the instant suit and accordingly an order was passed by the Debt Recovery Tribunal in favour of the Bank to auction the property and recover its dues, but the Bank was not successful in doing the same. Subsequently, this property was transferred to the Company and Company is operating its factory premises on this property. However, due to a settlement reached between the previous owner and the bank, the bank has issued a NO DUES CERTIFICATE dated October 1, 2013 in favour of White way thereby adjusting the dues payable to the Bank and in relation to the same, an application was also filed by the Bank with Debt Recovery Tribunal for withdrawal of the recovery proceedings initiated by it. Subsequently, on the application made by the Bank, the Hon’ble Debt Recovery Tribunal vide its order dated March 24, 2014 ordered for withdrawal of recovery proceedings against White way in application bearing no. 17/5. However, the final order in the matter is awaited.

2. **Litigation involving Criminal Laws**
Nil
3. **Litigation involving Securities and Economic Laws**
Nil
4. **Litigation involving Labour Laws**
Nil
5. **Litigation involving Taxation**
Ni

B. Cases filed by our Company

1. **Litigation involving Civil Laws**

i. **M/s. Raj Industrial Development Corporation Anr. V/s. Central Bank Anr. (Suit No. RS/144/2011 Before the Hon’ble Civil Judge, Court at Savli)**

A Regular suit bearing no. RS/144/2011 for Permanent injunction was filed by Mr. Kaushal Gupta (Promoter of the Company) and Ors against Central Bank of India and Ors. The plaintiffs in the matter stated that, they possess the ownership right over the property, which is situated on survey no. 42/16/A/part 2 admeasuring 16623 sq. meters. It is further stated that, Plaintiff no. 1, i.e. Raj Industrial Development Corporation has an absolute development right over the property and the same was granted to it vide a development agreement dated November 29, 2010, executed between him and the Original Owners (i.e. Mr. Kalpesh Ramanlal Thakkar, Ms. Ritaben Thakkar, Ms. Nimiskaben Dineshchandra Thakkar and Mr. Archiben Dinesh Chandra Thakkar). Subsequently, the plaintiff through individual sale deed purchased the respective part of land from the Original Owners. White way Pharma Products Ltd (hereinafter referred to as the **Defendant no. “2”**) had purchased the said property from one Dayabhai Bhailalbhai Desai and later on the property was transferred to

Defendant no. 3 and then 4. Thereafter vide a sale deed dated September 01, 2010 the instant property was sold to Kalpesh Ramanlal Thakkar, who in turn sold the property to the Plaintiffs. The Defendant no. 2 had taken loan from Central Bank of India (hereinafter referred to as “**Defendant no. “1”**”) and hypothecated the property which was later on sold to Mr. Ami Dhiren Shah and Swatiben Bhargavbhai Patel (hereinafter referred to as the **Defendant no. “3”** and “**4,”** respectively”). Now, Defendant No. 1 wants to create a mortgage over the property and for the same it had sent notices on October 19, 2010 and September 20, 2010. The Plaintiff has sought the directions from the Court to injunct the Defendant No. 1 from registering in mortgage on the Property. However in view of compromise with the Central Bank of India Plaintiff No. 1 had filed withdrawal pursis vide Exh. 14 on November 23, 2013. The said is kept for next hearing by Ld. Civil Judge, Savli on July 21, 2014.

2. Litigation involving Company Laws

i. Before Regional Director, North Western Region Branch, Ahmedabad of Registrar of Companies

M/s. Bansal Roofing Products Limited, (hereinafter referred to as “the **Company**”) failed to comply with certain provisions of Companies Act, 1956 till FY 2012-13 since its incorporation, the Company was operating on a very small scale till the financial year 2012-13, with highest revenue being ₹ 70.84 Lac only in F.Y. 2011-12, it had not inducted any expert for the purpose of accounting and preparation of financial statements and that the accounting was done by person having working knowledge of accounting. Therefore, there were certain discrepancies while preparing financial statements in consonance with Accounting Standards resulting in non-compliance of Section 211 of Companies Act, 1956 for the period since incorporation till F.Y. ending 2012-13. However the Company has made necessary corrections in the books of accounts for the financial year beginning on April 01, 2013. However in relation to the Non-compliances Company has filed suo-moto compounding application vide SRN: C03928322 on May 22, 2014 and physical Application have also been submitted on May 22, 2014 before Regional Director, Registrar of Companies, North-western Region Bench, Ahmadabad.

3. Litigation involving Criminal Laws

Nil

4. Litigation involving Securities and Economic Laws

Nil

5. Litigation involving Labour Laws

Nil

6. Litigation involving Taxation

Nil

C. Notices from Statutory Authorities

i. Notice Under Section 135D of Land Revenue Code, from Talati

A Notice dated September 12, 2012 was served upon: (1) Jagdish chandra, (2) Ramanlal, (3) Gordhanbhai, Muje Vaddalal, Taluka Savli District: Vadodara and (4) Bansal Roofing Pvt. Ltd. (hereinafter mentioned as the “**Company**”). The said Notice states that, the authorities has made an alteration entry in the property card of record no.6 and asked the noticees to file their representation within 30 days in case they have any dispute or objection to the same. The alteration was made to give effect the sale of the open land which belonged to one Shri Kalpesh Ramanlal Thakkar and other having survey no.42/16/A/Part/1 and 42/16/A/Part/2, out of the entire plot no. 6, plot admeasuring an area of 1755.sq.mtrs, common plot and common road of the share having area 245.64 sq. meter. The instant property was sold to the Company vide sale deed dated August 05, 2011. The Company has not taken any steps in relation to the abovementioned notice.

ii. Notice under section 156 of Income Tax Act, 1961

The Income Tax Department has raised demand of ₹ 6,660.00 for the assessment year 2010-11. Which is outstanding till date.

PART III – LITIGATIONS RELATING TO THE DIRECTORS OTHER THAN PROMOTERS OF THE COMPANY

A. Cases filed against the Directors

1. **Litigation involving Civil/Statutory Laws**
Nil
2. **Litigation involving Criminal Laws**
Nil
3. **Litigation involving Economic Offenses**
Nil
4. **Litigation involving Tax Liabilities**
Nil

B. Cases filed by the Directors

1. **Litigation involving Civil/Statutory Laws**
Nil
2. **Litigation involving Criminal Laws**
Nil
3. **Litigation involving Economic Offenses**
Nil
4. **Litigation involving Tax Liabilities**
Nil

PART IV – LITIGATIONS RELATING TO OUR PROMOTER AND PROMOTER GROUP ENTITIES

A. Cases filed against the Promoter and Promoter Group entities

1. **Litigation involving Civil/Statutory Laws**
Nil
2. **Litigation involving Criminal Laws**
Nil
3. **Litigation involving Economic Offenses**
Nil

B. Cases filed by the Promoter and Promoter Group entities

1. Litigation involving Civil Laws

- i. Agarwal Associate v/s Sawan Engineers Private Limited, (Suit bearing no. 918/2011 before Civil Judge, Vadodara)*

The Agarwal Associate (a proprietary concern of our Promoter Mr. Kaushal Gupta) (hereinafter referred to as “ the **Petitioner**”), had delivered certain goods to M/s. Sawan Engineers Pvt. Ltd. (hereinafter referred to as “ the **Defendant**”) for which payment was due from the Defendant. When, after repeated requests, the payment was not made, a legal notice dated September 30, 2011 sent by Mr. Ankit K. Shah (Advocate) on behalf of the petitioner, for recovery of the payment. In relation to the same, a Recovery suit bearing no. 918/2011, dated December 21, 2011 was instituted by the Petitioner against the Defendant before Civil Judge, Vadodara, for recovery of the amount of ₹ 3,69,353.00 (₹ Three Lacs Sixty Nine Thousand Three Hundred Fifty Three Only). In the instant matter disposition by Mr. Kaushal Gupta was submitted on

February 5, 2013 and the matter is still pending before the concerned Court wherein next date of hearing is July 11, 2014.

2. Litigation involving Criminal Laws

i. State v/s Nitinbhai Karsanbhai Luhar Anr. (C.S. No. 4081/2004 in I Court, Vadodara)

A FIR was filed by Mr. Kaushal Gupta (hereinafter referred to as the “**Complainant**”) which had been registered under **Sec. 323, 504, 506 (2), 114 of Indian Penal Code 1860 and u/s 135 of B.P. Act.** It was reported to the police by the Complainant, that the Complainant had delivered certain goods to Karsanbhai Lohar of Yogesh Engineering for which payment was due from him. When he went to his place to recover the same, heated arguments took place between them. Later that day, accused no.1 Mr. Nitinbhai Karsanbhai Luhar and accused no.2 Mr. Bholabhai Narsinghbhai Luhar and accused no.3 Buttiwalo and some unknown persons came to Complainant’s office and abused him and accused no.1 hit Complainant with a iron pipe on wrist of his hand, while accused no.2 hit Complainant with iron pipe on left leg, there by injuring him severely and they also gave him threatening of life. Subsequently the Complainant filed the instant FIR in Wadi Police Station, Vadodara City. The instant matter came to be registered as C.S. No. 4081/2004 in Ist Court, Vadodara wherein a summon dated November 20, 2007 was issued to Mr. Kaushal Gupta to present himself before Court for giving evidence in the instant matter. Subsequently the matter was transferred to Additional Metropolitan Magistrate 13th Court, Vadodara. Presently the matter is still pending before the concerned Court wherein Non-bailable warrants have been issued against the accused persons and bailable warrant has been issued to Complainant for appearance. Next date of hearing in the matter is June 27, 2014

ii. FIR dated February, 3, 2007

A FIR was filed by Mr. Kaushal Gupta (hereinafter referred to as “the **Complainant**”) which was registered under Sec. 279 & 427 of Indian Penal Code, 1860 and u/s 177, 184, 134 of The Motor Vehicles Act, 1988. It was reported to the police by Complainant that he was driving his Hyundai Accent Car No. GJ 6CB 2609 towards Savli Manjusar where he stopped at Kalaghoda traffic signal and when the said signal opened a three wheeler tempo No. GJ 6Z 9771 drove very carelessly on wrong side and struck the Complainant’s car thereby causing scratch on the car near left bonnet side and ran away.

3. Litigation involving Securities and Economic Laws

Nil

4. Litigation involving Labour Laws

Nil

5. Litigation involving Taxation

i. M/S Agarwal Associate V/s Commissioner of Customs, Central Excise, Vadodara II

The Agarwal Associate (a proprietary concern of our Promoter Mr. Kaushal Gupta) (hereinafter referred to as “Appellant”) has preferred an appeal bearing Appeal No. ST/602/2010) & (Stay No. ST/S-1696/10-DB) before Custom, Excise & Service Tax Appellate Tribunal, West Zone Bench: Ahmadabad. The Appeal has been preferred by the Appellant against the order bearing no. OIR/No.05/VDR-II/S.TAX/AGARWAL-ASSO/COMMR/2010 dated August 24, 2010 of Commissioner of Customs and Excise-Vadodara-II. The Appellant was provided an opportunity of being heard on December 11, 2011. During the course of hearing , the stay application of the Company was rejected and Company was directed to deposit ₹ 1,00,000 and pursuant to that, the Company has deposited the relevant amount and the appeal is pending before the concerned court.

C. Notices received from Statutory Authorities

i. Intimation under section 143(1) of Income Tax Act, 1961

Our Promoter Mr. Kaushalkumar S. Gupta has received intimation under section 143(1) of from CPC Bangalore in the month of April 2013, demanding tax of ₹ 146780.00. Our promoter has filed a rectification request saying there was a mistake on Income Tax Departments end while calculating the profit. However due to technical reason our request could not be processed. CA. Santlal C. Patel, on behalf of Mr.

Bansal Roofing Products Limited

Kaushalkumar S. Gupta, wrote to Asst. Commissioner of Income Tax, Circle - 2(1), Vadodara to this fact and inviting his attention to the mistake of software at CPC Bangalore’s end simultaneously requesting rectify the order and delete the demand raised by CPC Bangalore. However till date the demand had been outstanding and our promoter has not received further intimation in this regard.

PART V – AMOUNTS OWED TO SMALL SCALE UNDERTAKINGS AND OTHER CREDITORS

Our Company has not received any information from its suppliers regarding their registration under the ‘Micro, Small and Medium Enterprises Development Act, 2006’. Hence the information required to be disclosed under Section 22 of the Micro, Small and Medium Enterprises Development Act, 2006; i.e. amounts owed to creditors including small scale undertakings, which is outstanding for more than 30 days as on December 31, 2013 cannot be determined.

The list of creditors as on December 31, 2013, which is outstanding for more than 30 days exceeding ₹ 1.00 lacs as stated below:-

(Amount in ₹)		
Sr. No.	Name of the Creditor	Amount outstanding for more than 30 Days
1.	Manaksia Limited	1,44,18,967.10
2.	Mipra Steel	1,23,616.00
3.	Steel Smith Continental Mfg. Pvt. Ltd.	5,48,573.00

PART VI - MATERIAL DEVELOPMENTS

Except as mentioned below, no circumstances have arisen since the date of last financial statement until the date of filing the Prospectus, which materially and adversely affect or are likely to affect the operations or profitability of our Company, or value of its assets, or its ability to pay its liability within next twelve months. There is no subsequent development after the date of the Auditor’s Report, which will have a material impact on the reserves, profits, earnings per share and book value of the Equity Shares of the Company. Significant developments since the last audited balance sheet as on December 31, 2013 till the date of this Prospectus:

1. Our Company has issued Bonus shares in the ratio of 12:1 to our equity shareholders except Mr. Kaushalkumar S. Gupta. For further details of the same please see chapter titled “*Capital Structure*” beginning on page no. 39.

WE CERTIFY THAT EXCEPT AS STATED HEREIN ABOVE:

- a. there are no pending proceedings for offences for non-payment of statutory dues by the promoters of the Company.
- b. there are no cases of litigation pending against the Company or against any other Company in which Directors are interested, whose outcome could have a materially adverse effect on the financial position of the Company.
- c. there are no pending litigation against the promoters/ directors in their personal capacities and also involving violation of statutory regulations or criminal offences.
- d. there are no pending proceedings initiated for economic offences against the Directors, Promoters, Companies and firms promoted by the promoters.
- e. there are no outstanding litigation, defaults etc. pertaining to matters likely to affect the operations and finances of the Company including disputed tax liability or prosecution under any enactment.
- f. there are no litigations against the promoters / Directors in their personal capacity.
- g. the Company, its promoters and other Companies with which promoters are associated have neither been suspended by SEBI nor any disciplinary action has been taken by SEBI.
- h. as per the audited Balance sheet as December 31, 2013 there are no SSI units to whom, our Company owns any sum which is outstanding for more than 30 days.

GOVERNMENT AND OTHER APPROVALS

Our Company has received the necessary consents, licenses, permissions and approvals from the Government and various governmental agencies required for its present business (as applicable on date of this Prospectus) and except as mentioned below, no further approvals are required for carrying on its present business.

In view of the approvals listed below, our Company can undertake this Issue and its Current/Proposed Business activities and no further major approvals from any Governmental or Regulatory Authority or any other entity are required to be undertaken in respect of the Issue or continue its present business activities. It must be distinctly understood that, in granting these approvals, the Government of India does not take any responsibility for the Company's financial soundness or for the correctness of any of the statements made or opinions expressed in this behalf. Unless otherwise stated, these approvals are all valid as of the date of this Prospectus.

The main objects clause of the Memorandum of Association and objects incidental to the main objects enable the Company to carry out its business activities. The following statement sets out the details of licenses, permissions and approvals taken by us under various central and state laws for carrying out business.

I. Approvals for the Issue

The following approvals have been obtained or will be obtained in connection with the Issue:

- a. The Board of Directors has, pursuant to a resolution adopted in its meeting held on January 09, 2014 authorized the Issue, subject to the approval of the shareholders of our Company under Section 81 & 81(1A) of the Companies Act, 1956 and such other authorities as may be necessary.
- b. The shareholders of our Company have, pursuant to a resolution under Section 81 & 81 (1A) of the Companies Act, 1956 adopted at an Extra Ordinary General Meeting held on January 20, 2014, authorized the further issue of Equity Shares.
- c. NSDL/CDSL: ISIN No.: INE319Q01012

II. Incorporation and Other Details

Sr. No.	Nature of License / Approval	Registration/ License No.	Issuing Authority	Date of granting License/ Approval	Validity
1.	Certificate of Incorporation in the name of Bansal Roofing Private Limited	U25206GJ2008PTC053761	The Registrar of Companies, Gujarat, Dadra & Nagar Havelli	May 01, 2008	--
2.	Fresh Certificate of Incorporation consequent upon change of name of our Company from "Bansal Roofing Private Limited" to Bansal Roofing Products Private Limited.	U25206GJ2008PTC053761	The Registrar of Companies, Gujarat, Dadra & Nagar Havelli	August 29, 2013	--
3.	Fresh Certificate of Incorporation on change of name of our Company from " Bansal Roofing Products Private Limited " to " Bansal Roofing Products Limited " pursuant to conversion into a public limited company	U25206GJ2008PLC053761	The Registrar of Companies, Gujarat, Dadra & Nagar Havelli	November 19, 2013	--

III. Tax Related Approvals

Sr. No.	Nature of License / Approval	Registration/ License No.	Issuing Authority	Date of granting License/ Approval	Validity
1.	Permanent Account Number (PAN)	AADCB4379B	Income Tax Department	May 01, 2008	One Time Registration
2.	Tax Deduction Account Number (TAN)\$	BRDB02042F	Income Tax Department	September 08, 2009	One Time Registration
<p><i>\$ For Tax Deduction Account Number (TAN), on change of name of our Company pursuant to Conversion from private to public Company, we have applied to the relevant issuing authority for issuance of new certificates in the new name. However we are yet to receive the fresh certificates.</i></p> <p>Application bearing no. 05006470000593 For Tax Deduction Account Number (TAN) made on April 25, 2014.</p>					
3.	Central Sales Tax Registration	24691202069	Commercial Tax Officer, Unit 5, Vadodara	September 07, 2011*	One Time Registration
<p>**Amended Certificate has been issued upon name change on December 19, 2013.</p>					
4.	Value Added Tax Act, 2003	24191202069	Commercial Tax Officer (Commercial Tax Department, Government of Gujarat) Unit 5, Vadodara	August 4, 2010**	One Time Registration
<p>**Amended Certificate has been issued upon name change on December 19, 2013.</p>					
5.	Central Excise Registration Certificate under Rule 9 of the Central Excise Rules, 2002,	AADCB4379BEM001	Assistant Commissioner, Central Excise & Customs, City Division, Vadodara-II. Central Board of Excise and Custom	February 7, 2012***	One Time Registration
<p>***Amended Certificate has been issued upon name change on January 24, 2014.</p>					
6.	Service Tax Registration under Section 69 of the Finance Act, 1994 (32 of 1994)	AADCB4379BSD001	Superintendent (Service Tax), Central Excise & Customs, City Division, Head Quarters, Vadodara-II	September 6, 2011****	One Time Registration
<p>****Amended Certificate has been issued upon name change on February 03, 2014</p>					
7.	Professional Tax Registration under sub-section (1) of Section 5 of the Gujarat State Tax on Professions, Trades, Callings and Employment Act, 1976	PER – 19090800674	Profession Tax Commissioner , Savli	March 24, 2014*****	One Time Registration
<p>*****The original certificate was issued on March 28, 2012 with registration no. PEP-19090960452</p>					

IV. Business Related Approvals

Sr. No.	Nature of License / Approval	Registration/ License No.	Issuing Authority	Date of granting License/ Approval	Validity
1.	Certificate of Importer-Exporter Code (IEC)	3411003413	Foreign Trade Development Officer, Office of Joint Director General of Foreign Trade (Vadodara), Department of Commerce, Ministry of Commerce & Industry, GoI.	September 7, 2011	One Time Registration
2.	Employees Provident Fund Registration#	GJ/BRD/68051	Assistant Provident Fund Commissioner, Regional Office, Vadodara, Employees Provident Fund Organisation, Ministry of Labour & Employment, GoI	April 07, 2013	One Time Registration
3.	Certificate of Registration under Contract Labour (Regulation & Abolition) Act, 1970#	1330/2011	Assistant Labour Commissioner, Vadodara	August 20, 2011	One Time Registration
<p># For Certificate of Registration under Contract Labour (Regulation & Abolition) Act, 1970 and Employees Provident Fund Registration, on change of name of our Company pursuant to Conversion from private to public Company, we have applied to the relevant issuing authority for issuance of new certificates in the new name.. However we are yet to receive the fresh certificates.</p> <p>Application made on:- For Employees Provident Fund Registration:- November 20, 2013 For Certificate of Registration under Contract Labour (Regulation & Abolition) Act, 1970:- February 15, 2014</p>					
4.	Registration Certificate of Establishment under Bombay Shops and Establishments Act, 1948.	B -26/17305	Inspector under the Bombay Shops and Establishments Act, 1948, Vadodara Municipal Corporation Shops and Establishments Branch	May 19, 2011 (Renewed on December 27, 2013)	December 31, 2016
5.	Registration as Small Scale Enterprise	EM2 24 019 12 004682	District Industries Centre, Vadodara, Govt. of Gujarat	December 16, 2013	One Time Registration
6.	Provisional Consent Order (CTE)	CTE - 14675	Gujarat Pollution Control Board	December 27, 2013	December 26, 2018.

V. Other Approvals

Sr. No.	Nature of License / Approval	Registration/ License No.	Issuing Authority	Date of granting License/ Approval	Validity
1.	Govt. Purchase Enlistment Certificate	NSIC/GP/RS/PMT/GUJ/ B-137/2013-14/ A-66.	The National Small Industries Corporation Limited	March 31, 2014	Dec 5, 2014
2.	ISO 9001 : 2008 for Manufacture and supply of Color Coated Roofing Sheets and its allied Accessories	GUJ /Q –1857	Nimbus Certifications Private Limited (An accredited certificate authorised for issued by Accreditation Services for	June 28, 2012, (Reissued January 07, 2014)	June 27, 2015

Bansal Roofing Products Limited



Sr. No.	Nature of License / Approval	Registration/ License No.	Issuing Authority	Date of granting License/ Approval	Validity
			Certifying Bodies (Europe) Limited)		
3.	Approved supplier of stores in Western Railway	19914	Deputy Chief Materials Manager (CMR), Controller of Stores, Western Railway	February 27, 2013	February 27, 2015
4.	Approved supplier of stores in Central Railway	13013472	Secretary to Controller of Stores, Central Railway, C.S.T., Mumbai -1	September 23, 2013	September 23, 2014

VI. Pending Approvals

Business Related Approvals

Sr. No.	Nature of License / Approval	Registration/ License No.	Issuing Authority	Date of Application	Status
1.	Factories License	13613	Joint Director, Directorate Industrial Safety & Health Gujarat State, Vadodara	October 23, 2013	Expired, Applied, Pending for renewal.

Approvals Relating to Intellectual Property

Sr. No.	Particulars of Mark	Word/ Label	Applicant	Date of filing	Application No.	Class	Status
1.		Label	Bansal Roofing Products Limited	March 6, 2014	2693319	19	Awaited for registration
2.		Label	Bansal Roofing Products Limited	March 6, 2014	2693320	6	Awaited for registration

OTHER REGULATORY AND STATUTORY DISCLOSURES

Authority for the Issue

The Board of Directors has, pursuant to a resolution adopted at its meeting held on January 09, 2014 authorized the Issue, subject to the approval of the shareholders of our Company under Section 81 & 81(1A) of the Companies Act, 1956, and such other authorities as may be necessary.

The shareholders of our Company have, pursuant to a resolution under Section 81 & 81(1A) of the Companies Act, 1956 at an Extra Ordinary General Meeting held on January 20, 2014, authorized the further issue of Equity Shares.

Our Company has obtained in-principle approval from the SME Platform of BSE for using its name in the Prospectus pursuant to letter dated June 6, 2014. BSE is the Designated Stock Exchange.

Prohibition by SEBI, RBI or governmental authorities

Our Company, Promoter, Promoter Group, Directors, Group Entities or the person(s) in control of our Company have not been prohibited from accessing the capital market for any reason or restrained from buying, selling or dealing in securities, under any order or directions by the SEBI or any other authorities and there are no violations of securities laws committed by any of them in the past or pending against them, nor have any companies with which any of our Company, our Promoter, Directors, persons in control of our Company or any natural person behind the Promoter are or were associated as a promoter, director or person in control, been debarred or prohibited from accessing the capital markets under any order or direction passed by the SEBI or any other authority.

Association with Securities Market

None of our Directors are associated with the securities market and there has been no action taken by the SEBI against the Directors or any other entity with which our Directors are associated as promoters or directors.

Prohibition by RBI

None of our Company, Promoter, Directors, Group Entities, relatives (as per Companies Act, 1956) of Promoter or the person(s) in control of our Company have been identified as a will full defaulter by the RBI or other governmental authority and there has been no violation of any securities law committed by any of them in the past and no such proceedings are pending against any of them except as details provided in the chapter "***Outstanding Litigations, Material Development***" beginning on page 151 of the Prospectus.

Eligibility for the Issue

Our Company is eligible for the Issue in accordance with Regulation 106(M)(1) and other provisions of Chapter XB of the SEBI (ICDR) Regulations, as we are an Issuer whose post issue paid up capital is less than ₹ 10 Crores and we may hence issue Equity Shares to the public and propose to list the same on the Small and Medium Enterprise Exchange (in this case being the "***SME Platform of BSE***").

We confirm that:

1. In accordance with Regulation 106(P) of the SEBI (ICDR) Regulations, this issue is 100% underwritten and that the LM to the Issue Shall underwrite minimum 15% of the Total Issue Size. For further details pertaining to said underwriting please refer to section titled "***General Information – Underwriting***" beginning on page 36 of this Prospectus.
2. In accordance with Regulation 106(R) of the SEBI (ICDR) Regulations, that the total number of proposed allottees in the Issue shall be greater than or equal to fifty (50), otherwise, the entire application money will be refunded forthwith. If such money is not repaid within eight (8) Working Days from the date our Company becomes liable to repay it, then our Company and every officer in default shall, on and from expiry of eight (8) Working Days, be liable to repay such application money, with an interest at the rate of 15% per annum as prescribed under the Companies Act.
3. In accordance with Regulation 106(O) the SEBI (ICDR) Regulations, we have not filed any Draft of this Offer Document with SEBI nor has SEBI issued any observations on our Offer Document. Also, we shall ensure that

Bansal Roofing Products Limited

our LM submits a copy of the Prospectus along with a Due Diligence Certificate including additional confirmations as required to SEBI at the time of filing the Prospectus with Stock Exchange and the Registrar of Companies.

4. In accordance with Regulation 106(V) of the SEBI (ICDR) Regulations, we hereby confirm that we have entered into an agreement with the LM and a Market Maker to ensure compulsory Market Making for a minimum period of three years from the date of listing of Equity Shares on the SME Platform of BSE. For further details of the arrangement of market making please refer to section titled "**General Information – Details of the Market Making Arrangements for this Issue**" beginning on page 37 of this Prospectus.

We further confirm that we shall be complying with all the other requirements as laid down for such an issue under Chapter XB of SEBI (ICDR) Regulations, as amended from time to time and subsequent circulars and guidelines issued by SEBI and the Stock Exchange.

As per Regulation 106(M)(3) of SEBI (ICDR) Regulations, the provisions of Regulations 6(1), 6(2), 6(3), Regulation 7, Regulation 8, Regulation 9, Regulation 10, Regulation 25, Regulation 26, Regulation 27 and sub-regulation (1) of Regulation 49 of SEBI (ICDR) Regulations shall not apply to us in this Issue.

Our Company is also eligible for the Issue in accordance with eligibility norms for listing on SME Exchange Platform BSE laid down under circular dated April 19, 2012 (<http://www.bsesme.com/aboutpublicissue.aspx>), which states as follows:

1. Net Tangible Assets of at least ₹ 1 Crore as per the latest audited financial results (as restated).

(₹)

Particulars	31.12.2013	31.03.2013	31.03.2012	31.03.2011
Non-current assets				
Tangible Fixed assets (Net Block) excluding Revaluation Reserve, if any	16,471,172.19	14,770,950.44	13,785,868.35	87,275.10
Non-current investments	0.00	0.00	0.00	0.00
Long-term loans and advances	43,944.00	41,544.00	41,544.00	0.00
Other non-current assets	0.00	0.00	0.00	0.00
Current Assets				
Inventories	23,755,895.06	22,228,963.84	4,244,096.00	0.00
Trade Receivables	3,047,743.00	19,580,877.00	744,902.00	349,073.90
Cash & Bank Balances	3,861,541.26	460,891.78	564,484.81	712,517.56
Short Term Loans & Advances	4,617,619.98	155,370.63	338,938.00	0.00
Other Current Assets	5,088,725.41	3,187,002.29	1,310,081.81	116,426.17
Total Non-current & Current Assets (A)	56,886,640.90	60,425,599.98	21,029,914.97	1,265,292.73
Non Current Liabilities				
Long-term borrowings	8,317,392.67	14,414,860.97	14,200,000.00	700,000.00
Long-term provisions	0.00	0.00	0.00	0.00
Current liabilities				
Short-term borrowings	6,050,931.85	3,396,113.00	0.00	0.00
Trade payables	15,496,812.10	22,989,766.65	5,956,995.15	102,562.00
Other current liabilities	5,514,446.00	699,915.00	54,729.00	36,515.00
Short-term provisions	1,556,334.00	2,306,467.00	37,877.00	32,916.00
Total Non Current Liabilities and Current Liabilities (B)	36,935,916.62	43,807,122.62	20,249,601.15	871,993.00
Net Tangible Assets (A-B)	19,950,724.28	16,618,477.36	780,313.82	393,299.73

Net tangible assets are defined as the sum of all net assets of the Company, excluding intangible assets as defined in Accounting Standard 26 (AS 26) issued by the Institute of Chartered Accountants of India.

2. Net worth (excluding revaluation reserves) of at least ₹ 1 crore as per the latest audited financial results (as restated).

(₹)

Particulars	31.12.2013	31.03.2013	31.03.2012	31.03.2011
Share Capital	10,000,000.00	10,000,000.00	1,000,000.00	100,000.00
Add: Reserves & Surplus	9,191,897.40	6,112,017.47	(301,930.32)	285,260.75
Less: <i>Miscellaneous</i> to the extent not written off	0.00	0.00	0.00	0.00
Net Worth	19,191,897.40	16,112,017.47	698,069.68	385,260.75

Bansal Roofing Products Limited

Net worth includes Equity Share Capital and Reserves (excluding revaluation reserves), Miscellaneous Expenditure not written off, if any. & Debit Balance of Profit and Loss Account not written off, if any)

3. Track record of distributable profits in terms of sec. 205 of Companies Act, 1956 for at least two years out of immediately preceding three financial years and each financial year has to be a period of at least 12 months. Extraordinary income will not be considered for the purpose of calculating distributable profits. Otherwise, the Net Worth shall be at least ₹ 3 Crores.

The Company has distributable profits in terms of sec. 205 of Companies Act, 1956(as restated), as detailed below:

Particulars	31.12.2013	31.03.2013	31.03.2012	31.03.2011
Net Profit (as restated) – Standalone	3,079,879.93	6,413,947.79	(587,191.06)	71,258.96

4. The post-issue paid up capital of our Company shall be at least ₹1 Crores. As detailed in Chapter Capital Structure of this Prospectus, our Company will have a post issue capital of ₹ 2,19,72,000.00.
5. Our Company shall mandatorily facilitate trading in demat securities and enter into an agreement with both the depositories. The Company with Registrar to the Issue has entered into such agreements with the Central Depository Services Limited (CDSL) and the National Securities Depository Limited (NSDL) on March 18, 2014 and March 27, 2014.
6. Our Company has a website i.e. www.bansalroofing.com.
7. Our Company has not been referred to the Board for Industrial and Financial Reconstruction (BIFR).
8. There is no winding up petition against our Company that has been admitted by the Court or a liquidator has not been appointed.
9. There has been no change in the promoter/s of the Company in the preceding one year from date of filing application to BSE for listing on SME segment.

We confirm that we comply with all the above requirements / conditions so as to be eligible to be listed on the SME Platform of the BSE.

Compliance with Part A of Schedule VIII of the SEBI (ICDR) Regulations

Our Company is in compliance with the provisions specified in Part A of the SEBI (ICDR) Regulations. No exemption from eligibility norms has been sought under Regulation 109 of the SEBI (ICDR) Regulations, with respect to the Issue. Further, our Company has not been formed by the conversion of a partnership firm into a company.

DISCLAIMER CLAUSE OF SEBI

IT IS TO BE DISTINCTLY UNDERSTOOD THAT SUBMISSION OF OFFER DOCUMENT TO THE SECURITIES AND EXCHANGE BOARD OF INDIA (SEBI) SHOULD NOT IN ANY WAY BE DEEMED OR CONSTRUED THAT THE SAME HAS BEEN CLEARED OR APPROVED BY SEBI. SEBI DOES NOT TAKE ANY RESPONSIBILITY EITHER FOR THE FINANCIAL SOUNDNESS OF ANY SCHEME OR THE PROJECT FOR WHICH THE ISSUE IS PROPOSED TO BE MADE OR FOR THE CORRECTNESS OF THE STATEMENTS MADE OR OPINIONS EXPRESSED IN THE OFFER DOCUMENT. THE LEAD MERCHANT BANKER, HEM SECURITIES LIMITED HAS CERTIFIED THAT THE DISCLOSURES MADE IN THE OFFER DOCUMENT ARE GENERALLY ADEQUATE AND ARE IN CONFORMITY WITH THE SEBI (ISSUE OF CAPITAL AND DISCLOSURE REQUIREMENTS) REGULATIONS, 2009 IN FORCE FOR THE TIME BEING. THIS REQUIREMENT IS TO FACILITATE INVESTORS TO TAKE AN INFORMED DECISION FOR MAKING INVESTMENT IN THE PROPOSED ISSUE.

IT SHOULD ALSO BE CLEARLY UNDERSTOOD THAT WHILE THE ISSUER IS PRIMARILY RESPONSIBLE FOR THE CORRECTNESS, ADEQUACY AND DISCLOSURE OF ALL RELEVANT INFORMATION IN THE OFFER DOCUMENT, THE LEAD MERCHANT BANKER, HEM SECURITIES LIMITED IS EXPECTED TO EXERCISE DUE DILIGENCE TO ENSURE THAT THE ISSUER DISCHARGES ITS RESPONSIBILITY ADEQUATELY IN THIS BEHALF AND TOWARDS THIS PURPOSE, THE LEAD

MERCHANT BANKER HAS FURNISHED TO SEBI A DUE DILIGENCE CERTIFICATE DATED JUNE 16, 2014 WHICH READS AS FOLLOWS:

WE, THE UNDER NOTED LEAD MANAGER TO THE ABOVE MENTIONED FORTHCOMING ISSUE STATE AND CONFIRM AS FOLLOWS:

- 1. WE HAVE EXAMINED VARIOUS DOCUMENTS INCLUDING THOSE RELATING TO LITIGATION LIKE COMMERCIAL DISPUTES, PATENT DISPUTES, DISPUTES WITH COLLABORATORS, ETC. AND OTHER MATERIAL IN CONNECTION WITH THE FINALISATION OF THE PROSPECTUS PERTAINING TO THE SAID ISSUE**
- 2. ON THE BASIS OF SUCH EXAMINATION AND THE DISCUSSIONS WITH THE ISSUER, ITS DIRECTORS AND OTHER OFFICERS, OTHER AGENCIES, AND INDEPENDENT VERIFICATION OF THE STATEMENTS CONCERNING THE OBJECTS OF THE ISSUE, PRICE JUSTIFICATION AND THE CONTENTS OF THE DOCUMENTS AND OTHER PAPERS FURNISHED BY THE ISSUER, WE CONFIRM THAT:**
 - A. THE PROSPECTUS FILED WITH THE BOARD IS IN CONFORMITY WITH THE DOCUMENTS, MATERIALS AND PAPERS RELEVANT TO THE ISSUE;**
 - B. ALL THE LEGAL REQUIREMENTS RELATING TO THE ISSUE AS ALSO THE REGULATIONS GUIDELINES, INSTRUCTIONS, ETC. FRAMED/ISSUED BY THE BOARD, THE CENTRAL GOVERNMENT AND ANY OTHER COMPETENT AUTHORITY IN THIS BEHALF HAVE BEEN DULY COMPLIED WITH; AND**
 - C. THE DISCLOSURES MADE IN THE PROSPECTUS ARE TRUE, FAIR AND ADEQUATE TO ENABLE THE INVESTORS TO MAKE A WELL INFORMED DECISION AS TO THE INVESTMENT IN THE PROPOSED ISSUE AND SUCH DISCLOSURES ARE IN ACCORDANCE WITH THE REQUIREMENTS OF THE COMPANIES ACT, 2013, APPLICABLE PROVISIONS OF THE COMPANIES ACT, 1956, THE SECURITIES AND EXCHANGE BOARD OF INDIA (ISSUE OF CAPITAL AND DISCLOSURE REQUIREMENTS) REGULATIONS, 2009 AND OTHER APPLICABLE LEGAL REQUIREMENTS.**
- 3. WE CONFIRM THAT BESIDES OURSELVES, ALL THE INTERMEDIARIES NAMED IN THE PROSPECTUS ARE REGISTERED WITH THE BOARD AND THAT TILL DATE SUCH REGISTRATION IS VALID.**
- 4. WE HAVE SATISFIED OURSELVES ABOUT THE CAPABILITY OF THE UNDERWRITERS TO FULFILL THEIR UNDERWRITING COMMITMENTS.**
- 5. WE CERTIFY THAT WRITTEN CONSENT FROM PROMOTER HAS BEEN OBTAINED FOR INCLUSION OF THEIR SPECIFIED SECURITIES AS PART OF PROMOTERS' CONTRIBUTION SUBJECT TO LOCK-IN AND THE SPECIFIED SECURITIES PROPOSED TO FORM PART OF PROMOTERS' CONTRIBUTION SUBJECT TO LOCK-IN SHALL NOT BE DISPOSED / SOLD / TRANSFERRED BY THE PROMOTER DURING THE PERIOD STARTING FROM THE DATE OF FILING THE PROSPECTUS WITH THE BOARD TILL THE DATE OF COMMENCEMENT OF LOCK-IN PERIOD AS STATED IN THE PROSPECTUS.**
- 6. WE CERTIFY THAT REGULATION 33 OF THE SECURITIES AND EXCHANGE BOARD OF INDIA (ISSUE OF CAPITAL AND DISCLOSURE REQUIREMENTS) REGULATIONS, 2009, WHICH RELATES TO SPECIFIED SECURITIES INELIGIBLE FOR COMPUTATION OF PROMOTERS CONTRIBUTION, HAS BEEN DULY COMPLIED WITH AND APPROPRIATE DISCLOSURES AS TO COMPLIANCE WITH THE SAID REGULATION HAVE BEEN MADE IN THE PROSPECTUS.**
- 7. WE UNDERTAKE THAT SUB-REGULATION (4) OF REGULATION 32 AND CLAUSE (C) AND (D) OF SUB-REGULATION (2) OF REGULATION 8 OF THE SECURITIES AND EXCHANGE BOARD OF INDIA (ISSUE OF CAPITAL AND DISCLOSURE REQUIREMENTS) REGULATIONS, 2009 SHALL BE COMPLIED WITH. WE CONFIRM THAT ARRANGEMENTS HAVE BEEN MADE TO ENSURE THAT PROMOTERS' CONTRIBUTION SHALL BE RECEIVED AT LEAST ONE DAY BEFORE THE OPENING OF THE ISSUE. WE UNDERTAKE THAT AUDITORS' CERTIFICATE TO THIS EFFECT SHALL BE**

DULY SUBMITTED TO THE BOARD. WE FURTHER CONFIRM THAT ARRANGEMENTS HAVE BEEN MADE TO ENSURE THAT PROMOTERS' CONTRIBUTION SHALL BE KEPT IN AN ESCROW ACCOUNT WITH A SCHEDULED COMMERCIAL BANK AND SHALL BE RELEASED TO THE ISSUER ALONG WITH THE PROCEEDS OF THE PUBLIC ISSUE. – NOT APPLICABLE

- 8. WE CERTIFY THAT THE PROPOSED ACTIVITIES OF THE ISSUER FOR WHICH THE FUNDS ARE BEING RAISED IN THE PRESENT ISSUE FALL WITHIN THE 'MAIN OBJECTS' LISTED IN THE OBJECT CLAUSE OF THE MEMORANDUM OF ASSOCIATION OR OTHER CHARTER OF THE ISSUER AND THAT THE ACTIVITIES WHICH HAVE BEEN CARRIED OUT UNTIL NOW ARE VALID IN TERMS OF THE OBJECT CLAUSE OF ITS MEMORANDUM OF ASSOCIATION.**
- 9. WE CONFIRM THAT NECESSARY ARRANGEMENTS HAVE BEEN MADE TO ENSURE THAT THE MONEYS RECEIVED PURSUANT TO THE ISSUE ARE KEPT IN A SEPARATE BANK ACCOUNT AS PER THE PROVISIONS OF SUB-SECTION (3) OF SECTION 40 OF THE COMPANIES ACT, 2013 AND THAT SUCH MONEYS SHALL BE RELEASED BY THE SAID BANK ONLY AFTER PERMISSION IS OBTAINED FROM ALL THE STOCK EXCHANGES MENTIONED IN THE PROSPECTUS. WE FURTHER CONFIRM THAT THE AGREEMENT ENTERED INTO BETWEEN THE BANKERS TO THE ISSUE AND THE ISSUER SPECIFICALLY CONTAINS THIS CONDITION – NOTED FOR COMPLIANCE**
- 10. WE CERTIFY ALL THE SHARES SHALL BE ISSUED IN DEMATERIALIZED FORM IN COMPLIANCE WITH THE PROVISIONS OF SECTION 29 OF THE COMPANIES ACT, 2013 AND THE DEPOSITORIES ACT, 1996 AND THE REGULATIONS MADE THEREUNDER.**
- 11. WE CERTIFY THAT ALL THE APPLICABLE DISCLOSURES MANDATED IN THE SECURITIES AND EXCHANGE BOARD OF INDIA (ISSUE OF CAPITAL AND DISCLOSURE REQUIREMENTS) REGULATIONS, 2009 HAVE BEEN MADE IN ADDITION TO DISCLOSURES WHICH, IN OUR VIEW, ARE FAIR AND ADEQUATE TO ENABLE THE INVESTOR TO MAKE A WELL INFORMED DECISION.**
- 12. WE CERTIFY THAT THE FOLLOWING DISCLOSURES HAVE BEEN MADE IN THE PROSPECTUS:**
 - A. AN UNDERTAKING FROM THE ISSUER THAT AT ANY GIVEN TIME, THERE SHALL BE ONLY ONE DENOMINATION FOR THE EQUITY SHARES OF THE ISSUER AND**
 - B. AN UNDERTAKING FROM THE ISSUER THAT IT SHALL COMPLY WITH SUCH DISCLOSURE AND ACCOUNTING NORMS SPECIFIED BY THE BOARD FROM TIME TO TIME.**
- 13. WE UNDERTAKE TO COMPLY WITH THE REGULATIONS PERTAINING TO ADVERTISEMENT IN TERMS OF THE SECURITIES AND EXCHANGE BOARD OF INDIA (ISSUE OF CAPITAL AND DISCLOSURE REQUIREMENTS) REGULATIONS, 2009 WHILE MAKING THE ISSUE.**
- 14. WE ENCLOSE A NOTE EXPLAINING HOW THE PROCESS OF DUE DILIGENCE HAS BEEN EXERCISED BY US IN VIEW OF THE NATURE OF CURRENT BUSINESS BACKGROUND OR THE ISSUER, SITUATION AT WHICH THE PROPOSED BUSINESS STANDS, THE RISK FACTORS, PROMOTERS EXPERIENCE, ETC.**
- 15. WE ENCLOSE A CHECKLIST CONFIRMING REGULATION-WISE COMPLIANCE WITH THE APPLICABLE PROVISIONS OF THE SECURITIES AND EXCHANGE BOARD OF INDIA (ISSUE OF CAPITAL AND DISCLOSURE REQUIREMENTS) REGULATIONS, 2009, CONTAINING DETAILS SUCH AS THE REGULATION NUMBER, ITS TEXT, THE STATUS OF COMPLIANCE, PAGE NUMBER OF THE PROSPECTUS WHERE THE REGULATION HAS BEEN COMPLIED WITH AND OUR COMMENTS, IF ANY.**
- 16. WE ENCLOSE STATEMENT ON 'PRICE INFORMATION OF PAST ISSUES HANDLED BY MERCHANT BANKER BELOW (WHO ARE RESPONSIBLE FOR PRICING THIS ISSUE)', AS PER FORMAT SPECIFIED BY SEBI THROUGH CIRCULAR.**
- 17. WE CERTIFY THAT PROFITS FROM RELATED PARTY TRANSACTIONS HAVE ARISEN FROM LEGITIMATE BUSINESS TRANSACTIONS.**

ADDITIONAL CONFIRMATIONS/ CERTIFICATION TO BE GIVEN BY MERCHANT BANKER IN DUE DILIGENCE CERTIFICATE TO BE GIVEN ALONG WITH OFFER DOCUMENT REGARDING SME EXCHANGE

1. WE CONFIRM THAT NONE OF THE INTERMEDIARIES NAMED IN THE PROSPECTUS HAVE BEEN DEBARRED FROM FUNCTIONING BY ANY REGULATORY AUTHORITY.
2. WE CONFIRM THAT ALL THE MATERIAL DISCLOSURES IN RESPECT OF THE ISSUER HAVE BEEN MADE IN PROSPECTUS AND CERTIFY THAT ANY MATERIAL DEVELOPMENT IN THE ISSUER OR RELATING TO THE ISSUE UP TO THE COMMENCEMENT OF LISTING AND TRADING OF THE SPECIFIED SECURITIES OFFERED THROUGH THIS ISSUE SHALL BE INFORMED THROUGH PUBLIC NOTICES/ ADVERTISEMENTS IN ALL THOSE NEWSPAPERS IN WHICH PRE-ISSUE ADVERTISEMENT AND ADVERTISEMENT FOR OPENING OR CLOSURE OF THE ISSUE HAVE BEEN GIVEN.
3. WE CONFIRM THAT THE ABRIDGED PROSPECTUS CONTAINS ALL THE DISCLOSURES AS SPECIFIED IN THE SECURITIES AND EXCHANGE BOARD OF INDIA (ISSUE OF CAPITAL AND DISCLOSURE REQUIREMENTS) REGULATIONS, 2009.
4. WE CONFIRM THAT AGREEMENTS HAVE BEEN ENTERED INTO WITH THE DEPOSITORIES FOR DEMATERIALISATION OF THE SPECIFIED SECURITIES OF THE ISSUER.
5. WE CERTIFY THAT AS PER THE REQUIREMENTS OF FIRST PROVISIO TO SUB-REGULATION (4) OF REGULATION 32 OF SECURITIES AND EXCHANGE BOARD OF INDIA (ISSUE OF CAPITAL AND DISCLOSURE REQUIREMENTS) REGULATIONS, 2009; CASH FLOW STATEMENT HAS BEEN PREPARED AND DISCLOSED IN THE PROSPECTUS. - **NOT APPLICABLE**
6. WE CONFIRM THAT UNDERWRITING AND MARKET MAKING ARRANGEMENTS AS PER REQUIREMENTS OF REGULATION 106P AND 106V OF THE SECURITIES AND EXCHANGE BOARD OF INDIA (ISSUE OF CAPITAL AND DISCLOSURE REQUIREMENTS) REGULATIONS, 2009 HAVE BEEN MADE.

The filing of this Prospectus does not, however, absolve our company from any liabilities under section 34 and section 36 of the Companies Act, 2013 or from the requirement of obtaining such statutory and / or other clearances as may be required for the purpose of the proposed Issue. SEBI further reserves the right to take up at any point of time, with the LM any irregularities or lapses in the Prospectus.

All legal requirements pertaining to the Issue will be complied with at the time of registration of the Prospectus with the Registrar of Companies, Mumbai in terms of sections 26 and 33(1) of the Companies Act, 2013.

Statement on Price Information of Past Issues handled by Hem Securities Limited:

Sr. No.	Issuer Name	Issue size (₹ in cr.)	Issue price (₹)	Listing Date	Opening price on listing day (₹)	Closing price on listing day (₹)	% Change in Price on listing day (Closing) vs. Issue Price	Benchmark index on listing day (Closing)	Closing price as on 10th calendar day from listing day (₹)	Benchmark index as on 10th calendar days from listing day (Closing)	Closing price as on 20th calendar day from listing day (₹)	Benchmark index as on 20th calendar days from listing day (Closing)	Closing price as on 30th calendar day from listing day (₹)	Benchmark index as on 30th calendar days from listing day (Closing)
1.	Shekhawati Poly-Yarn Ltd.	36.00	30.00	12.1.11	32.50	47.50	58.33	19,534.10	24.00	19,151.28	25.45	18,022.22	24.30	17,728.61
2.	Tijaria Polypipes Ltd.	60.00	60.00	14.10.11	62.00	18.10	(69.83)	17,082.69	15.05	16,939.28	11.97	17,481.93	16.28	17,118.74

Bansal Roofing Products Limited

3.	Samruddhi Realty Ltd.	2.60	12.00	12.04.13	13.00	13.65	13.75	18,242.56	17.25	19,169.83	22.60	19,735.77	22.90	19,691.67
4.	Captain Polyplast Ltd.	5.94	30.00	11.12.13	33.00	34.65	15.50	21,171.41	36.00	21,101.03	35.00	21,170.68	41.50	20,758.49
5.	Tentiwal Wire Products Ltd.	2.12	13.00	31.12.13	12.50	11.90	(8.46)	21,170.68	10.75	20,758.49	11.50	21,205.05	10.30	20,498.25
6.	R&B Denims Ltd	3.71	10.00	22.04.14	10.55	11.05	10.05	22,758.37	14.70	22,403.89	11.10	23,551.00	12.00	24,374.40
Financial Year	Total no. of IPOs	Total Funds raised (₹ in cr.)	Nos. of IPOs trading at discount on listing day			Nos. of IPOs trading at premium on listing day			Nos. of IPOs trading at discount as on 30th calendar day from listing day			Nos. of IPOs trading at premium as on 30th calendar day from listing day		
			Over 50%	Between 25-50%	Less than 25%	Over 50%	Between 25-50%	Less than 25%	Over 50%	Between 25-50%	Less than 25%	Over 50%	Between 25-50%	Less than 25%
2014-15	1	3.71	-	-	-	-	-	1	-	-	-	-	-	1
2013-14	3	10.66	-	-	1	-	-	2	-	-	1	1	1	-
2012-13	-	-	-	-	-	-	-	-	-	-	-	-	-	-
2011-12	1	60.00	1	-	-	-	-	-	1	-	-	-	-	-
2010-11	1	36.00	-	-	-	1	-	-	-	-	1	-	-	-
2009-10	-	-	-	-	-	-	-	-	-	-	-	-	-	-

Note:

- In case the 10th, 20th and 30th calendar day from the date of listing is a holiday, the share price and benchmark index is taken for the immediately following working day.
- BSE SENSEX has been considered as the benchmark index.

Track Record of past issues handled by Hem Securities Limited

For details regarding track record of LM to the Issue as specified in the Circular reference no. CIR/MIRSD/1/2012 dated January 10, 2012 issued by the SEBI, please refer the website of the LM at: www.hemonline.com

Disclaimer from our Company, Directors and the LM

Our Company, our Directors and the LM accept no responsibility for statements made otherwise than in this Prospectus or in the advertisement or any other material issued by or at our Company's instance and that anyone placing reliance on any other source of information, including our Company's website www.bansalroofing.com would be doing so at his or her own risk.

The LM accept no responsibility, save to the limited extent as provided in (i) the MOU entered between the LM and our Company on April 5, 2014; (ii) the Underwriting Agreement dated April 5, 2014 entered into between the Underwriters and our Company; and (iii) the Market Making Agreement dated April 5, 2014 entered into among the Market Maker, LM and our Company.

All information shall be made available by our Company and the LM to the public and investors at large and no selective or additional information would be available for a section of the investors in any manner whatsoever including at road show presentations, in research or sales reports, at bidding centres or elsewhere.

The LM and their respective associates and affiliates may engage in transactions with, and perform services for, our Company, our Promoter Group, Group Entities, or our affiliates or associates in the ordinary course of business and have engaged, or may in future engage, in commercial banking and investment banking transactions with our Company, our Promoter Group, Group Entities, and our affiliates or associates, for which they have received and may in future receive compensation.

Caution

The Applicants making application in the Issue will be required to confirm and will be deemed to have represented to our Company, the Underwriters and their respective directors, officers, agents, affiliates and representatives that they are eligible under all applicable laws, rules, regulations, guidelines and approvals to acquire Equity Shares and will not offer, sell, pledge or transfer the Equity Shares of our Company to any person who is not eligible under applicable laws, rules, regulations, guidelines and approvals to acquire the Equity Shares. Our Company, the Underwriters and their respective directors, officers, agents, affiliates and representatives accept no responsibility or liability for advising any investor on whether such investor is eligible to acquire the Equity Shares in the Issue.

Disclaimer in Respect of Jurisdiction

This Issue is being made in India to persons resident in India (including Indian nationals resident in India who are majors, HUFs, companies, corporate bodies and societies registered under applicable laws in India and authorized to invest in shares, Indian mutual funds registered with SEBI, Indian financial institutions, commercial banks, regional rural banks, cooperative banks (subject to RBI permission), or trusts under applicable trust law and who are authorized under their constitution to hold and invest in shares, public financial institutions as specified in Section 2(72) of the Companies Act, 2013, VCFs, state industrial development corporations, insurance companies registered with the Insurance Regulatory and Development Authority, provident funds (subject to applicable law) with a minimum corpus of ₹ 2,500.00 Lakhs and pension funds with a minimum corpus of ₹ 2,500.00 Lakhs, and permitted non-residents including FIIs, Eligible NRIs, multilateral and bilateral development financial institutions, FVCIs and eligible foreign investors, insurance funds set up and managed by army, navy or air force of the Union of India and insurance funds set up and managed by the Department of Posts, India provided that they are eligible under all applicable laws and regulations to hold Equity Shares of our Company. This Prospectus does not, however, constitute an offer to sell or an invitation to subscribe for Equity Shares offered hereby in any jurisdiction other than India to any person to whom it is unlawful to make an offer or invitation in such jurisdiction. Any person into whose possession this Prospectus comes is required to inform himself or herself about, and to observe, any such restrictions.

Any dispute arising out of this Issue will be subject to jurisdiction of the competent court(s) in Vadodara, Gujarat, India.

No action has been, or will be, taken to permit a public offering in any jurisdiction where action would be required for that purpose. Accordingly, the Equity Shares represented hereby may not be offered or sold, directly or indirectly, and this Prospectus may not be distributed in any jurisdiction, except in accordance with the legal requirements applicable in such jurisdiction. Neither the delivery of this Prospectus nor any sale hereunder shall, under any circumstances, create any implication that there has been no change in the affairs of our Company from the date hereof or that the information contained herein is correct as of any time subsequent to this date.

Disclaimer Clause of the SME Platform of BSE

The BSE by way of its letter dated June 6, 2014 has granted its permission to our Company to use its name in this Prospectus as one of the stock exchanges on which our Company's securities are proposed to be listed on the SME Platform of BSE. BSE has scrutinized this Prospectus for its limited internal purpose of deciding on the matter for granting the aforesaid permission to our Company. BSE does not in any manner:

- i. Warrant, certify or endorse the correctness or completeness of any of the contents of this offer document; or
- ii. Warrant that this Company's securities will be listed or will continue to be listed on BSE; or
- iii. Take any responsibility for the financial or other soundness of this Company, its Promoters, its management or any scheme or project of this Company;

And it should not for any reason be deemed or construed that this Prospectus has been cleared or approved by the BSE. Every person who desires to apply for or otherwise acquires any securities in this Company may do so pursuant to independent inquiry, investigations and analysis and shall not have any claim against BSE whatsoever by reason of loss which may be suffered by such person consequent to or in connection with such subscription/acquisition whether by reason of anything stated or omitted to be stated herein or for any other reason whatsoever.

Disclaimer Clause under Rule 144a of the U.S. Securities Act

The Equity Shares have not been, and will not be, registered under the U.S. Securities Act 1933, as amended (the "Securities Act") or any state securities laws in the United States and may not be offered or sold within the United States or to, or for the account or benefit of, "U.S. persons" (as defined in Regulation S under the Securities Act), except pursuant to

Bansal Roofing Products Limited

an exemption from, or in a transaction not subject to, the registration requirements of the Securities Act. Accordingly, the Equity Shares will be offered and sold only outside the United States in compliance with Regulation S of the Securities Act and the applicable laws of the jurisdiction where those offers and sales occur. The Equity Shares have not been, and will not be, registered, listed or otherwise qualified in any other jurisdiction outside India and may not be offered or sold, and Bids may not be made by persons in any such jurisdiction, except in compliance with the applicable laws of such jurisdiction.

Further, each Applicant where required agrees that such Applicant will not sell or transfer any Equity Shares or create any economic interest therein, including any off-shore derivative instruments, such as participatory notes, issued against the Equity Shares or any similar security, other than pursuant to an exemption from, or in a transaction not subject to, the registration requirements of the Securities Act and in compliance with applicable laws and legislations in each jurisdiction, including India.

Filing

The Prospectus is being filed with BSE SME Platform, 25th Floor, P. J. Towers, Dalal Street, Fort, Mumbai – 400 001.

A copy of this Prospectus will not be filed with the SEBI nor will SEBI issue any observation on the offer document in term of Regulation 106(M)(3) of the SEBI (ICDR) Regulations. However, a copy of the Prospectus shall be filed with SEBI at the Securities and Exchange Board of India, Western Regional Office, Unit No: 002, Ground Floor, SAKAR I, Near Gandhigram Railway Station, Opposite Nehru Bridge, Ashram Road, Ahmedabad - 380 009, Gujarat, India.

A copy of the Prospectus, along with the other documents required to be filed under Section 32 of the Companies Act, 2013 will be delivered to the Registrar of Companies, Gujarat, Dadra and Nagar Havelli situated at Roc Bhavan, Opposite Rupal Park Society, Behind Ankur Bus Stop, Naranpura, Ahmedabad – 380013, India.

Listing

In terms of Chapter XB of the SEBI (ICDR) Regulations there is no requirement of obtaining in- principle approval of the SME Platform of BSE. However, application shall be made to SME Platform of BSE for obtaining permission for listing of the Equity Shares being offered and sold in the Issue on its SME Platform after the allotment in the Issue.

BSE is the SME Exchange, with which the Basis of Allotment will be finalized for the Issue. If the permission to deal in and for an official quotation of the Equity Shares on the SME Platform is not granted by BSE, our Company shall forthwith repay, without interest, all moneys received from the applicants in pursuance of the Prospectus. If such money is not repaid within eight (8) Days from the date our Company becomes liable to repay it, then our Company and every officer in default shall, on and from expiry of eight (8) Days, be liable to repay such application money, with interest at the rate as prescribed under the Companies Act.

Our Company has obtained approval from BSE by way of its letter dated June 6, 2014 to use the name of BSE in this Prospectus for listing of equity shares on SME Platform of BSE.

Our Company shall ensure that all steps for the completion of the necessary formalities for listing and commencement of trading at the SME Platform of BSE are taken within twelve (12) Working Days of the Issue Closing Date.

Impersonation

Attention of the Applicants is specifically drawn to the provisions of sub-section (1) of Section 38 of the Companies Act, 2013 which is reproduced below:

“38. (1) Any person who-

- (a) makes or abets making of an application in a fictitious name to a company for acquiring, or subscribing for, its securities; or
- (b) makes or abets making of multiple applications to a company in different names or in different combinations of his name or surname for acquiring or subscribing for its securities; or
- (c) otherwise induces directly or indirectly a company to allot, or register any transfer of, securities to him, or to any other person in a fictitious name,

shall be liable for action under section 447.

Consents

Consents in writing of the Directors, the Promoters, the Company Secretary & Compliance Officer, Accounts & Administration – Head Manager, the Statutory Auditor, the Peer Review Auditor, the Banker(s) to the Company; the Lead Manager, Registrar to the Issue, Banker(s) to the Issue, Legal Advisor to the Issue, Underwriter(s) to the Issue and Market Maker to the Issue to act in their respective capacities, will be obtained and filed along with a copy of the Prospectus with the RoC, as required under Sections 26 of the Companies Act, 2013 and such consents will not be withdrawn up to the time of delivery of the Prospectus for registration with the RoC.

In accordance with the Companies Act and the SEBI (ICDR) Regulations, M/s. Santlal Patel & Co., Chartered Accountants, Statutory Auditor, M/s. V. J. Amin & Co., Chartered Accountants, Peer Review Auditors of the Company have agreed to provide their written consent to the inclusion of their respective reports on Statement of Possible Tax Benefits relating to the possible tax benefits and restated financial statements as included in this Draft Prospectus/Prospectus in the form and context in which they appear therein and such consent and reports will not be withdrawn up to the time of delivery of the Prospectus.

Experts Opinion

Except for the reports in the section “*Financial Information of our Company*” and “*Statement of Tax Benefits*” on page 113 and page 57 of this Prospectus from the Peer Review Auditors and Statutory Auditor respectively, our Company has not obtained any expert opinions. However, the term “expert” shall not be construed to mean an “expert” as defined under the U.S. Securities Act 1933.

Expenses of the Issue

The total expenses of the Issue are estimated to be approximately ₹ 40.00 Lakhs, which is 19.61% of the Issue size. The expenses of this Issue include, among others, underwriting and management fees, Market Making Fees, selling commissions, SCSB’s commission/ fees, printing and distribution expenses, legal fees, statutory advertisement expenses, registrar and depository fees and listing fees.

No.	Particulars	Amount (₹ in Lakhs)	Percentage of Total Estimated Issue Expenditure (%)	Percentage of Issue Size (%)
1.	Payment to Merchant Banker including, underwriting and selling commissions, brokerages, payment to other intermediaries such as Legal Advisors, Registrars, Bankers etc and other out of pocket expenses	32.00	80.00	15.69
2.	Printing and Stationery and postage expenses	3.00	7.50	1.47
3.	Advertising and Marketing expenses	2.00	5.00	0.98
4.	Regulatory fees and expenses	3.00	7.50	1.47
	Total estimated Issue Expenses	40.00	100.00	19.61

Fees, Brokerage and Selling Commission payable to the LM

The total fees payable to the Lead Manager will be as per the (i) Memorandum of Understanding dated April 5, 2014 with the Lead Manager Hem Securities Limited, (ii) the Underwriting Agreement dated April 5, 2014 with Underwriter Hem Securities Limited and (iii) the Market Making Agreement dated April 5, 2014 with Market Maker Hem Securities Limited, a copy of which is available for inspection at our Registered Office from 10.00 am to 5.00 pm on Working Days from the date of the Prospectus until the Issue Closing Date.

Fees Payable to the Registrar to the Issue

The fees payable to the Registrar to the Issue for processing of applications, data entry, printing of refund orders, preparation of refund data on magnetic tape and printing of bulk mailing register will be as per the agreement between our Company and the Registrar to the Issue dated March 24, 2014, a copy of which is available for inspection at our Company’s Registered Office.

Bansal Roofing Products Limited

The Registrar to the Issue will be reimbursed for all out-of-pocket expenses including cost of stationery, postage, stamp duty, and communication expenses. Adequate funds will be provided to the Registrar to the Issue to enable it to make refunds in any of the modes described in this Prospectus or send allotment advice by registered post/speed post.

Particulars regarding Public or Rights Issues during the last five (5) years

Our Company has not made any previous public or rights issue in the five (5) years preceding the date of this Prospectus.

Previous issues of Equity Shares otherwise than for cash

Our Company has not made any previous issues of shares for consideration other than cash. For further details please refer to section titled "*Capital Structure*" beginning on page 39 of this Prospectus.

Underwriting Commission, brokerage and selling commission on Previous Issues

Since this is the initial public offering of our Company's Equity Shares, no sum has been paid or has been payable as commission or brokerage for subscribing for or procuring or agreeing to procure subscription for any of the Equity Shares since our Company's incorporation.

Previous issues by companies under the same Management

No company under the same management within the meaning of Section 370(1B) of the Companies Act has made any public issue or rights issue during the last three (3) years.

Performance vis-a-vis objects - Last Three Issues

There has not been any previous public issue of our Equity Shares.

Performance vis-a-vis objects - Last Issue of Group/Associate Companies

All of our Group / Associate Companies are unlisted and have not made a public issue of shares.

Outstanding Debentures or Bond Issues or Redeemable Preference Shares

Our Company does not have any outstanding debentures or bonds or Preference Redeemable Shares as on the date of filing this Prospectus.

Outstanding Convertible Instruments

Our Company does not have any outstanding convertible instruments as on the date of filing this Prospectus.

Option to Subscribe

Equity Shares being offered through the Prospectus can be applied for in dematerialized form only.

Stock Market Data of the Equity Shares

This being an initial public offering of the Equity Shares of our Company, the Equity Shares are not listed on any Stock Exchanges.

Mechanism for Redressal of Investor Grievances

The Agreement amongst the Registrar to the Issue, our Company provides for retention of records with the Registrar to the Issue for a period of at least three (3) year from the last date of dispatch of the letters of allotment, or refund orders, demat credit or where refunds are being made electronically, giving of refund instructions to the clearing system, to enable the investors to approach the Registrar to the Issue for redressal of their grievances.

All grievances relating to the Issue may be addressed to the Registrar to the Issue, giving full details such as name, address of the applicant, application number, number of Equity Shares applied for, amount paid on application, Depository Participant, and the bank branch or collection centre where the application was submitted.

All grievances relating to the ASBA process may be addressed to the SCSBs, giving full details such as name, address of the applicant, number of Equity Shares applied for, amount paid on application and the relevant Designated Branch or the collection centre of the SCSBs where the Application Form was submitted by the ASBA Applicants.

Disposal of Investor Grievances by our Company

Our Company estimates that the average time required by our Company or the Registrar to the Issue for the redressal of routine investor grievances shall be fifteen (15) Working Days from the date of receipt of the complaint. In case of complaints that are not routine or where external agencies are involved, our Company will seek to redress these complaints as expeditiously as possible.

Our Company has constituted Shareholder's and Investors Grievance Committee in the meeting of our Board of Directors held on January 23, 2104. For further details on the Shareholder's and Investor's Grievance Committee, please refer to section titled "**Our Management**" beginning on page 93 of this Prospectus.

Our Company has appointed Ms. Harneetkaur S. Anand, Company Secretary, as the Compliance Officer to redress complaints, if any, of the investors participating in the Issue. Contact details for our Company Secretary and Compliance Officer are as follows:

Ms. Harneetkaur S. Anand

Bansal Roofing Products Limited
3/2, Labdhi Industrial Estate, Acid Mill Compound,
Ranmukteshwar Road, Pratapnagar,
Vadodara – 390004, Gujarat, India
Tel. No. +91-265-2580178
Fax No. +91-265-2581365
E-mail: cs@bansalroofing.com
Website: www.bansalroofing.com

Investors can contact the Compliance Officer or the Registrar in case of any pre-Issue or post-Issue related problems such as non-receipt of letters of allocation, credit of allotted Equity Shares in the respective beneficiary account or refund orders, etc.

Pursuant to the press release no. PR. No. 85/2011 dated June 8, 2011, SEBI has launched a centralized web based complaints redress system "SCORES". This would enable investors to lodge and follow up their complaints and track the status of redressal of such complaints from anywhere. For more details, investors are requested to visit the website www.scores.gov.in.

Status of Investor Complaints

We confirm that we have not received any investor complaint during the three years preceding the date of this Prospectus and hence there are no pending investor complaints as on the date of this Prospectus.

Disposal of investor grievances by listed companies under the same management as our Company

We do not have any other listed company under the same management.

Change in Auditors during the last three (3) years

Except for appointment of M/s. V.J. Amin & Associates, Chartered Accountants, as peer review auditor in addition to the existing auditors, there have been no changes in our Company's auditors in the last three (3) years.

Capitalization of Reserves or Profits

Except with respect to the bonus shares as disclosed under section titled "**Capital Structure**" beginning on page **Error! Bookmark not defined.** of this Prospectus, our Company has not capitalized its reserves or profits at any time during the last five (5) years.

Revaluation of Assets

Our Company has not revalued its assets in five (5) years preceding the date of this Prospectus.

Tax Implications

Investors who are allotted Equity Shares in the Issue will be subject to capital gains tax on any resale of the Equity Shares at applicable rates, depending on the duration for which the investors have held the Equity Shares prior to such resale and whether the Equity Shares are sold on the Stock Exchanges. For details, please refer the section titled "*Statement of Tax Benefits*" beginning on page 57 of this Prospectus.

Purchase of Property

Other than as disclosed in "*Our Business*" Section on page 72 of the Prospectus, there is no property which has been purchased or acquired or is proposed to be purchased or acquired which is to be paid for wholly or partly from the proceeds of the present Issue or the purchase or acquisition of which has not been completed on the date of the Prospectus, other than property, in respect of which:

The contract for the purchase or acquisition was entered into in the ordinary course of business, or the contract was entered into in contemplation of the Issue, or that the Issue was contemplated in consequence of the contract; or the amount of the purchase money is not material.

Except as stated elsewhere in the Prospectus, our Company has not purchased any property in which the Promoter and/or Directors have any direct or indirect interest in any payment made there under.

Servicing Behavior

There has been no default in payment of statutory dues or of interest or principal in respect of our borrowings or deposits.

Payment or benefit to officers of Our Company

Except statutory benefits upon termination of their employment in our Company or superannuation, no officer of our Company is entitled to any benefit upon termination of his employment in our Company or superannuation.

Except as disclosed in chapter titled "*Related Party Transactions*" beginning on page 134 of the Prospectus, none of the beneficiaries of loans and advances and sundry debtors are related to the Directors of our Company.

SECTION VII: ISSUE RELATED INFORMATION

TERMS OF THE ISSUE

The Equity Shares being issued are subject to the provisions of the Companies Act, SCRR, SEBI (ICDR) Regulations, 2009, our Memorandum and Articles of Association, the terms of the Prospectus, the Prospectus, Application Form, CAN, the Revision Form, Allotment advices, the SME listing agreement and other terms and conditions as may be incorporated in the documents/certificates that may be executed in respect of the Issue. The Equity Shares shall also be subject to all applicable laws, guidelines, rules, notifications and regulations relating to the issue of capital and listing and trading of securities issued from time to time by SEBI, the GoI, the Stock Exchanges, the RoC, the FIPB, the RBI and/or other authorities, as in force on the date of the Issue and to the extent applicable.

Ranking of Equity Shares

The Equity Shares being offered/ issued shall be subject to the provisions of the Companies Act and our Memorandum and Articles of Association and shall rank *pari passu* in all respects with the existing Equity Shares of our Company including rights in respect of dividend. The allottees will be entitled to dividend or any other corporate benefits, if any, declared by our Company after the Date of Allotment. Please refer to section titled "**Main Provisions of Articles of Association**" beginning on page 201 of this Prospectus.

Mode of Payment of Dividend

Our Company shall pay dividend to the shareholders of our Company in accordance with the provisions of the Companies Act, Articles of Association of our Company and provisions of the SME Listing Agreement.

Face Value and Issue Price

The Equity Shares with a face value of ₹ 10.00 each are being issued in terms of the Prospectus at an Issue price of ₹30.00 per Equity Share (including a premium of ₹ 20.00 per Equity Share) which has been determined by our Company in consultation with the LM and is justified under the section titled "**Basis for Issue Price**" beginning on page 55 of this Prospectus. At any given point of time, there shall be only one denomination for the Equity Shares of our Company, subject to applicable laws.

Rights of the Equity Shareholders

Subject to applicable laws, the equity shareholders shall have the following rights:

1. Right to receive dividend, if declared;
2. Right to attend general meetings and exercise voting powers, unless prohibited by law;
3. Right to vote on a poll either in person or by proxy;
4. Right to receive offers for rights shares and be allotted bonus shares, if announced;
5. Right to receive surplus on liquidation subject to any statutory and other preferential claims being satisfied;
6. Right of free transferability, subject to applicable law, including any RBI Rules and Regulations; and
7. Such other rights, as may be available to a shareholder of a listed public company under the Companies Act, the terms of SME listing agreement executed with the Stock Exchanges and the Memorandum and Articles of Association of our Company.

For further details on the main provisions of our Company's Articles of Association dealing with voting rights, dividend, forfeiture and lien, transfer and transmission and/or consolidation/splitting, please refer section titled "**Main Provisions of Articles of Association**" beginning on page 201 of this Prospectus.

Minimum Application Value, Market Lot and Trading Lot

In terms of the provision of the Depositories Act, 1996 (22 of 1996) & the regulations made under and Section 29 of the Companies Act, 2013 the Equity Shares of our Company shall be allotted only in dematerialized form i.e. not in the form of physical certificates but be fungible and be represented by the statement issued through electronic mode. Hence, the Equity Shares being offered can be applied for in the dematerialised form only.

The Equity Shares, as per the provisions of the SEBI (ICDR) Regulations, shall be allotted only in dematerialised form and

Bansal Roofing Products Limited

trading shall only be in dematerialised form.

The trading of the Equity Shares will happen in the minimum contract size of 4,000 Equity Shares and the same may be modified by the SME Platform of BSE from time to time by giving prior notice to investors at large.

Allocation and allotment of Equity Shares through this Prospectus will be done in multiples of 4,000 Equity Shares subject to a minimum allotment of 4,000 Equity Shares to the successful Applicants.

Joint Holders

Where 2 (two) or more persons are registered as the holders of the Equity Shares, they shall be entitled to hold the same as joint tenants with benefits of survivorship.

Nomination Facility to Investors

In accordance with Section 72 of the Companies Act, 2013 the sole or first Applicant, along with other joint Applicants, may nominate any one person in whom, in the event of the death of sole Applicant or in case of joint Applicants, death of all the Applicants, as the case may be, the Equity Shares allotted, if any, shall vest. A person, being a nominee, entitled to the Equity Shares by reason of the death of the original holder(s), shall in accordance with Section 72 of the Companies Act, 2013 be entitled to the same advantages to which he or she would be entitled if he or she were the registered holder of the Equity Share(s). Where the nominee is a minor, the holder(s) may make a nomination to appoint, in the prescribed manner, any person to become entitled to Equity Share(s) in the event of his or her death during the minority. A nomination shall stand rescinded upon a sale of equity share(s) by the person nominating. A buyer will be entitled to make a fresh nomination in the manner prescribed. Fresh nomination can be made only on the prescribed form available on request at the Registered Office or to the Registrar and Transfer Agents of our Company.

In accordance with Section 72 of the Companies Act, 2013 any Person who becomes a nominee by virtue of this section shall upon the production of such evidence as may be required by the Board, elect either:

1. To register himself or herself as the holder of the Equity Shares; or
2. To make such transfer of the Equity Shares, as the deceased holder could have made.

Further, the Board may at any time give notice requiring any nominee to choose either to be registered himself or herself or to transfer the Equity Shares, and if the notice is not complied with within a period of ninety (90) days, the Board may thereafter withhold payment of all dividends, bonuses or other moneys payable in respect of the Equity Shares, until the requirements of the notice have been complied with.

Since the Allotment of Equity Shares in the Issue will be made only in dematerialised form, there is no need to make a separate nomination with our Company. Nominations registered with respective depository participant of the Applicant would prevail. If the Applicants require changing their nomination, they are requested to inform their respective depository participant.

Period of operation of Subscription list of public issue

ISSUE OPENS ON	THURSDAY, JUNE 26, 2014
ISSUE CLOSES ON	MONDAY, JUNE 30, 2014

Minimum Subscription

In accordance with Regulation [106P](1) of SEBI ICDR Regulations, this Issue is 100% underwritten. Also, in accordance with explanation to Regulation [106P](1) of SEBI ICDR Regulations, the underwriting shall not be restricted up to the minimum subscription level.

If our Company does not receive the subscription of 100% of the Issue including devolvement of Underwriters within 60 (sixty) days from the date of closure of the issue, our Company shall forthwith refund the entire subscription amount received. If there is a delay beyond 8 (eight) days after our Company becomes liable to pay the amount, our Company shall pay interest prescribed under the provisions of Companies Act, 2013.

Further, In accordance with Regulation [106R] of SEBI ICDR Regulations, No allotment shall be made pursuant to the Issue, if the number of prospective allottees is less than 50 (fifty).

Arrangements for disposal of odd lots

The trading of the Equity Shares will happen in the minimum contract size of 4,000 equity shares. However, the Market Maker shall buy the entire shareholding of a shareholder in one lot, where value of such shareholding is less than ₹1,00,000.00 i.e. the minimum contract size allowed for trading on the SME Exchange.

Restrictions on transfer and transmission of shares or debentures and on their consolidation or splitting

Except for lock-in of the pre-Issue Equity Shares and Promoter, minimum contribution in the Issue as detailed in the section titled "**Capital Structure**" beginning on page 39 of this Prospectus, and except as provided in the Articles of Association of our Company, there are no restrictions on transfers of Equity Shares. There are no restrictions on transfer, transmission of shares/ debentures and on their consolidation/ splitting except as provided in the Articles of Association. For further details, please refer to the section titled "**Main Provisions of the Articles of Association**" beginning on page 201 of this Prospectus.

Option to receive securities in Dematerialised Form

Investors should note that allotment of Equity Shares to all successful Applicants will only be in the dematerialised form. Applicants will not have the option of getting allotment of the Equity Shares in physical form. The Equity Shares on allotment shall be traded only in the dematerialised segment of the SME Stock Exchange.

New financial instruments

There are no new financial instruments such as deep discounted bonds, debentures, warrants, secured premium notes, etc. issued by our Company.

Migration to Main Board

Our Company may migrate to the main board of BSE from the SME Exchange on a later date subject to the following:

- If the Paid-up Capital of our Company is likely to increase above ₹25 Crores by virtue of any further issue of capital by way of rights, preferential issue, bonus issue etc. (which has been approved by a special resolution through postal ballot wherein the votes cast by the shareholders other than the promoters in favour of the proposal amount to at least two times the number of votes cast by shareholders other than promoter shareholders against the proposal and for which our Company has obtained in-principal approval from the main board), we shall have to apply to BSE for listing our shares on its Main Board subject to the fulfilment of the eligibility criteria for listing of specified securities laid down by the Main Board.
- If our Company satisfy the eligibility criteria as specified in Regulation 26(1) of SEBI (ICDR) Regulations either at the time of initial listing on SME platform or at the time of seeking migration to Main Board. However, same will not be applicable where our Company had sought listing on SME platform by following the process and requirements prescribed in Regulation 26(2)(a) of SEBI (ICDR) Regulations.

Market Making

The Equity Shares offered through this Issue are proposed to be listed on the SME Exchange, wherein the LM to this Issue shall ensure compulsory Market Making through the registered Market Makers of the SME Exchange for a minimum period of three (3) years from the date of listing on the SME Exchange. For further details of the agreement entered into between our Company, the LM and the Market Maker please refer to section titled "**General Information - Details of the Market Making Arrangements for this Issue**" beginning on page 37 of this Prospectus.

In accordance with the SEBI Circular No. CIR/MRD/DSA/31/2012 dated November 27, 2012, it has been decided to make applicable limits on the upper side for the Market Makers during market making process taking into consideration the Issue size in the following manner:

Issue size	Buy quote exemption threshold (including mandatory initial inventory of 5% of issue size)	Re-entry threshold for buy quotes (including mandatory initial inventory of 5% of issue size)
Upto ₹ 20 Crore, as applicable in our case	25%	24%

Further, the Market Maker shall give two (2) way quotes till it reaches the upper limit threshold, thereafter it has the option to give only sell quotes. Two (2) way quotes shall be resumed the moment inventory reaches the prescribed re-entry threshold.

In view of the Market Maker obligation, there shall be no exemption/threshold on downside. However, in the event the Market Maker exhausts its inventory through market making process on the SME Exchange, the concerned stock exchange may intimate the same to SEBI after due verification.

Pre-Issue Advertisement

Subject to Section 30 of the Companies Act, 2013 our Company shall, after registering the Prospectus with the RoC publish a pre-Issue advertisement, in the form prescribed by the SEBI (ICDR) Regulations, in one widely circulated English language national daily newspaper; one widely circulated Hindi language national daily newspaper and one regional newspaper with wide circulation where the Registered Office of our Company is situated.

ISSUE STRUCTURE

This Issue is being made in terms of Regulation 106(M)(1) of Chapter XB of SEBI (ICDR) Regulations, 2009, as amended from time to time, whereby, an issuer whose post issue paid up capital does not exceed ₹ 10 Crores, shall issue shares to the public and propose to list the same on the Small and Medium Enterprise Exchange ("**SME Exchange**", in this case being the SME Platform of BSE). For further details regarding the salient features and terms of such an issue please refer to section titled "**Terms of the Issue**" and "**Issue Procedure**" beginning on page 174 and 180 of this Prospectus.

The Issue is being made by way of Fixed Price method.

Particulars of the Issue	Net Issue to Public*	Market Maker Reservation Portion
Number of Equity Shares available for allocation	6,44,000 Equity Shares	36,000
Percentage of Issue Size available for allocation	94.71% of the Issue Size (50% to Retail Individual Investors and the balance 50% to Other than Retail Individual Investors).	5.29% of the Issue Size Firm allotment
Basis of Allotment	Proportionate subject to minimum allotment of 4,000 Equity Shares and further allotment in multiples of 4,000 Equity Shares each. For further details please refer to section titled " Issue Procedure -Basis of Allotment " beginning on page 193 of this Prospectus.	Firm Allotment
Mode of Application	For Other than Retail Individual Investors Applicants the application must be made compulsorily through the ASBA Process. The Retail Individual Applicant may apply through the ASBA or the Physical Form.	Through ASBA Process Only
Minimum Application Size	<u>For Other than Retail Individual Investors:</u> Such number of Equity Shares in multiples of 4,000 Equity Shares such that the Application Value exceeds ₹ 2,00,000 <u>For Retail Individual Investors:</u> 4,000 Equity Shares	36,000 Equity Shares
Maximum Application Size	<u>For Other than Retail Individual Investors:</u> The maximum application size is the Net Issue to public subject to limits the investor has to adhere under the relevant laws and regulations as applicable. <u>For Retail Individual Investors:</u> Such number of Equity Shares in multiples of 4,000 Equity Shares such that the Application Value does not exceed ₹ 2,00,000.	36,000 Equity Shares
Mode of Allotment	Compulsorily in dematerialized form	Compulsorily in dematerialized form
Trading Lot	4,000 Equity Shares	4,000 Equity Shares, However the

Bansal Roofing Products Limited

Particulars of the Issue	Net Issue to Public*	Market Maker Reservation Portion
		Market Makers may accept odd lots if any in the market as required under the SEBI (ICDR) Regulations.
Terms of Payment	The entire Application Amount will be payable at the time of submission of the Application Form.	

This Issue is being made in terms of Chapter XB of the SEBI (ICDR) Regulations, 2009, as amended from time to time. For further details please refer to ***“Terms of the Issue”*** on page 174 of this Prospectus.

*As per Regulation 43(4) of the SEBI (ICDR) Regulations, as amended, as present issue is a fixed price issue ‘the allocation’ is the net offer to the public category shall be made as follows:

- a) Minimum fifty percent to Retail Individual Investors; and
- b) Remaining to Investors Other than Retail Individual Investors
- c) The unsubscribed portion in either of the categories specified in (a) or (b) above may be allocated to the applicants in the other category.

"if the retail individual investor category is entitled to more than fifty per cent on proportionate basis, the retail individual investors shall be allocated that higher percentage"

Issue Programme

ISSUE OPENS ON	THURSDAY, JUNE 26, 2014
ISSUE CLOSES ON	MONDAY, JUNE 30, 2014

Applications and any revisions to the same will be accepted only between 10.00 a.m. and 5.00 p.m. (Indian Standard Time) during the Issue Period at the Application Centers mentioned in the Application Form, or in the case of ASBA Applicants, at the Designated Bank Branches.

Applications will be accepted only on Working Days, i.e., Monday to Friday (excluding any public holiday).

ISSUE PROCEDURE

This section applies to all the Applicants. Please note that all the Applicants are required to make payment of the full Application Amount along with the Application Form.

Our Company and the LM are not liable for any amendments, modifications or changes in applicable laws or regulations, which may occur after the date of the Prospectus.

Fixed Price Issue

This Issue is being made in terms of Chapter XB of the SEBI (ICDR) Regulations under Regulation 43(3) of the SEBI (ICDR) Regulations by way of a Fixed Price Issue wherein at least 50% of the Net Issue to the Public shall be available for allocation to Retail Individual Investors and the remaining shall be available for allocation to applicants other than Retail Individual Investors irrespective of the number of specified securities applied for.

Under-subscription, if any, in the aforementioned categories may be allocated to the applicants in other category.

Applicants are required to submit their Applications to the Selected Branches/Offices of the Escrow Bankers to the Issue who shall duly submit to them the Registrar to the Issue. In case of QIB Applicants, the Company in consultation with the LM may reject Applications at the time of acceptance of Application Form provided that the reasons for such rejection shall be provided to such Applicant in writing.

In case of Non-Institutional Applicants and Retail Individual Applicants, our Company would have a right to reject the Applications only on technical grounds.

Investors should note that according to section 29(1) of the Companies Act, 2013, allotment of Equity Shares to all successful Applicants will only be in the dematerialised form. The Application Forms which do not have the details of the Applicant's depository account including DP ID, PAN and Beneficiary Account Number shall be treated as incomplete and rejected. In case DP ID, Client ID and PAN mentioned in the Application Form and entered into the electronic application system of the stock exchanges by the Brokers (including sub-brokers) do not match with the DP ID, Client ID and PAN available in the depository database, the application is liable to be rejected. Applicants will not have the option of getting allotment of the Equity Shares in physical form. The Equity Shares on allotment shall be traded only in the dematerialised segment of the Stock Exchanges.

Applicants are required to ensure that the PAN (of the sole/ first Applicant) provided in the Application Form is exactly the same as the PAN of the person(s) in whose name the relevant beneficiary account is held. In case of joint Applications, the Application Form should contain only the name of the first Applicant whose name should also appear as the first holder of the beneficiary account held in joint names. The signature of only such first Applicant would be required in the Application Form and such first Applicant would be deemed to have signed on behalf of the joint holders.

Application Form

Applicants shall only use the specified Application Form bearing the stamp of the Bankers to the Issue for the purpose of making an Application in terms of this Prospectus. The application form shall contain space for indicating number of specified securities subscribed for in dematerialised form. Upon completing and submitting the Application Form to the Bankers to the Issue, the Applicant is deemed to have authorized our Company to make the necessary changes in the Prospectus and the Application Form as would be required for filing the Prospectus with the RoC and as would be required by RoC after such filing, without prior or subsequent notice of such changes to the Applicant.

ASBA Applicants shall submit an Application Form either in physical or electronic form to the SCSB's authorizing blocking funds that are available in the bank account specified in the Application Form used by ASBA Applicants. Upon completing and submitting the Application Form for ASBA Applicants to the SCSB, the ASBA Applicant is deemed to have authorized our Company to make the necessary changes in the Prospectus and the ASBA Application as would be required for filing the Prospectus with the RoC and as would be required by RoC after such filing, without prior or subsequent notice of such changes to the ASBA Applicant.

The prescribed colour of the Application Form for various categories is as follows:

Bansal Roofing Products Limited

Category	Colour
Indian Public / NRI's applying on a non-repatriation basis (ASBA and Non-ASBA).	White
Non-Residents including eligible NRI's, etc. applying on a repatriation basis (ASBA and Non-ASBA).	Blue

In accordance with the SEBI (ICDR) Regulations in public issues with effect from May 1, 2010 all the investors can apply through ASBA process and with effect from May 2, 2011, the Non-Institutional applicants and the QIB Applicants have to compulsorily apply through the ASBA Process.

Availability of Prospectus and Application Forms

The Memorandum Form 2A containing the salient features of the Prospectus together with the Application Forms and copies of the Prospectus may be obtained from the Registered Office of our Company, LM to the Issue, Registrar to the Issue and the collection centers of the Bankers to the Issue, as mentioned in the Application Form. The Application Forms may also be downloaded from the website of BSE Limited i.e. www.bseindia.com.

Who can Bid?

1. Indian nationals resident in India who are not minors, or in the name of the minor children as natural / legal guardians in single or joint names (not more than three).
2. Hindu Undivided Families or HUFs in the individual name of the Karta. The Applicant should specify that the Application is being made in the name of the HUF in the Application Form as follows: "Name of sole or first Applicant: XYZ Hindu Undivided Family applying through XYZ, where XYZ is the name of the Karta". Applications by HUFs would be considered at par with those from individuals.
3. Eligible NRIs on a repatriation basis or a non-repatriation basis subject to compliance with applicable laws. NRIs, other than Eligible NRIs, are not permitted to participate in this Issue.
4. Foreign institutional investor (FIIs) and sub-account registered with SEBI, other than a sub-account which is a foreign corporate or foreign individual.
5. Sub-accounts of FIIs registered with SEBI, which are foreign corporate or foreign individuals, only under the Non Institutional Portion.
6. State Industrial Development Corporations.
7. Insurance companies registered with the Insurance Regulatory and Development Authority, India constituted under the Insurance Regulatory and Development Authority Act, 1999.
8. Provident Funds with a minimum corpus of ₹ 2,500.00 lakhs and who are authorized under their constitution to invest in Equity Shares.
9. Pension funds with a minimum corpus of ₹ 2,500.00 lakhs and who are authorized under their constitution to invest in Equity Shares.
10. Companies, corporate bodies and societies registered under applicable laws in India and authorized to invest in Equity Shares.
11. Venture Capital Funds (VCFs) registered with SEBI.
12. Foreign Venture Capital Investors (FVCIs) registered with the SEBI under the SEBI (Foreign Venture Capital Investors) Regulations
13. Eligible QFIs.
14. Mutual Funds registered with SEBI.
15. Indian financial institutions, scheduled commercial banks (excluding foreign banks), regional rural banks, cooperative banks (subject to the RBI regulations and the SEBI (ICDR) Regulations and other regulations, as applicable)
16. Multilateral and bilateral development financial institutions.
17. Trusts/societies registered under the Societies Registration Act, 1860, as amended, or under any other law relating to trusts and who are authorized under their constitution to hold and invest in Equity Shares.
18. Scientific and/or industrial research organizations in India authorized to invest in Equity Shares.
19. National Investment Fund set up by resolution No. F.No.2/3/2005-DDII dated November 23, 2005 of the Government of India published in the Gazette of India
20. Nominated Investor and Market Maker.
21. Insurance funds set up and managed by army, navy or air force of the Union of India.
22. Insurance funds set up and managed by the Department of Posts, India.
23. Limited Liability Partnerships and
24. Any other person eligible to apply in this Issue, under the laws, rules, regulations, guidelines and policies applicable to them under Indian laws.

Applications cannot be made by:

1. Minors
2. Partnership firms or their nominations
3. Foreign Nationals (except NRIs)
4. Overseas Corporate Bodies

MAXIMUM AND MINIMUM APPLICATION SIZE

1. For Retail Individual Applicants

The Application must be for a minimum of 4000 Equity Shares and in multiples of 4000 Equity Shares thereafter, so as to ensure that the Application Price payable by the Applicant does not exceed ₹ 2,00,000. In case of revision of Applications, the Retail Individual Applicants have to ensure that the Application Price does not exceed ₹ 2,00,000.

2. For Other than Retail Individual Applicants (Non-Institutional Applicants and QIBs):

The Application must be for a minimum of such number of Equity Shares such that the Application Amount exceeds ₹ 2,00,000 and in multiples of 4000 Equity Shares thereafter. An Application cannot be submitted for more than the Net Issue Size. However, the maximum Application by a QIB investor should not exceed the investment limits prescribed for them by applicable laws. Under existing SEBI Regulations, a QIB Applicant cannot withdraw its Application after the Issue Closing Date and is required to pay 100% QIB Margin upon submission of Application.

In case of revision in Applications, the Non-Institutional Applicants, who are individuals, have to ensure that the Application Amount is greater than ₹ 2,00,000 for being considered for allocation in the Non-Institutional Portion.

Applicants are advised to ensure that any single Application from them does not exceed the investment limits or maximum number of Equity Shares that can be held by them under applicable law or regulation or as specified in this Prospectus.

Participation by Associates of LMs

Except for the Market Making and the Underwriting Obligations, the LM shall not be allowed to subscribe to this Issue in any manner. However, associates and affiliates of the LMs may subscribe to or purchase Equity Shares in the Issue, where the allocation is on a proportionate basis.

Option to Subscribe in the Issue

- a. Pursuant to the provisions of Section 29(1) of the Companies Act, 1956, allotment of specified securities shall be made only in dematerialized form.
- b. The Equity Shares, on allotment, shall be traded on the Stock Exchange in demat segment only.

Information for the Applicants:

- a) Our Company will file the Prospectus with the RoC at least 3 (three) Days before the Issue Opening Date.
- b) The LMs will circulate copies of the Prospectus along with the Application Form to potential investors.
- c) Any investor (who is eligible to invest in our Equity Shares) who would like to obtain the Prospectus and/ or the Application Form can obtain the same from our registered office or from the corporate office of the LMs.
- d) Applicants who are interested in subscribing for the Equity Shares should approach the LMs or their authorized agent(s) to register their Applications.
- e) Applications made in the Name of Minors and/or their nominees shall not be accepted.

Bansal Roofing Products Limited

- f) Applicants are requested to mention the application form number on the reverse of the instrument to avoid misuse of instrument submitted along with the application for shares. Applicants are advised in their own interest, to indicate the name of the bank and the savings or current a/c no in the application form. In case of refund, the refund order will indicate these details after the name of the payee. The refund order will be sent directly to the payee's address.

Application by Indian Public including eligible NRIs applying on Non-Repatriation

Application must be made only in the names of individuals, Limited Companies or Statutory Corporations/institutions and not in the names of Minors, Foreign Nationals, Non Residents Indian (except for those applying on non-repatriation), trusts, (unless the Trust is registered under the Societies Registration Act, 1860 or any other applicable Trust laws and is authorized under its constitution to hold shares and debentures in a Company), Hindu Undivided Families, partnership firms or their nominees. In case of HUF's application shall be made by the Karta of the HUF. An applicant in the Net Public Category cannot make an application for that number of securities exceeding the number of securities offered to the public.

Application by Mutual Funds

As per the current regulations, the following restrictions are applicable for investments by mutual funds:

No mutual fund scheme shall invest more than 10% of its net asset value in the Equity Shares or equity related instruments of any Company provided that the limit of 10% shall not be applicable for investments in index funds or sector or industry specific funds. No mutual fund under all its schemes should own more than 10% of any Company's paid up share capital carrying voting rights.

The Applications made by the asset management companies or custodians of Mutual Funds shall specifically state the names of the concerned schemes for which the Applications are made.

With respect to Applications by Mutual Funds, a certified copy of their SEBI registration certificate must be lodged with the Application Form. Failing this, our Company reserves the right to accept or reject any Application in whole or in part, in either case, without assigning any reason thereof.

In case of a Mutual Fund, a separate Application can be made in respect of each scheme of the Mutual Fund registered with SEBI and such Applications in respect of more than one scheme of the Mutual Fund will not be treated as multiple Applications provided that the Applications clearly indicate the scheme concerned for which the Application has been made.

Applications by Eligible NRIs/FII's on Repatriation Basis

Application Forms have been made available for Eligible NRIs at our Registered Office.

Eligible NRI applicants may please note that only such applications as are accompanied by payment in free foreign exchange shall be considered for Allotment under the reserved category. The Eligible NRIs who intend to make payment through Non Resident Ordinary (NRO) accounts shall use the form meant for Resident Indians and shall not use the forms meant for reserved category.

Under the Foreign Exchange Management Act, 1999 (FEMA) general permission is granted to the companies vide notification no. FEMA/20/2000 RB dated 03/05/2000 to issue securities to NRI's subject to the terms and conditions stipulated therein. The Companies are required to file the declaration in the prescribed form to the concerned Regional Office of RBI within 30 (thirty) days from the date of issue of shares for allotment to NRI's on repatriation basis.

Allotment of Equity Shares to Non-Resident Indians shall be subject to the prevailing Reserve Bank of India Guidelines. Sale proceeds of such investments in Equity Shares will be allowed to be repatriated along with the income thereon subject to permission of the RBI and subject to the Indian Tax Laws and regulations and any other applicable laws.

Our Company does not require approvals from FIPB or RBI for the Transfer of Equity Shares in the issue to eligible NRI's.

As per the current regulations, the following restrictions are applicable for investments by FIIs:

Bansal Roofing Products Limited

The issue of Equity Shares to a single FII should not exceed 10% of our post Issue capital. In respect of an FII investing in our equity shares on behalf of its sub accounts, the investment on behalf of each sub account shall not exceed 10% of our total issued capital or 5% of our total issued capital in case such sub account is a foreign corporate or an individual.

In accordance with the foreign investment limits, the aggregate FII holding in our Company cannot exceed 24% of our total issued capital. With the approval of the board and the shareholders by way of a special resolution, the aggregate FII holding can go up to 100%. However, as on this date, no such resolution has been recommended to the shareholders of the Company for adoption.

Subject to compliance with all applicable Indian laws, rules, regulations, guidelines and approvals in terms of regulation 15A(1) of the Securities Exchange Board of India (Foreign Institutional Investors) Regulations 1995, as amended, an FII may issue, deal or hold, off shore derivative instruments such as participatory notes, equity linked notes or any other similar instruments against underlying securities listed or proposed to be listed in any stock exchange in India only in favour of those entities which are regulated by any relevant regulatory authorities in the countries of their incorporation or establishment subject to compliance of "Know Your Client" requirements. An FII shall also ensure that no further downstream issue or transfer of any instrument referred to hereinabove is made to any person other than a regulated entity.

In case of FII's in NRI/FII Portion, number of Equity Shares applied shall not exceed net issue size.

Applications by Eligible QFIs

Eligible QFIs are permitted to invest in the equity shares of Indian companies on a repatriation basis subject to certain terms and conditions. Eligible QFIs have also been permitted to invest in equity shares of Indian companies which are offered to the public in India in accordance with the SEBI Regulations. The individual and aggregate investment limits for Eligible QFIs in an Indian company are 5.00% and 10.00% of the paid up capital of the Indian company respectively. These limits are in addition to the investment limits prescribed under the portfolio investment scheme for FIIs and NRIs. However, in cases of those sectors which have composite foreign investment caps, Eligible QFI investment limits are required to be considered within such composite foreign investment cap. An Eligible QFI may make investments in the equity shares of an Indian company through both the FDI route and the QFI route. However, the aggregate holding of such Eligible QFI shall not exceed 5.00% of the paid-up capital of the Indian company at any point of time.

QFIs shall be eligible to apply under the Non-Institutional Applicants category. Further, SEBI in its circular dated January 13, 2012 has specified, amongst other things, eligible transactions for Eligible QFIs (which includes investment in equity shares in public issues to be listed on recognised stock exchanges and sale of equity shares held by Eligible QFIs in their demat account through SEBI registered brokers), manner of operation of demat accounts by Eligible QFIs, transaction processes and investment restrictions. SEBI has specified that transactions by Eligible QFIs shall be treated at par with those made by Indian non-institutional investors in various respects including, margins, voting rights, public issues, etc.

Eligible QFIs shall open a single non-interest bearing Rupee account with an AD category-I bank in India for routing the payment for transactions relating to purchase of equity shares (including investment in equity shares in public issues) subject to the conditions as may be prescribed by the RBI from time to time. Eligible QFIs who wish to participate in the Issue are advised to use the Application Form meant for Non- Residents (blue in colour). Eligible QFIs shall compulsorily apply through the ASBA process to participate in the Issue.

Applications by SEBI registered Venture Capital Funds, Alternative Investment Funds and Foreign Venture Capital Investors

As per the current regulations, the following restrictions are applicable for SEBI Registered Venture Capital Funds:

The SEBI (Venture Capital) Regulations, 1996 prescribe investment restrictions on venture capital funds registered with SEBI.

Accordingly, the holding by any individual venture capital fund registered with SEBI in one Company should not exceed 25% of the corpus of the venture capital fund. Further, Venture Capital Funds can invest only up to 33.33% of the investible funds by way of subscription to an initial public offer.

The Category I and II AIFs cannot invest more than 25% of their respective corpus in one Investee Company. A category III AIF cannot invest more than 10% of its corpus in one Investee Company. A venture capital fund - 634 - registered as a category I AIF, as defined in the SEBI (Alternate Investment Funds) Regulations, 2012, cannot invest more than 1/3rd of its corpus by way of subscription to an initial public offering of a venture capital undertaking. Additionally, the VCFs

Bansal Roofing Products Limited

which have not re-registered as an AIF under the SEBI (Alternate Investment Funds) Regulations, 2012 shall continue to be regulated by the VCF Regulations.

Applications by Limited Liability Partnerships

In case of Applications made by limited liability partnerships registered under the Limited Liability Partnership Act, 2008, as amended ("**LLP Act**") a certified copy of certificate of registration issued under the LLP Act must be attached to the Application Form. Failing this, our Company reserves the right to reject any Application without assigning any reason thereof.

Applications by Insurance Companies

In case of Applications made by insurance companies registered with the IRDA, a certified copy of certificate of registration issued by IRDA must be attached to the Application Form or the ASBA Application Form, as the case may be. Failing this, our Company in consultation with the LM, reserve the right to reject any Application without assigning any reason thereof. The exposure norms for insurers, prescribed under the Insurance Regulatory and Development Authority (Investment) Regulations, 2000, as amended, are broadly set forth below:

- 1) equity shares of a company: the least of 10% of the investee company's subscribed capital (face value) or 10% of the respective fund in case of life insurer or 10% of investment assets in case of general insurer or reinsurer;
- 2) the entire group of the investee company: the least of 10% of the respective fund in case of a life insurer or 10% of investment assets in case of a general insurer or reinsurer (25% in case of ULIPs); and
- 3) the industry sector in which the investee company operates: 10% of the insurer's total investment exposure to the industry sector (25% in case of ULIPs).

Applications under Power of Attorney

In case of Applications made pursuant to a power of attorney or by limited companies, corporate bodies, registered societies, a certified copy of the power of attorney or the relevant resolution or authority, as the case may be, along with a certified copy of the Memorandum of Association and Articles of Association and/ or bye laws must be lodged along with the Application Form. Failing this, the Company reserves the right to accept or reject any Application in whole or in part, in either case, without assigning any reason thereof.

In case of Applications made pursuant to a power of attorney by Mutual Funds, a certified copy of the power of attorney or the relevant resolution or authority, as the case may be, along with the certified copy of their SEBI registration certificate must be lodged along with the Application Form. Failing this, the Company reserves the right to accept or reject any Application in whole or in part, in either case, without assigning any reason thereof.

In case of Applications made by insurance companies registered with the Insurance Regulatory and Development Authority, a certified copy of certificate of registration issued by Insurance Regulatory and Development Authority must be lodged along with the Application Form. Failing this, the Company reserves the right to accept or reject any Application in whole or in part, in either case, without assigning any reason thereof.

In case of Applications made pursuant to a power of attorney by FIIs, a certified copy of the power of attorney or the relevant resolution or authority, as the case may be, along with a certified copy of their SEBI registration certificate must be lodged along with the Application Form. Failing this, the Company reserves the right to accept or reject any Application in whole or in part, in either case, without assigning any reason thereof.

In case of Applications made by provident funds with minimum corpus of ₹ 25 crore (subject to applicable law) and pension funds with minimum corpus of ₹ 25 crore, a certified copy of certificate from a Chartered Accountant certifying the corpus of the provident fund/ pension fund must be lodged along with the Application Form. Failing this, the Company reserves the right to accept or reject any Application in whole or in part, in either case, without assigning any reason thereof.

The Company in its absolute discretion, reserve the right to relax the above condition of simultaneous lodging of the power of attorney along with the Application Form, subject to such terms and conditions that the Company and the LMs may deem fit.

Application by Provident Funds/ Pension Funds

In case of Applications made by provident funds with minimum corpus of ₹25 crore (subject to applicable law) and pension funds with minimum corpus of ₹25 crore, a certified copy of certificate from a chartered accountant certifying the corpus of the provident fund/ pension fund must be lodged along with the Application Form. Failing this, our Company reserves the right to accept or reject any Application in whole or in part, in either case, without assigning any reason thereof.

The above information is given for the benefit of the Applicants. The Company and the LMs are not liable for any amendments or modification or changes in applicable laws or regulations, which may occur after the date of this Prospectus. Applicants are advised to make their independent investigations and ensure that the number of Equity Shares applied for do not exceed the applicable limits under laws or regulations.

ISSUE PROCEDURE FOR ASBA (APPLICATION SUPPORTED BY BLOCKED ACCOUNT) APPLICANTS

This section is for the information of investors proposing to subscribe to the Issue through the ASBA process. Our Company and the LMs are not liable for any amendments, modifications, or changes in applicable laws or regulations, which may occur after the date of this Prospectus. ASBA Applicants are advised to make their independent investigations and to ensure that the ASBA Application Form is correctly filled up, as described in this section.

The lists of banks that have been notified by SEBI to act as SCSB (Self Certified Syndicate Banks) for the ASBA Process are provided on <http://www.sebi.gov.in>. For details on designated branches of SCSB collecting the Application Form, please refer the above mentioned SEBI link.

ASBA Process

A Resident Retail Individual Investor shall submit his Application through an Application Form, either in physical or electronic mode, to the SCSB with whom the bank account of the ASBA Applicant or bank account utilized by the ASBA Applicant ("ASBA Account") is maintained. The Application Form shall bear the stamp of the SCSBs and if not, the same shall be rejected.

Application Form, physical or electronic, on the basis of an authorization to this effect given by the account holder at the time of submitting the Application. The SCSB shall block an amount equal to the Application Amount in the bank account specified in the ASBA. The Application Amount shall remain blocked in the aforesaid ASBA Account until finalization of the Basis of Allotment in the Issue and consequent transfer of the Application Amount against the allocated shares to the ASBA Public Issue Account, or until withdrawal/failure of the Issue or until withdrawal/rejection of the ASBA Application, as the case may be.

The ASBA data shall thereafter be uploaded by the SCSB in the electronic IPO system of the Stock Exchange. Once the Basis of Allotment is finalized, the Registrar to the Issue shall send an appropriate request to the Controlling Branch of the SCSB for unblocking the relevant bank accounts and for transferring the amount allocable to the successful ASBA Applicants to the ASBA Public Issue Account.

In case of withdrawal/failure of the Issue, the blocked amount shall be unblocked on receipt of such information from the LMs.

ASBA Applicants are required to submit their Applications, either in physical or electronic mode. In case of application in physical mode, the ASBA Applicant shall submit the ASBA Application Form at the Designated Branch of the SCSB. In case of application in electronic form, the ASBA Applicant shall submit the Application Form either through the internet banking facility available with the SCSB, or such other electronically enabled mechanism for applying and blocking funds in the ASBA account held with SCSB, and accordingly registering such Applications.

Who can apply?

In accordance with the SEBI (ICDR) Regulations, 2009 in public issues w.e.f. May 1, 2010 all the investors can apply through ASBA process and w.e.f May 02, 2011, the Non-Institutional applicants and the QIB Applicants have to compulsorily apply through the ASBA Process.

Mode of Payment

Upon submission of an Application Form with the SCSB, whether in physical or electronic mode, each ASBA Applicant shall be deemed to have agreed to block the entire Application Amount and authorized the Designated Branch of the SCSB to block the Application Amount, in the bank account maintained with the SCSB.

Application Amount paid in cash, by money order or by postal order or by stock invest, or ASBA Application Form accompanied by cash, draft, money order, postal order or any mode of payment other than blocked amounts in the SCSB bank accounts, shall not be accepted.

After verifying that sufficient funds are available in the ASBA Account, the SCSB shall block an amount equivalent to the Application Amount mentioned in the ASBA Application Form till the Designated Date.

On the Designated Date, the SCSBs shall transfer the amounts allocable to the ASBA Applicants from the respective ASBA Account, in terms of the SEBI Regulations, into the ASBA Public Issue Account. The balance amount, if any against the said Application in the ASBA Accounts shall then be unblocked by the SCSBs on the basis of the instructions issued in this regard by the Registrar to the Issue.

The entire Application Amount, as per the Application Form submitted by the respective ASBA Applicants, would be required to be blocked in the respective ASBA Accounts until finalization of the Basis of Allotment in the Issue and consequent transfer of the Application Amount against allocated shares to the ASBA Public Issue Account, or until withdrawal/failure of the Issue or until rejection of the ASBA Application, as the case may be.

Unblocking of ASBA Account

On the basis of instructions from the Registrar to the Issue, the SCSBs shall transfer the requisite amount against each successful ASBA Applicant to the ASBA Public Issue Account and shall unblock excess amount, if any in the ASBA Account. However, the Application Amount may be unblocked in the ASBA Account prior to receipt of intimation from the Registrar to the Issue by the Controlling Branch of the SCSB regarding finalization of the Basis of Allotment in the Issue, in the event of withdrawal/failure of the Issue or rejection of the ASBA Application, as the case may be.

Payment mechanism for ASBA Applications

All investors other than retail individual investors are required to make their application using ASBA process only.

The ASBA applicants shall specify the bank account number in the Application Form and the SCSB shall block an amount equivalent to the Application Amount in the ASBA Account specified in the Application Form. The SCSB shall keep the Application Amount in the relevant bank account blocked until withdrawal/ rejection of the ASBA Application or receipt of instructions from the Registrar to the Issue to unblock the Application Amount. In the event of withdrawal or rejection of the Application Form or for unsuccessful -Application Forms, the Registrar to the Issue shall give instructions to the SCSB to unblock the application money in the relevant bank account within one day of receipt of such instruction. The Application Amount shall remain blocked in the ASBA Account until finalisation of the Basis of Allotment in the Issue and consequent transfer of the Application Amount to the Public Issue Account, or until withdrawal/ failure of the Issue or until withdrawal of the Application by the ASBA Applicant, , as the case may be.

In case of Applications by Eligible NRIs applying on repatriation basis, a NRE Account or a FCNR Account, maintained with banks authorized to deal in foreign exchange in India, should be mentioned in the Application Form for blocking of funds, along with documentary evidence in support of the remittance.

In case of Applications by Eligible NRIs applying on a non-repatriation basis, a NRE Account or a FCNR Account maintained with banks authorized to deal in foreign exchange in India or a NRO Account, should be mentioned in the Application Form for blocking of funds, along with documentary evidence in support of the remittance.

Escrow Mechanism

Terms of Payment / Payment Instructions

The entire issue price of ₹ 30.00 per share is payable on application. In case of allotment of lesser number of Equity Shares than the number applied, our Company shall refund the excess amount paid on Application to the Applicants.

Bansal Roofing Products Limited

Where the payment is made other than ASBA, it should be made by cheque, or demand draft drawn on any Bank (including a Co-operative Bank), which is situated at, and is a member of or sub member of the bankers' clearing house located at the centre where the Application Form is submitted. Outstation cheques/ bank drafts drawn on banks not participating in the clearing process will not be accepted and applications accompanied by such cheques or bank drafts are liable to be rejected.

Cash/ Stock invest/ Money Orders/ Postal orders will not be accepted.

A separate Cheque or Bank Draft should accompany each application form where payment is made other than ASBA mechanism. Applicants should write the Share Application Number on the back of the Cheque /Draft. Outstation Cheques will not be accepted and applications accompanied by such cheques drawn on outstation banks are liable for rejection.

Each Applicant shall draw a cheque or demand draft for the amount payable on the Application and/ or on allocation/ Allotment as per the following terms:

1. The payment instruments for payment into the Escrow Account should be drawn in favour of:
 1. Indian Public including eligible NRIs applying on non-repatriation basis: "BANSAL ROOFING PRODUCTS LIMITED - PUBLIC ISSUE - R".
 2. In case of Non-Resident Retail Applicants applying on repatriation basis: " BANSAL ROOFING PRODUCTS LIMITED - PUBLIC ISSUE - NR"
2. In case of Application by NRIs applying on repatriation basis, the payments must be made through Indian Rupee drafts purchased abroad or cheques or bank drafts, for the amount payable on application remitted through normal banking channels or out of funds held in Non-Resident External (NRE) Accounts or Foreign Currency Non Resident (FCNR) Accounts, maintained with banks authorized to deal in foreign exchange in India, along with documentary evidence in support of the remittance. Payment will not be accepted out of Non-Resident Ordinary (NRO) Account of Non-Resident Applicant applying on a repatriation basis. Payment by drafts should be accompanied by bank certificate confirming that the draft has been issued by debiting to NRE Account or FCNR Account.
3. Where an Applicant has been allocated a lesser number of Equity Shares than the Applicant has applied for, the excess amount, if any, paid on Application, after adjustment towards the balance amount payable by the Pay-in-Date on the Equity Shares allocated will be refunded to the Applicant from the Refund Account.
4. On the Designated Date and no later than 15 (fifteen) Working Days from the Issue Closing Date, the Escrow Collection Bank shall also refund all amounts payable to unsuccessful Applicants and also the excess amount paid on Application, if any, after adjusting for allocation / Allotment to the Applicants.

Payment by Stock invest

In terms of the Reserve Bank of India Circular No. DBOD No. FSC BC 42/ 24.47.00/ 2003 04 dated November 5, 2003; the option to use the stock invest instrument in lieu of cheques or bank drafts for payment of Application money has been withdrawn. Hence, payment through stock invest would not be accepted in this Issue.

Other Instructions

Joint Applications in the case of Individuals

Applications may be made in single or joint names (not more than three (3)). In the case of joint Applications, all payments will be made out in favour of the Applicant whose name appears first in the Application Form or Revision Form. All communications will be addressed to the First Applicant and will be dispatched to his or her address as per the Demographic Details received from the Depository.

Multiple Applications

An Applicant should submit only one Application (and not more than one (1)) for the total number of Equity Shares required. Two (2) or more Applications will be deemed to be multiple Applications if the sole or First Applicant is one and the same.

In this regard, the procedures which would be followed by the Registrar to the Issue to detect multiple applications are given below:

- i. All applications are electronically strung on first name, address (1st line) and applicant's status. Further, these applications are electronically matched for common first name and address and if matched, these are checked manually for age, signature and father/ husband's name to determine if they are multiple applications
- ii. Applications which do not qualify as multiple applications as per above procedure are further checked for common DP ID/ beneficiary ID. In case of applications with common DP ID/ beneficiary ID, they are manually checked to eliminate possibility of data entry error to determine if they are multiple applications.
- iii. Applications which do not qualify as multiple applications as per above procedure are further checked for common PAN. All such matched applications with common PAN are manually checked to eliminate possibility of data capture error to determine if they are multiple applications.
- iv. For Applications from Mutual Funds and FII sub-accounts, submitted under the same PAN, as well as Applications on behalf of the Applicants for whom submission of PAN is not mandatory such as the Central or State Government, an official liquidator or receiver appointed by a court and residents of Sikkim, the Application Forms will be checked for common DP ID and Client ID

In any event, all the allotments shall be done in demat form and no securities shall be allotted in physical form.

After submitting an ASBA Application either in physical or electronic mode, an ASBA Applicant cannot apply (either in physical or electronic mode) to either the same or another Designated Branch of the SCSB and Submission of a second Application in such manner will be deemed a multiple Application and would be rejected. More than one ASBA Applicant may apply for Equity Shares using the same ASBA Account, provided that the SCSBs will not accept a total of more than five Application Forms with respect to any single ASBA Account.

Duplicate copies of Application Forms downloaded and printed from the website of the Stock Exchange bearing the same application number shall be treated as multiple Applications and are liable to be rejected. The Company, in consultation with the LM reserves the right to reject, in its absolute discretion, all or any multiple Applications in any or all categories.

In case of a mutual fund, a separate Application can be made in respect of each scheme of the mutual fund registered with SEBI and such Applications in respect of more than one scheme of the mutual fund will not be treated as multiple Applications provided that the Applications clearly indicate the scheme concerned for which the Application has been made.

In cases where there are more than twenty (20) valid applications having a common address, such shares will be kept in abeyance, post allotment and released on confirmation of "know your client" norms by the depositories. The Company reserves the right to reject, in our absolute discretion, all or any multiple Applications in any or all categories.

Permanent Account Number or PAN

Pursuant to the circular MRD/DoP/Circ 05/2007 dated April 27, 2007, SEBI has mandated Permanent Account Number ("**PAN**") to be the sole identification number for all participants transacting in the securities market, irrespective of the amount of the transaction w.e.f. July 2, 2007. Each of the Applicants should mention his/her PAN allotted under the IT Act. Applications without this information will be considered incomplete and are liable to be rejected. It is to be specifically noted that Applicants should not submit the GIR number instead of the PAN, as the Application is liable to be rejected on this ground.

Please note that Central or State Government and the officials appointed by the courts and investors residing in the State of Sikkim are exempted from specifying their PAN subject to the Depository Participants' verifying the veracity of such claims of the investors in accordance with the conditions and procedures under this section on Issue Procedure.

Right to Reject Applications

Our Company in consultation with the LM may reject Applications provided that the reasons for rejecting the same shall be provided to such Applicant in writing. In case of Non-Institutional Applicants, Retail Individual Applicants who applied, the Company has a right to reject Applications based on technical grounds.

Grounds for Rejections

Applicants are advised to note that Applications are liable to be rejected inter alia on the following technical grounds:

1. Amount paid does not tally with the amount payable for the highest value of Equity Shares applied for;
2. In case of partnership firms, Equity Shares may be registered in the names of the individual partners and no firm as such shall be entitled to apply;
3. Application by persons not competent to contract under the Indian Contract Act, 1872 including minors, insane persons;
4. PAN not mentioned in the Application Form;
5. GIR number furnished instead of PAN;
6. Applications for lower number of Equity Shares than specified for that category of investors;
7. Applications at a price other than the Fixed Price of The Issue;
8. Applications for number of Equity Shares which are less than 4,000 or not in multiples of 4,000;
9. Category not ticked;
10. Multiple Applications as defined in this Prospectus;
11. In case of Application under power of attorney or by limited companies, corporate, trust etc., where relevant documents are not submitted;
12. Applications accompanied by Stock invest/ money order/ postal order/ cash;
13. Signature of sole Applicant is missing;
14. Application Forms are not delivered by the Applicant within the time prescribed as per the Application Forms, Issue Opening Date advertisement and the Prospectus and as per the instructions in the Prospectus and the Application Forms;
15. In case no corresponding record is available with the Depositories that matches three parameters namely, names of the Applicants (including the order of names of joint holders), the Depository Participant's identity (DP ID) and the beneficiary's account number;
16. Applications for amounts greater than the maximum permissible amounts prescribed by the regulations;
17. Applications where clear funds are not available in the Escrow Account as per the final certificate from the Escrow Collection Bank(s);
18. Applications by OCBs;
19. Applications by US persons other than in reliance on Regulation S or "qualified institutional buyers" as defined in Rule 144A under the Securities Act;
20. In case of applications by Individual, the details such as name, date and similar compulsory details as indicated in the application form are missing.
21. Applications by any persons outside India if not in compliance with applicable foreign and Indian laws;
22. Applications that do not comply with the securities laws of their respective jurisdictions are liable to be rejected;
23. Applications by persons prohibited from buying, selling or dealing in the shares directly or indirectly by SEBI or any other regulatory authority;
24. Applications by persons who are not eligible to acquire Equity Shares of the Company in terms of all applicable laws, rules, regulations, guidelines, and approvals;
25. Applications or revisions thereof by QIB Applicants, Non-Institutional Applicants where the Application Amount is in excess of ₹2,00,000, received after 5.00 pm on the Issue Closing Date;
26. Applications not containing the details of Bank Account and / or Depositories Account.
27. Where application is made for allotment in physical mode.
28. Where two or more separate applications for demat and physical are made, the applications for physical shares shall be treated as multiple application and liable for rejection.

APPLICANTS SHOULD NOTE THAT IN CASE THE PAN, THE DP ID AND CLIENT ID MENTIONED IN THE APPLICATION FORM AND ENTERED INTO THE ELECTRONIC APPLICATION SYSTEM OF THE STOCK EXCHANGES BY THE BROKERS DO NOT MATCH WITH PAN, THE DP ID AND CLIENT ID AVAILABLE IN THE DEPOSITORY DATABASE, THE APPLICATION FORM IS LIABLE TO BE REJECTED.

Applicants should note that providing bank account details in the space provided in the application form is mandatory and applications that do not contain such details are liable to be rejected.

IMPERSONATION

Attention of the applicants is specifically drawn to the provisions of section 38(1) of the Companies Act, 2013 which is reproduced below:

Any person who:

- a) Makes or abets making of an application in a fictitious name, to the Company for acquiring or subscribing for, any shares therein, or
- b) Makes or abets making of multiple applications to the Company in different names or in combination of his name or surname for acquiring or subscribing for its securities; or
- c) Otherwise induces directly or indirectly to the Company to allot, or register any transfer of shares therein to him, or any other person in a fictitious name,

shall be liable to action under Section 447 of the Companies Act, 2013.

Section 447 of the Companies Act, 2013, is reproduced as below:

“Without Prejudice to any liability including repayment of any debt under this Act or any other law for the time being in force, any person who is found to be guilty of fraud, shall be punishable with imprisonment for a term which shall not be less than six months but which may exceed to ten years and shall also be liable to fine which shall not be less than the amount involved in the fraud, but which may extend to three times the amount involved in the fraud.

Provided that where the fraud in question involves public interest, the term of imprisonment shall not be less than three years.”

Signing of Underwriting Agreement

Our Company and the LM to the Issue confirm that the Issue is 100% Underwritten. The Issue is 100% underwritten by the LM in the capacity of Underwriter to the Issue. Pursuant to the terms of the Underwriting Agreement dated April 5, 2014 entered into by our Company with Underwriter, LM, the obligations of the Underwriter are subject to certain conditions specified therein.

Filing of the Prospectus with the RoC

The Company will file a copy of the Prospectus with the RoC in terms of Section 26, 31(1) and 31(2) of the Companies Act, 2013.

Pre-Issue Advertisement

Subject to Section 30 of the Companies Act 2013, the Company, the Company shall, after registering the Prospectus with the RoC, publish a pre-Issue advertisement, in the form prescribed by the SEBI Regulations, in one widely circulated English language national daily newspaper; one widely circulated Hindi language national daily newspaper and one regional newspaper with wide circulation.

Designated Date and Allotment of Equity Shares

The Company will issue and dispatch letters of allotment / securities certificates and / or letters of regret along with refund order or credit the allotted securities to the respective beneficiary accounts, if any within a period of 15 (fifteen) days of the Issue Closing Date.

In case our Company issues Letters of allotment, the corresponding Security Certificates will be kept ready within 3 (three) months from the date of allotment thereof or such extended time as may be approved by the Company Law Board under Section 56 of the Companies Act, 2013 or other applicable provisions, if any. Allottees are requested to preserve such Letters of Allotment, which would be exchanged later for the Security Certificates.

After the funds are transferred from the Escrow Account to the Public Issue Account on the Designated Date, our Company would ensure the credit to the successful Applicants depository account. Allotment of the Equity Shares to the allottees shall be within 2 (two) Working Days of the date of Allotment.

Investors are advised to instruct their Depository Participant to accept the Equity Shares that may be allocated/ Allotted to them pursuant to this Issue.

Applicants to whom refunds are made through electronic transfer of funds will be sent a letter intimating them about the mode of credit of refund within 15 (fifteen) days of closure of Issue.

Our Company will provide adequate funds required for dispatch of refund orders or allotment advice to the Registrar to the Issue.

Refunds will be made by cheques, pay orders or demand drafts drawn on a bank appointed by us, as Refund Banker and payable at par at places where applications are received. Bank charges, if any, for en-cashing such cheques, pay orders or demand drafts at other centers will be payable by the Applicants.

General Instructions

Do's:

1. Check if you are eligible to apply;
2. Read all the instructions carefully and complete the applicable Application Form;
3. Ensure that the details about Depository Participant and Beneficiary Account are correct as Allotment of Equity Shares will be in the dematerialized form only;
4. Each of the Applicants should mention their Permanent Account Number (PAN) allotted under the Income Tax Act, 1961;
5. Ensure that the Demographic Details (as defined herein below) are updated, true and correct in all respects;
6. Ensure that the name(s) given in the Application Form is exactly the same as the name(s) in which the beneficiary account is held with the Depository Participant.
7. Ensure that in case of Applications are made under power of attorney or Applications by limited companies, corporate, trusts etc., relevant documents are submitted.
8. Ensure that Applications submitted by any person resident outside India should be in compliance with applicable foreign and Indian laws.

Don'ts:

1. Do not apply for lower than the minimum Application size;
2. Do not apply at a Price Different from the Price Mentioned herein or in the Application Form
3. Do not apply on another Application Form after you have submitted an Application to the Bankers of the Issue.
4. Do not pay the Application Price in cash, by money order or by postal order or by stock invest;
5. Do not send Application Forms by post; instead submit the same to the Selected Branches / Offices of the Banker to the Issue.
6. Do not fill up the Application Form such that the Equity Shares applied for exceeds the Issue Size and/ or investment limit or maximum number of Equity Shares that can be held under the applicable laws or regulations or maximum amount permissible under the applicable regulations;
7. Do not submit the GIR number instead of the PAN as the Application is liable to be rejected on this ground.

Instructions for Completing the Application Form

The Applications should be submitted on the prescribed Application Form and in BLOCK LETTERS in ENGLISH only in accordance with the instructions contained herein and in the Application Form. Applications not so made are liable to be rejected. ASBA Application Forms should bear the stamp of the SCSB's. ASBA Application Forms, which do not bear the stamp of the SCSB, will be rejected.

Applicants residing at places where the designated branches of the Banker to the Issue are not located may submit/mail their applications at their sole risk along with Demand Draft payable at Mumbai.

Applicant's Depository Account and Bank Details

Applicants should note that on the basis of name of the Applicants, Depository Participant's name, Depository Participant Identification number and Beneficiary Account Number provided by them in the Application Form, the Registrar to the Issue will obtain from the Depository the demographic details including address, Applicants bank account details, MICR

Bansal Roofing Products Limited

code and occupation (hereinafter referred to as 'Demographic Details'). These Bank Account details would be used for giving refunds to the Applicants. Hence, Applicants are advised to immediately update their Bank Account details as appearing on the records of the depository participant. Please note that failure to do so could result in delays in dispatch/credit of refunds to Applicants at the Applicants sole risk and neither the LMs or the Registrar or the Escrow Collection Banks or the SCSB nor our Company shall have any responsibility and undertake any liability for the same. Hence, Applicants should carefully fill in their Depository Account details in the Application Form.

These Demographic Details would be used for all correspondence with the Applicants including mailing of the CANs / Allocation Advice and printing of Bank particulars on the refund orders or for refunds through electronic transfer of funds, as applicable. The Demographic Details given by Applicants in the Application Form would not be used for any other purpose by the Registrar to the Issue.

By signing the Application Form, the Applicant would be deemed to have authorized the depositories to provide, upon request, to the Registrar to the Issue, the required Demographic Details as available on its records.

Applicants should note that providing bank account details in the space provided in the application form is mandatory and applications that do not contain such details are liable to be rejected.

Basis of Allotment

Allotment will be made in consultation with SME Exchange. In the event of oversubscription, the allotment will be made on a proportionate basis in marketable lots as set forth here:

1. The total number of Shares to be allocated to each category as a whole shall be arrived at on a proportionate basis i.e. the total number of Shares applied for in that category multiplied by the inverse of the over subscription ratio (number of applicants in the category x number of Shares applied for).
2. The number of Equity Shares to be allocated to the successful applicants will be arrived at on a proportionate basis in marketable lots (i.e. Total number of Shares applied for into the inverse of the over subscription ratio).
3. For applications where the proportionate allotment works out to less than 4,000 Equity Shares the allotment will be made as follows:
 - a) Each successful applicant shall be allotted 4,000 Equity Shares; and
 - b) The successful applicants out of the total applicants for that category shall be determined by the drawal of lots in such a manner that the total number of Shares allotted in that category is equal to the number of Shares worked out as per (2) above.
4. If the proportionate allotment to an applicant works out to a number that is not a multiple of 4,000 Equity Shares, the applicant would be allotted Shares by rounding off to the lower nearest multiple of 4,000 Equity Shares subject to a minimum allotment of 4,000 Equity Shares.
5. If the Shares allotted on a proportionate basis to any category is more than the Shares allotted to the applicants in that category, the balance available Shares for allocation shall be first adjusted against any category, where the allotted Shares are not sufficient for proportionate allotment to the successful applicants in that category, the balance Shares, if any, remaining after such adjustment will be added to the category comprising of applicants applying for the minimum number of Shares. If as a result of the process of rounding off to the lower nearest multiple of 4,000 Equity Shares, results in the actual allotment being higher than the shares offered, the final allotment may be higher at the sole discretion of the Board of Directors, upto 110% of the size of the offer specified under the Capital Structure mentioned in this Prospectus.
6. The above proportionate allotment of shares in an Issue that is oversubscribed shall be subject to the reservation for small individual applicants as described below
 - a) Minimum fifty percent to retail individual investors; and
 - b) Remaining to Individual applicants other than retail individual investors; and Other investors including corporate bodies or institutions, irrespective of the number of specified securities applied for;

Bansal Roofing Products Limited

c) The unsubscribed portion in either of the categories specified in (a) or (b) above may be made available for allocation to the applicants in the other category, if so required.

“If the retail individual investor category is entitled to more than fifty percent on proportionate basis, the retail individual investors shall be allocated that higher percentage.”

The Executive Director / Managing Director of the SME Exchange in addition to LM and Registrar to the Public Issue shall be responsible to ensure that the basis of allotment is finalized in a fair and proper manner in accordance with the SEBI (ICDR) Regulations.

Allotment and Issuance of Allotment Advice

- a. Upon approval of the Basis of Allotment by the SME Exchange, the Board of Directors of our Company shall pass a Board Resolution within 9 (nine) Working Days, allotting the equity shares to the successful Applicants. The Registrar to the Issue shall upload the allotment details on its website and our Company and Registrar will proceed effect the corporate action for crediting the Equity Shares to the demat account of the allottees. Our Company and Registrar shall endeavour to give instructions to Depositories for credit of shares to successful allottees within 9 (nine) Working Days of Issue Closing Date and receive confirmation of Demat credit from Depositories within 11 (eleven) Working Days of Issue Closing Date.
- b. In the event of under subscription in the Issue and the underwriting being called upon to fulfil the obligations under the Underwriting Agreement, our Company shall make the allotments after achieving the Minimum Subscription within the time specified.
- c. Pursuant to confirmation of corporate actions with respect to Allotment of Equity Shares, the Registrar to the Issue will dispatch Allotment Advice to the Applicants who have been Allotted Equity Shares in the Issue. In their own interest, Allottees should verify the Allotment Advice received with their demat credits and bring discrepancy if any to the notice to the Registrar and / or to our Compliance Officer.
- d. The dispatch of Allotment Advice shall be deemed a valid, binding and irrevocable contract for the Applicant.

Investors are advised to instruct their Depository Participant to accept the Equity Shares that may be allotted to them pursuant to the Issue.

REFUNDS

In case of Applicants receiving refunds through electronic transfer of funds, delivery of refund orders/ allocation advice/ CANs may get delayed if the same once sent to the address obtained from the depositories are returned undelivered. In such an event, the address and other details given by the Applicant in the Application Form would be used only to ensure dispatch of refund order Please note that any such delay shall be at the Applicants sole risk and neither our Company, the Registrar, Escrow Collection Bank(s) nor the LM shall be liable to compensate the Applicant for any losses caused to the Applicant due to any such delay or liable to pay any interest for such delay.

In case no corresponding record is available with the Depositories, which matches three parameters, namely, names of the Applicants (including the order of names of joint holders), the Depository Participant's identity (DP ID) and the beneficiary's identity, then such Applications are liable to be rejected.

Our Company in its absolute discretion, reserves the right to permit the holder of the power of attorney to request the Registrar that for the purpose of printing particulars on the refund order and mailing of the refund order/ CANs/ allocation advice/ refunds through electronic transfer of funds, the Demographic Details given on the Application Form should be used (and not those obtained from the Depository of the Applicant). In such cases, the Registrar shall use Demographic Details as given in the Application Form instead of those obtained from the Depositories.

Refunds, dividends and other distributions, if any, will be payable in Indian Rupees only and net of bank charges and/ or commission. In case of Applicants who remit money through Indian Rupee drafts purchased abroad, such payments in Indian Rupees will be converted into US Dollars or any other freely convertible currency as may be permitted by the RBI at the rate of exchange prevailing at the time of remittance and will be dispatched by registered post or if the Applicants so desire, will be credited to their NRE accounts, details of which should be furnished in the space provided for this purpose in the Application Form. Our Company will not be responsible for loss, if any, incurred by the Applicant on account of conversion of foreign currency.

As per the RBI regulations, OCBs are not permitted to participate in the Issue.

There is no reservation for Non-Residents, NRIs, FIIs & FVCFs and all Non-Residents, NRIs, FIIs & FVCFs will be treated on the same basis with other categories for the purpose of allocation.

Payment of Refund

Applicants must note that on the basis of name of the Applicants, Depository Participant's name, DP ID, Beneficiary Account number provided by them in the Application Form, the Registrar will obtain, from the Depositories, the Applicants' bank account details, including the nine digit Magnetic Ink Character Recognition ("**MICR**") code as appearing on a cheque leaf. Hence Applicants are advised to immediately update their bank account details as appearing on the records of the Depository Participant. Please note that failure to do so could result in delays in dispatch of refund order or refunds through electronic transfer of funds, as applicable, and any such delay shall be at the Applicants' sole risk and neither the Company, the Registrar, Escrow Collection Bank(s), Bankers to the Issue nor the LM shall be liable to compensate the Applicants for any losses caused to the Applicant due to any such delay or liable to pay any interest for such delay.

Mode of making refunds

The payment of refund, if any, would be done through various modes as given hereunder:

- 1) **NECS (National Electronic Clearing System)** - Payment of refund would be done through NECS for applicants having an account at any of the centres where such facility has been made available specified by the RBI. This mode of payment of refunds would be subject to availability of complete bank account details including the MICR code from the Depositories.
- 2) **Direct Credit** - Applicants having bank accounts with the Refund Banker(s), as mentioned in the Application Form, shall be eligible to receive refunds through direct credit. Charges, if any, levied by the Refund Bank(s) for the same would be borne by the Company.
- 3) **RTGS (Real Time Gross Settlement)** - Applicants having a bank account at any of the centres where such facility has been made available and whose refund amount exceeds ₹2.00 Lakhs, have the option to receive refund through RTGS. Such eligible applicants who indicate their preference to receive refund through RTGS are required to provide the IFSC code in the application Form. In the event the same is not provided, refund shall be made through NECS. Charges, if any, levied by the Refund Bank(s) for the same would be borne by the Company. Charges, if any, levied by the applicant's bank receiving the credit would be borne by the applicant.
- 4) **NEFT (National Electronic Fund Transfer)** - Payment of refund shall be undertaken through NEFT wherever the applicants' bank has been assigned the Indian Financial System Code (IFSC), which can be linked to a Magnetic Ink Character Recognition (MICR), if any, available to that particular bank branch. IFSC Code will be obtained from the website of RBI as on a date immediately prior to the date of payment of refund, duly mapped with MICR number. Wherever the applicants have registered their nine digit MICR number and their bank account number while opening and operating the demat account, the same will be duly mapped with the IFSC Code of that particular bank branch and the payment of refund will be made to the applicants through this method. The process flow in respect of refunds by way of NEFT is at an evolving stage and hence use of NEFT is subject to operational feasibility, cost and process efficiency.
- 5) For all other applicants, including those who have not updated their bank particulars with the MICR code, the refund orders will be through Speed Post/ Registered Post. Such refunds will be made by cheques, pay orders or demand drafts drawn on the Escrow Collection Banks and payable at par at places where Applications are received. Bank charges, if any, for cashing such cheques, pay orders or demand drafts at other centers will be payable by the Applicants.

Mode of making refunds for ASBA Applicants

In case of ASBA Applicants, the Registrar shall instruct the relevant SCSB to unblock the funds in the relevant ASBA Account to the extent of the Application Amount specified in the Application Forms for withdrawn, rejected or unsuccessful or partially successful ASBA Applications within 9 (nine) working days from the Issue Closing Date.

DISPOSAL OF APPLICATION AND APPLICATION MONEY

Our Company shall ensure the dispatch of Allotment advice, refund orders (except for Applicants who receive refunds through electronic transfer of funds) and give benefit to the beneficiary account with Depository Participants and submit the documents pertaining to the Allotment to the Stock Exchange within 2 (two) Working Days of date of Allotment of Equity Shares.

In case of applicants who receive refunds through NECS, direct credit or RTGS, the refund instructions will be given to the clearing system within 15 (fifteen) Days from the Issue Closing Date. A suitable communication shall be sent to the Applicants receiving refunds through this mode within 15 (fifteen) Days of Issue Closing Date, giving details of the bank where refunds shall be credited along with amount and expected date of electronic credit of refund.

Our Company shall use best efforts to ensure that all steps for completion of the necessary formalities for listing and commencement of trading at SME Exchange where the Equity Shares are proposed to be listed are taken within 7 (seven) Working Days of Allotment.

INTEREST IN CASE OF DELAY IN DESPATCH OF ALLOTMENT LETTERS/REFUND ORDERS IN CASE OF PUBLIC ISSUES

In accordance with the Companies Act, the requirements of the Stock Exchange and the SEBI (ICDR) Regulations, our Company further undertakes that:

- 1) Allotment of Equity Shares shall be made within 15 (fifteen) Days of the Issue Closing Date;
- 2) Dispatch of refund orders or in a case where the refund or portion thereof is made in electronic manner, the refund instructions are given to the clearing system within 15 (fifteen) Days of the Issue Closing Date would be ensured; and
- 3) The Company shall pay interest at 15% p.a. for any delay beyond the 15 (fifteen) Days time period as mentioned above, if Allotment is not made and refund orders are not dispatched or if, in a case where the refund or portion thereof is made in electronic manner, the refund instructions have not been given to the clearing system in the disclosed manner and/or demat credits are not made to investors within the 15 (fifteen) Days time.

UNDERTAKINGS BY OUR COMPANY

The Company undertakes the following:

1. that the complaints received in respect of this Issue shall be attended to by us expeditiously and satisfactorily;
2. that all steps will be taken for the completion of the necessary formalities for listing and commencement of trading at the Stock Exchange where the Equity Shares are proposed to be listed within 7 (seven) working days of finalization of the basis of Allotment;
3. that funds required for making refunds to unsuccessful applicants as per the mode(s) disclosed shall be made available to the Registrar to the Issue by the Issuer;
4. that where refunds are made through electronic transfer of funds, a suitable communication shall be sent to the applicant within 15 (fifteen) days of the Issue Closing Date, as the case may be, giving details of the bank where refunds shall be credited along with amount and expected date of electronic credit of refund;
5. that the certificate of the securities / refund orders to the non-resident Indians shall be dispatched within specified time; and
6. that no further issue of Equity Shares shall be made till the Equity Shares offered through this Prospectus are listed or until the Application monies are refunded on account of non-listing, under subscription etc.
7. that The Company shall not have recourse to the Issue proceeds until the approval for trading of the Equity Shares from the Stock Exchange where listing is sought has been received and

Bansal Roofing Products Limited

8. that Adequate arrangements shall be made to collect all Applications Supported by Blocked Amount and to consider them similar to non-ASBA applications while finalizing the basis of allotment.

WITHDRAWAL OF THE ISSUE

Our Company, in consultation with the LM, reserves the right not to proceed with the Issue at any time before the Issue Opening Date without assigning any reason thereof.

If our Company withdraws the Issue anytime after the Issue Opening Date but before the allotment of Equity Shares, our Company will issue a public notice within 2 (two) working days of the Issue Closing Date, providing reasons for not proceeding with the Issue. The notice of withdrawal will be issued in the same newspapers where the pre-Issue advertisements have appeared and the Stock Exchange will also be informed promptly. The LM, through the Registrar to the Issue, will instruct the SCSBs to unblock the ASBA Accounts within 1 (one) working Day from the day of receipt of such instruction.

If our Company withdraws the Issue after the Issue Closing Date and subsequently decides to undertake a public offering of Equity Shares, our Company will file a fresh Prospectus with the stock exchange where the Equity Shares may be proposed to be listed.

Notwithstanding the foregoing, the Issue is subject to obtaining (i) the final listing and trading approvals of the Stock Exchange with respect to the Equity Shares offered through the Prospectus, which our Company will apply for only after Allotment; and (ii) the final RoC approval of the Prospectus.

UTILIZATION OF ISSUE PROCEEDS

Our Board certifies that:

1. All monies received out of the Issue shall be credited/ transferred to a separate bank account other than the bank account referred to in sub section (3) of Section 40 of the Companies Act 2013;
2. Details of all monies utilized out of the Issue shall be disclosed, and continue to be disclosed till the time any part of the issue proceeds remains unutilized, under an appropriate head in our balance sheet indicating the purpose for which such monies have been utilized;
3. Details of all unutilized monies out of the Issue, if any shall be disclosed under the appropriate head in the balance sheet indicating the form in which such unutilized monies have been invested and
4. Our Company shall comply with the requirements of Clause 52 of the SME Listing Agreement in relation to the disclosure and monitoring of the utilization of the proceeds of the Issue.
5. Our Company shall not have recourse to the Issue Proceeds until the approval for listing and trading of the Equity Shares from the Stock Exchange where listing is sought has been received.

EQUITY SHARES IN DEMATERIALIZED FORM WITH NSDL OR CDSL

To enable all shareholders of the Company to have their shareholding in electronic form, the Company had signed the following tripartite agreements with the Depositories and the Registrar and Share Transfer Agent:

- (a) Agreement dated March 27, 2014 between NSDL, the Company and the Registrar to the Issue;
- (b) Agreement dated March 18, 2014 between CDSL, the Company and the Registrar to the Issue;

Our Company's shares bear an ISIN No. INE319Q01012

1. An Applicant applying for Equity Shares must have at least one beneficiary account with either of the Depository Participants of either NSDL or CDSL prior to making the Application.
2. The Applicant must necessarily fill in the details (including the Beneficiary Account Number and Depository Participant's identification number) appearing in the Application Form or Revision Form.
3. Allotment to a successful Applicant will be credited in electronic form directly to the beneficiary account (with the Depository Participant) of the Applicant.

Bansal Roofing Products Limited

4. Names in the Application Form or Revision Form should be identical to those appearing in the account details in the Depository. In case of joint holders, the names should necessarily be in the same sequence as they appear in the account details in the Depository.
5. If incomplete or incorrect details are given under the heading 'Applicants Depository Account Details' in the Application Form or Revision Form, it is liable to be rejected.
6. The Applicant is responsible for the correctness of his or her Demographic Details given in the Application Form vis a vis those with his or her Depository Participant.
7. Equity Shares in electronic form can be traded only on the stock exchanges having electronic connectivity with NSDL and CDSL. The Stock Exchange where our Equity Shares are proposed to be listed have electronic connectivity with CDSL and NSDL.
8. The trading of the Equity Shares of our Company would be in dematerialized form only for all investors.

Communications

All future communications in connection with Applications made in this Issue should be addressed to the Registrar to the Issue quoting the full name of the sole or First Applicant, Application Form number, Applicants Depository Account Details, number of Equity Shares applied for, date of Application form, name and address of the Banker to the Issue where the Application was submitted and cheque or draft number and issuing bank thereof and a copy of the acknowledgement slip.

Investors can contact the Compliance Officer or the Registrar to the Issue in case of any pre Issue or post Issue related problems such as non-receipt of letters of allotment, credit of allotted shares in the respective beneficiary accounts, refund orders etc.

RESTRICTIONS ON FOREIGN OWNERSHIP OF INDIAN SECURITIES

Foreign investment in Indian securities is regulated primarily by the FEMA and the policy prescribed by the Department of Industrial Policy and Promotion, Government of India through Consolidated FDI Policy Circular of 2014 with effect from April 17, 2014 (“FDI Policy”). While the Industrial Policy, 1991 prescribes the limits and the conditions subject to which foreign investment can be made in different sectors of the Indian economy, FEMA regulates the precise manner in which such investment may be made. Under the Industrial Policy, unless specifically restricted, foreign investment is freely permitted in all sectors of Indian economy up to any extent and without any prior approvals, but the foreign investor is required to follow certain prescribed procedures for making such investment. The government bodies responsible for granting foreign investment approvals are FIPB and the RBI.

The Government has from time to time made policy pronouncements on FDI through press notes and press releases. The Consolidated FDI Policy issued by the Department of Industrial Policy and Promotion under Ministry of Commerce and Industry, GoI (“DIPP”) by Circular of 2014, with effect from April 17, 2014 (“Consolidated FDI Policy”), consolidates and supersedes all previous press notes, press releases and clarifications on FDI issued by the DIPP and is currently applicable to all FDI matter.

In terms of the Consolidated FDI policy (effective from April 17, 2014), issued by the Department of Industrial Policy and Promotion, 100% foreign direct investment in the Company is permitted.

Subscription by foreign investors (NRIs/FIIs)

FIIs are permitted to subscribe to Equity Shares of an Indian Company in a public offer without the prior approval of the RBI, so long as the price of the Equity Shares to be issued is not less than the price at which the Equity Shares are issued to residents.

The transfer of shares between an Indian resident and a non-resident does not require the prior approval of the FIPB or the RBI, provided that (i) the activities of the investee company are under the automatic route under the FDI Policy and transfer does not attract the provisions of the SEBI (Substantial Acquisition of Shares and Takeovers) Regulations, 2011 (ii) the non-resident shareholding is within the sectoral limits under the FDI Policy; and (iii) the pricing is in accordance with the guidelines prescribed by SEBI/ RBI.

Representation from the Applicants

No person shall make an Application in the Issue, unless such person is eligible to acquire Equity Shares of our Company in accordance with applicable laws, rules, regulations, guidelines and approvals.

Investors that make Application under the Issue will be required to confirm and will be deemed to have represented to our Company, the Underwriters, and their respective directors, officers, agents, affiliates and representatives, as applicable, that they are eligible under all applicable laws, rules, regulations, guidelines and approvals to acquire Equity Shares of our Company and will not offer, sell, pledge or transfer the Equity Shares of our Company to any person who is not eligible under applicable laws, rules, regulations, guidelines and approvals to acquire Equity Shares of our Company. Our Company, the Underwriters and their respective directors, officers, agents, affiliates and representatives, as applicable, accept no responsibility or liability for advising any investor on whether such investor is eligible to acquire Equity Shares of our Company.

There is no reservation for Non Residents, NRIs, FIIs, foreign venture capital funds, multi-lateral and bilateral development financial institutions and any other foreign investor. All Non Residents, NRIs, FIIs and foreign venture capital funds, multi-lateral and bilateral development financial institutions and any other foreign investor applicants will be treated on the same basis with other categories for the purpose of allocation.

As per the existing policy of the Government of India, OCBs also cannot participate in any Public Issue.

The Equity Shares have not been and will not be registered under the Securities Act or any state securities laws in the United States and may not be offered or sold within the United States or to, or for the account or benefit of, “U.S. persons” (as defined in Regulation S promulgated under the Securities Act), except pursuant to an exemption from, or in a transaction not subject to, the registration requirements of the Securities Act. Accordingly, the Equity Shares are only being offered and sold outside the United States to certain persons in offshore transactions in compliance with Regulation S under the Securities Act.

Bansal Roofing Products Limited

Our Company, LM and the Issue Management Team will is not making any selling efforts in any jurisdiction outside India.

The Equity Shares have not been and will not be registered, listed or otherwise qualified in any other jurisdiction outside India and may not be offered or sold, and applications may not be made by persons in any such jurisdiction, except in compliance with the applicable laws of such jurisdiction.

The above information is given for the benefit of the Applicants. The Company and the LM are not liable for any amendments or modification or changes in applicable laws or regulations, which may occur after the date of this Prospectus. Applicants are advised to make their independent investigations and ensure that the number of Equity Shares applied for do not exceed the applicable limits under laws or regulations.

SECTION VIII - MAIN PROVISIONS OF ARTICLES OF ASSOCIATION OF OUR COMPANY

Pursuant to Schedule II of the Companies Act, and the SEBI ICDR Regulations, the Main provisions of the Articles of Association relating to voting rights, dividend, lien, forfeiture, restrictions on transfer and Transmission of equity shares or debentures, their consolidation or splitting are as provided below. Each provision below is numbered as per the corresponding article number in the articles of association and defined terms herein have the meaning given to them in the Articles of Association.

SHARE CAPITAL AND VARIATION OF RIGHTS

5. (a) The Authorised Share Capital of the Company shall be as per Clause V of the Memorandum of Association of the Company with rights to alter the same in whatever way as deemed fit by the Company. The Company may increase the Authorised Capital which may consist of Equity and / or Preference Shares as the Company in General Meeting may determine in accordance with the law for the time being in force relating to Companies with power to increase or reduce such capital from time to time in accordance with the Regulations of the Company and the legislative provisions for the time being in force in this behalf and with power to divide the shares in the Capital for the time being into Equity Share Capital or Preference Share Capital and to attach thereto respectively any preferential, qualified or special rights, privileges or conditions and to vary, modify and abrogate the same in such manner as may be determined by or in accordance with these presents.
- (b) Subject to the rights of the holders of any other shares entitled by the terms of issue to preferential repayment over the equity shares in the event of winding up of the Company, the holders of the equity shares shall be entitled to be repaid the amounts of capital paid up or credited as paid up on such equity shares and all surplus assets thereafter shall belong to the holders of the equity shares in proportion to the amount paid up or credited as paid up on such equity shares respectively at the commencement of the winding up.

INCREASE REDUCTION AND ALTERATION OF CAPITAL

6. The Company may from time to time in General Meeting increase its Share Capital by the issue of new shares of such amounts as it thinks expedient.

On what conditions the new shares may be issued

- (a) Subject to the provisions of sections 80, 81 and 85 to 90 of the Companies Act, 1956, and subject to the provisions of section 44 and 45 of the Companies Act, 2013, the new shares shall be issued upon such terms and conditions and with such rights and privileges annexed thereto by the General Meeting creating the same as shall be directed and if no direction be given as the Directors shall determine and in particular such shares may be issued subject to the provisions of the said sections with a preferential or qualified right to dividends and in distribution of assets of the Company and subject to the provisions of the said sections with special or without any right of voting and subject to the provisions of Section 80 of the Act any preference shares may be issued on the terms that they are or at the option of the Company are liable to be redeemed.

Further issue of Shares

- (b) Where at any time after the expiry of two years from the formation of a Company or at any time after the expiry of one year from the allotment of shares in that Company made for the first time after its formation, whichever is earlier, it is proposed to increase the subscribed capital of the Company by allotment of further shares, then
- (i) such further shares shall be offered to the persons who at the date of offer, are holders of the equity - shares of the Company, in proportion, as nearly as circumstances admit, to the Capital paid up on those shares at that date.
- (ii) the offer aforesaid shall be made by a notice specifying the number of shares offered and limiting a time not being less than fifteen days from the date of the offer within which the offer, if not accepted, will be deemed to have been declined.
- (iii) unless the articles of the company otherwise provide, the offer aforesaid shall be deemed to include a right exercisable by the person concerned to renounce the shares offered to him or any of them in favour of any other person; and the notice referred to in clause (b) shall contain a statement of this right.
- (iv) after the expiry of the time specified in the notice aforesaid or on receipt of earlier intimation from the person to whom such notice is given that he declines to accept the shares offered, the Board of directors may dispose of them in such manner as they think most beneficial to the Company.

- (c) Notwithstanding anything contained in the preceding sub-clause (1), the further shares aforesaid may be offered to any persons [whether or not those persons include the persons referred to in clause sub-clause (1)] in any manner whatsoever:-
 - (i) if a special resolution to that effect is passed by the company in general meeting, or
 - (ii) where no such special resolution is passed if the votes cast (whether on a show of hands or on a poll, as the case may be) in favour of the proposal contained in the resolution moved in that General Meeting (including the casting vote, if any, of the Chairman) by members who, being entitled so to do, vote in person, or where proxies are allowed, by proxy, exceed the votes, if any, cast against the proposal by members so entitled and voting and the Central Government is satisfied, on an application made by the Board of Directors in this behalf, that the proposal is most beneficial to the Company.
- (d) Nothing in clause (c) above shall be deemed -
 - (i) to extend the time within which the offer should be accepted, or
 - (ii) to authorise any person to exercise the right of renunciation for a second time, on the ground that the person in whose favour the renunciation was first made has declined to take the shares comprised in the renunciation.
- (e) Nothing in this article shall apply -
to the increase of the subscribed capital of the company caused by the exercise of an option attached to the debentures issued or loans raised by the company -
 - (i) to convert such debentures or loans into shares in the company, or
 - (ii) to subscribe for shares in the company;
Provided that the terms of issue of such debentures or the terms of such loans includes a term providing for such option and such term:
 - (a) either has been approved by the Central Government before the issue of debentures or the raising of the loans, or is in conformity with the rules , if any, made by that Government in this behalf; and
 - (b) in the case of debentures or loans other than debentures issued to, or loans obtained from, the Government or any institution specified by the Central Government in this behalf, has also been approved by a special resolution passed by the company in general meeting before the issue of the debentures or the raising of the loans.

Same as Original Capital

- (f) Except so far as otherwise provided by the conditions of issue or by these presents, any Capital raised by the creation of new shares shall be considered as part of the original Capital and shall be subject to the provisions herein contained with reference to the payment of calls, installments, transfers, transmission, forfeiture, lien, surrender, voting and otherwise.

Reduction of Capital

- 9. The Company may from time to time by special resolution, subject to confirmation by the Court and subject to the provisions of Sections 78, 80 and 100 to 104 of the Companies Act, 1956 and, reduce its Share Capital and any Capital Redemption Reserve Account or Premium Account in any manner for the time being authorised by law and in particular without prejudice to the generality of the foregoing power may be:
 - (a) extinguishing or reducing the liability on any of its shares in respect of Share Capital not paid up;
 - (b) either with or without extinguishing or reducing liability on any of its shares, cancel paid up Share Capital which is lost or is unrepresented by available assets; or
 - (c) either with or without extinguishing or reducing liability on any of its shares, pay off any paid up Share Capital which is in excess of the wants of the Company; and may, if and so far as is necessary, alter its Memorandum, by reducing the amount of its Share Capital and of its shares accordingly.

Division, Sub-Division, Consolidation, Conversion and Cancellation of Shares

- 10. Subject to the provisions of Section 94 of the Companies Act, 1956 the Company in General Meeting may by an ordinary resolution alter the conditions of its Memorandum as follows, that is to say it may:
 - (a) consolidate and divide all or any of its Share Capital into shares of larger amount than its existing shares;
 - (b) sub-divide its shares or any of them into shares of smaller amount than originally fixed by the Memorandum subject nevertheless to the provisions of the Act in that behalf and so however that in the sub-division the proportion between the amount paid and the amount if any, unpaid on each reduced share shall be the same as it was in the case of the share from which the reduced share is derived and so that as between the holders of the shares resulting from such sub-division one or more of such shares may, subject to the provisions of the Act, be given any preference or advantage over the others or any other such shares;
 - (c) convert, all or any of its fully paid up shares into stock, and re-convert that stock into fully paid up shares of any denomination;

- (d) cancel, shares which at the date of such General Meeting have not been taken or agreed to be taken by any person, and diminish the amount of its Share Capital by the amount of the shares so cancelled.

Notice to Register of Consolidation of Share Capital, Conversion of shares into stocks etc.

11. (a) If the Company has :
- (i) consolidated and divided its Share Capital into shares of larger amount than its existing shares;
 - (ii) converted any shares into stock;
 - (iii) reconverted any stock into shares;
 - (iv) sub-divided its share or any of them;
 - (v) redeemed any redeemable preference shares; or
 - (vi) cancelled any shares otherwise than in connection with a reduction of Share Capital under Sections 100 to 104 of the Companies Act,1956
- the Company shall within one month after doing so, give notice thereof to the Registrar specifying as the case may be, the shares consolidated, divided, converted, sub-divided, redeemed or cancelled or the stocks reconverted.
- (b) The Company shall thereupon request the Registrar to record the notice and make any alterations which may be necessary in the Company's Memorandum or Articles or both.

Modifications of rights

12. If at any time the Share Capital, by reason of the issue of Preference Shares or otherwise, is divided into different classes of shares, all or any of the rights and privileges attached to any class (unless otherwise provided by the terms of issue of the shares of that class) may, subject to the provisions of Sections 106 and 107 of the Act and whether or not the Company is being wound up, be varied, modified, commuted, affected or abrogated with the consent in writing of the holders of three-fourths in nominal value of the issued shares of that class or with the sanction of a Special Resolution passed at a separate General Meeting of the holders of the shares of that class. This Article shall not derogate from any power which the Company would have if this Article were omitted. The provisions of these Articles relating to General Meetings shall mutatis mutandis apply to every such separate meeting but so that if at any adjourned meeting of such holders a quorum as defined in Article 102 is not present, those persons who are present shall be quorum.

SHARES AND CERTIFICATES

Issue of further Shares not to affect right of existing share holders

13. The rights or privileges conferred upon the holders of the shares of any class issued with preference or other rights, shall not unless otherwise be deemed to be varied or modified or affected by the creation or issue of further shares ranking pari passu therewith.

Provisions of Sections 85 and 86 of the Companies Act, 1956 to apply

14. The provisions of Sections 85 and 86 of the Act in so far as the same may be applicable shall be observed by the Company.

Register of Members and Debenture holders

15. (a) The Company shall cause to be kept a Register of Members and an Index of Members in accordance with Sections 150 and 151 of the Act and Register and Index of Debenture holders in accordance with Section 152 of the Companies Act,1956. The Company may also keep a foreign Register of Members and Debenture holders in accordance with Section 157 of the Act.
- (b) The Company shall also comply with the provisions of Sections 159 and 161 of the Companies Act,1956 as to filling of Annual Returns.
- (c) The Company shall duly comply with the provisions of Section 163 of the Act in regard to keeping of the Registers, Indexes, Copies of Annual Returns and giving inspection thereof and furnishing copies thereof.

Commencement of business

16. The Company shall comply with the provisions of Section 149 of the Act.

Restriction on allotment

17. The Board shall observe the restriction as to allotment of shares to the public contained in Chapter III Part I Section 39 (to the extent notified) of the Companies Act, 2013 and Sections 69 and 70 of the Companies Act,1956 and shall cause to be made the return as to allotment provided for in Section 75 of the Act.

Shares to be numbered progressively and no shares to be subdivided

18. The shares in the Capital shall be numbered progressively according to the several denominations and except in the manner hereinbefore mentioned no share shall be subdivided. Every forfeited or surrendered share shall continue to bear the number by which the same was originally distinguished.

Shares at the disposal of the Directors

19. Subject to the provisions of Section 81 of the Companies Act, 1956 and these Articles the shares in the Capital of the Company for the time being shall be under the control of the Directors who may issue, allot or otherwise dispose of the same or any of them to such persons, in such proportion and on such terms and conditions and either at a premium or at par or (subject to compliance with the provisions of Section 79 of the Act) at a discount and at such time as they may from time to time think fit and with the sanction of the Company in General Meeting to give to any person the option to call for any shares either at par or at a premium during such time and for such option to call for any shares either at par or at a premium during such time and for such consideration as the Directors think fit, and may issue and allot shares in the Capital of the Company on payment in full or part for any property sold and transferred or for services rendered to the Company in the conduct of its business and any shares which may be so allotted may be issued as fully paid up shares and if so issued, shall be deemed to be fully paid shares.

Every share transferable etc.

20. (i) The shares or other interest of any member in the Company shall be a movable property, transferable in the manner provided by the Articles.
(ii) Each share in the Company shall be distinguished by its appropriate number.
(iii) A Certificate under the Common Seal of the Company, specifying any shares held by any member shall be prima facie evidence of the title of the member of such shares.

Application of premium received on issue of shares

21. (a) Where the Company issues shares at a premium, whether for cash or otherwise, a sum equal to the aggregate amount or value of the premium on those shares shall be transferred to an account to be called "the Share Premium Account" and the provisions of the Act relating to the reduction of the Share Capital of the Company shall except as provided in this Article, apply as if the Share Premium Account were paid-up Share Capital of the Company.
(b) The Share Premium Account may, notwithstanding, anything in clause (a) above, be applied by the Company.
(i) in paying up unissued shares of the Company to be issued to members of the Company as fully paid bonus shares;
(ii) in writing off the preliminary expenses of the Company;
(iii) in writing off the expenses of, or the commission paid or discount allowed on, any issue of shares or debentures of the Company; or
(iv) in providing for the premium payable on the redemption of any redeemable preference shares or of any debenture of the Company.

Fractional shares

22. If and whenever, as the result of issue of new or further shares or any consolidation or sub-division of shares, any member becomes entitled to any fractional share, the same shall be rounded off to nearest one and allotment of shares shall be made accordingly.

‘Buy back of Shares’

- 22A. Notwithstanding anything contained in any other Article of the Articles of Association, but subject to the provisions of Section 70 (to the extent notified) of the Companies Act, 2013 and the provisions of Section 77 A and 77 B of the Act and Securities & Exchange Board of India (Buy back of Securities) Regulations 1998 as may be in force at any time and from time to time, the Company may acquire, purchase, own, resell any of its own fully/partly paid or redeemable Preference Shares or Equity Shares and any other security as may be specified under the Act, Rules and regulations from time to time and may make payment thereof out of funds at its disposal or in any manner as may be permissible or in respect of such acquisition/purchase on such terms and conditions and at such time or times in one or more installments as the Board may in its discretion decide and deem fit. Such Shares which are so bought back by the Company may either be extinguished and destroyed or reissued as may be permitted under the Act or the Regulations as may be in force at the relevant time subject to such terms and conditions as may be decided by the Board and subject further to the rules & regulations governing such issue.

Acceptance of Shares

23. An application signed by or on behalf of an applicant for shares in the Company, followed by an allotment of any shares therein shall be an acceptance of shares within the meaning of these Articles and every person who thus or otherwise accepts any shares and whose name is on the Register of Members shall for the purpose of these Articles be a member. The Director shall comply with the provisions of Sections 69, 70, 71, 72 and 73 of the Companies Act, 1956 and Section 39 & 40 of the Companies Act, 2013 in so far as they are applicable.

Deposits and calls etc. to be a debt payable immediately

24. The money (if any) which the Board shall, on the allotment of any shares being made by them, require or direct to be paid by way of deposit, call or otherwise in respect of any shares allotted by them, immediately, on the insertion of the name of the allottee in the Register of Members as the name of the holder of such shares, become a debt, due to and recoverable by the Company from the allottee thereof, and shall be paid by him accordingly.

Trusts not recognized

25. Save as herein provided, the Company shall be entitled to treat the person whose name appears on the Register of Members as the holders of any share as the absolute owner thereof, and accordingly shall not (except as ordered by a Court of Competent jurisdiction or as by law required) be bound to recognize any benami, trust of equity or equitable, contingent, future, or partial or other claim or claims or right to or interest in such share on the part of any other person whether or not it shall have express or implied notice thereof and the provisions of Section 153 of the Act shall apply.

Issue of Certificates of Shares to be governed by Section 84 of the Act etc.

26. (a) The issue of certificates of shares or of duplicate or renewal of certificates of Shares shall be governed by the provisions of Section 84 and other provisions of the Companies Act, 1956 as may be applicable and by the Rules or notifications or orders, if any, which may be prescribed or made by competent authority under the Act or Rules or any other law. The Directors may also comply with the provisions of such rules or regulations of any Stock Exchange where the shares of the Company may be listed for the time being.

Certificate of Shares

(b) The Certificate of title to shares shall be issued under the Seal of the Company and shall be signed by such Directors or Officers or other authorised persons as may be prescribed by the Rules made under the Act from time to time and subject thereto shall be signed in such manner and by such persons as the Directors may determine from time to time.

(c) The Company shall comply with all rules and regulations and other directions which may be made by any competent authority under Section 84 of the Act.

Limitation of time for issue of certificate

27. (a) Every member shall be entitled, without payment, to one or more Certificate in marketable lots, for all the shares of each class or denomination registered in his name, or if the Directors so approve (upon paying such fee as the Directors may from time to time determine) to several certificates, each for one or more of such shares and the Company shall complete and have ready for delivery such Certificates within three months from the date of allotment, unless the conditions of issue thereof otherwise provide or within two months of the receipt of application of registration of transfer transmission, sub-division, consolidation or renewal of any of its shares as the case may be. Every certificate of shares shall be under the Seal of the Company and shall specify the number and distinctive numbers of the shares in respect of which it is issued and the amount paid up thereon and shall be in such form as the Directors may prescribe or approve provided that in respect of a Share or Shares held jointly by several persons, the Company shall not be borne to issue more than one certificate and delivery of a certificate of shares to one of several joint holders shall be sufficient delivery to all such holders.

(b) The Company shall not entertain any application for split of share / debenture certificate for less than 10 (Ten) Equity Shares / 10 (Ten) debentures (all relating to the same series) in market lots as the case may be.

Provided however this restriction shall not apply to an application made by the existing members or debenture holders for split of share / debenture certificates with a view to make an odd lot holding into a marketable lot subject to verification by the Company.

(c) Notwithstanding anything contained in Clause (a) above, the Directors shall, however, comply with such requirements of the Stock Exchange where Shares of the Company may be listed or such requirements of any rules made under the Act or such requirements of the Securities Contracts (Regulations) Act, 1956 as may be applicable.

Issue of new Certificate in place of one defaced, lost or destroyed

28. If any certificate be worn out, defaced, mutilated or torn or if there be no further space on the back thereof for endorsement of transfer, then upon production and surrender thereof to the Company, a new certificate may be issued in lieu thereof, and if any Certificate be lost or destroyed then upon proof thereof to the satisfaction of the

Company and on execution of such indemnity as the Company deem adequate, being given, a new Certificate in lieu thereof shall be given to the party entitled to such lost or destroyed Certificate. Every Certificate under these Articles shall be issued without payment of fees if the Directors so decide, or on payment of such fees (not exceeding Re. 2/- for each Certificate) as the Directors shall prescribe. Provided that no fee shall be charged for issue of new certificates in replacement of those which are old, defaced or worn out or where there is no further space on the back thereof for endorsement of transfer.

Provided that notwithstanding what is stated above the Directors shall comply with such Rules or Regulations or requirements of any Stock Exchange or the Rules made under the Act or the Rules made under Securities Contracts (Regulations) Act, 1956 or any other Act, or Rules applicable in this behalf.

29. The provisions of these Articles shall mutatis mutandis apply to debentures of the Company.

UNDERWRITING COMMISSION AND BROKERAGE

Power to pay certain commission and prohibition of payment of all other commission, discounts etc.

30. (A) The Company may pay a commission to any person in consideration of:
- (i) his subscribing or agreeing to subscribe whether absolutely or conditionally, for any shares in or debentures of the Company, subject to the restrictions specified in sub-section (4A) of Section 76 of the Companies Act, 1956 and Section 40 (to the extent notified) of the Companies Act, 2013 or
 - (ii) his procuring or agreeing to procure subscriptions, whether absolute or conditional for any shares in or debentures of the Company, if the following conditions are fulfilled, namely:
 - (a) the commission paid or agreed to be paid does not exceed in the case of shares, five percent of the price at which the shares are issued and in the case of debentures, two and half percent of the price at which the debentures are issued;
 - (b) the amount or rate percent of the commission paid or agreed to be paid on shares or debentures offered to the public for subscription, is disclosed in the Prospectus, and in the case of shares or debentures not offered to the public for subscription, is disclosed in the Statement in lieu of Prospectus and filed before the payment of the commission with the Registrar, and where a circular or notice, not being a Prospectus inviting subscription for the shares or debentures is issued is also disclosed in that circular or notice;
 - (c) the number of shares or debentures which such persons have agreed for a commission to subscribe, absolutely or conditionally is disclosed in the manner aforesaid and
 - (d) a copy of the contract for the payment of commission is delivered to the Registrar at the time of delivery of the prospectus or the statement in lieu of prospectus for registration.
- (B) Save as aforesaid and save as provided in Section 75 of the Companies Act, 1956 and Section 39 (to the extent notified) of the Companies Act, 2013 the Company shall not allot any of its shares or debentures or apply any of its moneys, either directly or indirectly, in payment of any commission, discount or allowance, to any person in consideration of:
- (i) his subscribing or agreeing to subscribe, whether absolutely or conditionally, for any shares in, or debentures of the Company or;
 - (ii) his procuring or agreeing to procure subscriptions, whether absolutely or conditionally, for any shares in, or debentures of the Company whether the shares, debentures or money be so allotted or applied by, being added to the purchase money of any property acquired by the Company or to the contract price of any work to be executed for the Company or the money be paid out of the nominal purchase money or contract price, or otherwise.
- (C) Nothing in this Article shall affect the power of the Company to pay such brokerage as it has hereto before been lawful for the Company to pay.
- (D) A vendor to, promoter of, or other person who receives payment in shares, debentures or money from the Company shall have and shall be deemed always to have had power to apply any part of the shares, debentures or money so received for payment of any commission, the payment of which, if made directly by the Company would have been legal under Section 76 of the Act.
- (E) The commission may be paid or satisfied (subject to the provisions of the Act and these Articles) in cash, or in shares, debentures or debenture-stocks of the Company.

CALLS

Directors may make Calls

31. The Directors may from time to time and subject to Section 91 of the Companies Act, 1956 and Section 49 (to the extent notified) of Companies Act, 2013 and subject to the terms on which any shares / debentures may have been issued and subject to the conditions of allotment, by a resolution passed at a meeting of the Board (and not by circular resolution) make such calls as they think fit upon the members / debenture holders in respect of all moneys unpaid on the shares / debentures held by them respectively and such members / debenture holders shall pay the amount of every call so made on him to the persons and at the times and place appointed by the Directors. A Call may be made payable by installments. A call may be postponed or revoked as the Board may determine. The option or right to call of shares shall not be given to any of the person except with the sanction of the Issuer in general meeting.

Calls to date from resolution

32. A call shall be deemed to have been made at the time when the resolution of the Directors authorising such Call was passed and may be made payable by members / debenture holders on a subsequent day to be specified by the Directors.

Notice of Call

33. Thirty days notice in writing shall be given by the Company of every calls made payable otherwise than on allotment specifying the time and place of payment provided that before the time of payment of such call, the Directors may by notice in writing to the members / debenture holders revoke the same.

Directors may extend time

34. The Directors may, from time to time, at their discretion, extend the time fixed for the payment of any call, and may extend such time as to all or any of the members / debenture holders who from residence at a distance or other cause, the Directors may deem fairly entitled to such extension, but no member / debenture holder shall be entitled to such extension, save as a matter of grace and favour.

Sums deemed to be Calls

35. Any sum, which by the terms of issue of a share / debenture becomes payable on allotment or at any fixed date whether on account of the nominal value of the share / debenture or by way of premium, shall for the purposes of these Articles be deemed to be a Call duly made and payable on the date on which by the terms of issue the same becomes payable, and in case of non-payment, all the relevant provisions of these Articles as to payment of interest and expenses, forfeiture or otherwise, shall apply as if such sum had become payable by virtue of a Call duly made and notified.

Installments on shares to be duly paid

36. If by the condition of allotment of any shares the whole or part of the amount of issue price thereof shall be payable by installments, every such installment shall, when due, be paid to the Company by the person who, for the time being and from time to time, shall be the registered holder of the share or his legal representative.

Calls on shares of the same class to be made on uniform basis

37. Where any calls for further Share Capital are made on shares, such calls shall be made on a uniform basis on all shares falling under the same class.

Explanation: For the purpose of this provision, shares of the same nominal value on which different amount have been paid up shall not be deemed to fall under the same class.

Liability of joint holders of shares

38. The joint holders of a share shall be severally as well as jointly liable for the payment of all installments and calls due in respect of such shares.

When interest on call or installment payable

39. If the sum payable in respect of any call or installment be not paid on or before the day appointed for payment thereof or any such extension thereof, the holder for the time being or allottee of the share in respect of which a call shall have been made or the installment shall be due, shall pay interest as shall be fixed by the Board from the day appointed for the payment thereof or any such extension thereof to time of actual payment but the Directors may waive payment of such interest wholly or in part.

Restriction of Voting Rights:

No member shall be entitled to exercise any voting rights in respect of any shares registered in his name on which an any calls or other sums presently payable by him have not been paid or in regard to which the company has exercised any right of lien.

Partial payment not to preclude forfeiture

40. Neither a judgement nor a decree in favour of the Company for calls or other moneys due in respect of any shares nor any part payment or satisfaction thereof nor the receipt by the Company of a portion of any money which shall from time to time be due from any member in respect of any shares either by way of principal or interest nor any indulgence granted by the Company in respect of payment of any such money shall preclude the forfeiture of such shares as herein provided.

Proof on trial of suits for money due on shares

41. On the trial or hearing of any action or suit brought by the Company against any member or his legal representative for the recovery of any money claimed to be due to the Company in respect of any shares it shall be sufficient to prove that the name of the member in respect of whose shares the money is sought to be recovered appears in the Register of Members as the holder or one of the holders, at or subsequent to the date at which the money sought to be recovered is alleged to have become due of the shares in respect of which such money is sought to be recovered, and that the resolution making the call is duly recorded in the Minutes Book; and that the notice of such call was duly given to the member or his representatives, sued in pursuance of these presents; and it shall not be necessary to prove the appointment of the Directors who made such calls nor that a quorum of Directors was present at the Board at which any call was made nor that the meeting at which any call was made was duly convened or constituted nor any other matters whatsoever, but the proof of the matters aforesaid shall be conclusive evidence of the debt.

Payment in anticipation of calls may carry Interest

42. (a) The Directors may, if they think fit, subject to the provisions of Section 92 of the Companies Act, 1956 and Section 50 of the Companies Act, 2013 agree to and receive from any member willing to advance the same whole or any part of the money due upon the shares held by him beyond the sum actually called for, and upon the amount so paid or satisfied in advance, or so much thereof as from time to time exceeds the amount of the calls then made upon the shares in respect of which such advance has been made, the Company may pay interest at such rate, as the member paying such sum in advance and the Directors agree upon provided that money paid in advance of calls shall not confer a right to participate in profits or dividends. The Directors may at any time repay the amount so advanced.
- (b) The member shall not be entitled to any voting rights in respect of the moneys so paid by him until the same would but for such payment, become presently payable.

43. The provisions of these Articles shall mutatis mutandis apply to the calls on debentures of the Company.

LIEN

Company's lien on Shares/Debentures

44. The Company shall have first and paramount lien upon all the shares / debentures (other than fully paid up shares / debentures) registered in the name of each member (whether solely or jointly with others) and upon the proceeds of sale thereof for all moneys (whether presently payable or not) called or payable at a fixed time in respect of such shares / debentures and no equitable interest in any shares / debentures shall be created except upon the footing and condition that this Article will have full effect. And such lien shall extend to all dividends and bonuses from time to time declared in respect of such shares / debentures. Unless otherwise agreed the registration of a transfer of shares / debentures shall operate as a waiver of the Company's lien if any on such shares / debentures. The Directors may at any time declare any shares / debentures wholly or in part to be exempt from the provisions of this Clause.

As to enforcing lien by sale

45. For the purpose of enforcing such lien, the Board may sell the shares / debentures subject thereto in such manner as they shall think fit, and for that purpose may cause to be issued a duplicate certificate in respect of such shares and / or debentures and may authorize one of their member or appoint any officer or agent to execute a transfer thereof on behalf of and in the name of such member / debenture holder. No sale shall be made until such period, as may be stipulated by the Board from time to time, and until notice in writing of the intention to sell shall have been served on such member and / or debenture holder or his legal representatives and default shall have been made by him or them in payment, fulfillment, or discharge of such debts, liabilities or engagements for fourteen days after such notice.

Application of proceeds of sale

46. (a) The net proceeds of any such sale shall be received by the Company and applied in or towards payment of such part of the amount in respect of which the lien exists as is presently payable and the residue if any, shall

(subject to a like lien for sums not presently payable as existed upon the shares before the sale) be paid to the persons entitled to the shares and / or debentures at the date of the sale.

Outsiders lien not to affect Company's lien

(b) The Company shall be entitled to treat the registered holder of any share or debenture as the absolute owner thereof and accordingly shall not (except as ordered by a Court of Competent jurisdiction or by statute required) be bound to recognise equitable or other claim to, or interest in, such shares or debentures on the part of any other person. The Company's lien shall prevail notwithstanding that it has received notice of any such claims.

FORFEITURE

If call or installment not paid notice must be given

47. (a) If any member or debenture holder fails to pay the whole or any part of any call or installment or any money due in respect of any shares or debentures either by way of principal or interest on or before the day appointed for the payment of the same or any such extension thereof as aforesaid, the Directors may at any time thereafter, during such time as the call or any installment or any part thereof or other moneys remain unpaid or a judgement or decree in respect thereof remains unsatisfied in whole or in part, serve a notice on such member or debenture holder or on the person (if any) entitled to the share by transmission requiring him to pay such call or installment or such part thereof or other moneys as remain unpaid together with any interest that may have accrued and all expenses that may have been incurred by the Company by reason of such non payment.

Form of Notice

(b) The notice shall name a day not being less than One Month from the date of the notice and a place or places, on and at which such call, or installment or such part or other moneys as aforesaid and such interest and expenses as aforesaid are to be paid. The notice shall also state that in the event of non payment of call amount with interest at or before the time and at the place appointed, the shares or debentures in respect of which the call was made or installment or such part or other moneys is or are payable will be liable to be forfeited.

In default of payment shares or debentures to be forfeited

48. If the requirements of any such notice as aforesaid are not complied with any share / debenture in respect of which such notice has been given, may at any time thereafter before payment of all calls or installments, interest and expenses or other moneys due in respect thereof, be forfeited by a resolution of the Directors to that effect. Neither the receipt by the Company of a portion of any money which shall from time to time be due from any member of the Company in respect of his shares, either by way of principal or interest, nor any indulgence granted by the Company, in respect of the payment of any such money, shall preclude the Company from thereafter proceeding to enforce a forfeiture of such shares as herein provided. Such forfeiture shall include all dividends declared or interest paid or any other moneys payable in respect of the forfeited shares or debentures and not actual paid before the forfeiture.

Entry of forfeiture in Register of members/debenture holders

49. When any shares / debentures shall have been so forfeited, notice of the forfeiture shall be given to the member or debenture holder in whose name it stood immediately prior to the forfeiture and an entry of the forfeiture with the date thereof, shall forthwith be made in the Register of Members or Debenture Holders but no forfeiture shall be invalidated by any omission or neglect or any failure to give such notice or make such entry as aforesaid.

Forfeited share/debenture to be property of Company and may be sold

50. Any share or debenture so forfeited shall be deemed to be the property of the Company, and may be sold, re-allotted or otherwise disposed of either to the original holder or to any other person upon such terms and in such manner as the Directors shall think fit.

Power to annual forfeiture

51. The Directors may, at any time, before any share or debenture so forfeited shall have been sold, re-allotted or otherwise disposed of, annual forfeiture thereof upon such conditions as they think fit.

Shareholders or Debenture holders still liable to pay money owing at time of forfeiture and interest

52. Any member or debenture holder whose shares or debentures have been forfeited shall, notwithstanding the forfeiture, be liable to pay and shall forthwith pay to the Company, all calls, installments, interest, expenses and other money owing upon or in respect of such shares or debentures at the time of the forfeiture together with interest thereon from the time of the forfeiture until payment at such rate as the Directors may determine, and the Directors may enforce the payment of the whole or a portion thereof, if they think fit, but shall not be under any obligation to do so.

Effect of forfeiture

53. The forfeiture of a share or debenture shall involve extinction at the time of forfeiture, of all interest in and all claims and demands against the Company, in respect of the share or debenture and all other rights incidental to the share or debenture, except only such of those rights as by these Articles are expressly saved.

Certificate of forfeiture

54. A certificate in writing under the hand of one Director and counter signed by the Secretary or any other officer authorised by the Directors for the purpose, that the call in respect of a share or debenture was made and notice thereof given and that default in payment of the call was made and that forfeiture of the share or debenture was made by the resolution of Directors to that effect shall be conclusive evidence of the facts stated therein as against all persons entitled to such share or debenture.

Validity of sales under Articles 45 and 50

55. Upon any sale after forfeiture or for enforcing a lien in purported exercise of the powers hereinabove given, the Directors may, if necessary, appoint some person to execute an instrument of transfer of the shares or debentures sold and cause the purchaser's name to be entered in the Register of Members or Register of Debenture Holders in respect of the shares or debentures sold, and the purchaser shall not be bound to see to the regularity of the proceedings, or to the application of the purchase money and after his name has been entered in the Register of Members or Debenture Holders in respect of such shares or debentures the validity of the sale shall not be impeached by any person, and the remedy of any person aggrieved by the sale shall be for damages only and against the Company exclusively.

Cancellation of share/debenture Certificate in respect of forfeited shares/debentures

56. Upon any sale, re-allotment or other disposal under the provisions of the preceding Articles, the certificate/s originally issued in respect of the relative shares or debentures shall (unless the same shall on demand by the Company has been previously surrendered to it by the defaulting member or debenture holder) stand cancelled and become null and void and be of no effect, and the Directors shall be entitled to issue a duplicate certificate/s in respect of the said shares or debentures to the person/s entitled thereto.

Title of purchaser and allottee of forfeited shares/debentures

57. The Company may receive the consideration, if any, given for the share or debenture on any sale, re-allotment or other disposition thereof, and the person to whom such share or debenture is sold, re-allotted or disposed of may be registered as the holder of the share or debenture and shall not be bound to see to the application of the consideration, if any, nor shall his title to the share or debenture be affected by any irregularity or invalidity in the proceedings in reference to the forfeiture, sale, re-allotment or other disposal of the share or debenture.

Surrender of Shares or Debentures

58. The Directors may, subject to the provisions of the Act, accept a surrender of any share or debenture from or by any member or debenture holder desirous of surrendering them on such terms as they think fit.

TRANSFER AND TRANSMISSION OF SHARES AND DEBENTURES

Register of Transfers

59. The Company shall keep a book to be called the "Register of Transfers" and therein shall be fairly and distinctly entered the particulars of every transfer or transmission of any share.

Form of Transfer

60. The instrument of transfer shall be in writing and all the provisions of Section 108 of the Act, 1956 and statutory modification thereof for the time being shall be duly complied with in respect of all transfer of shares and registration thereof.

'Dematerialisation of Securities'

- 60A. (1) The provisions of this Article shall apply notwithstanding any thing to the contrary contained in any other Article of these Articles.
- (2) (i) The Company shall be entitled to dematerialise its securities and to offer securities in a dematerialised form pursuant to the Depository Act, 1996.
- (ii) Option for Investors:
Every holder of or subscriber to securities of the Company shall have the option to receive security certificates or to hold the securities with a Depository. Such a person who is the beneficial owner of the Securities can at any time opt out of a Depository, if permitted, by the law, in respect of any security in the manner provided by the Depositories Act, 1996 and the

Company shall, in the manner and within the time prescribed, issue to the beneficial owner the required Certificates for the Securities.

If a person opts to hold its Security with a Depository, the Company shall intimate such depository the details of allotment of the Security.

- (iii) Securities in Depository to be in fungible form:-
All Securities of the Company held by the Depository shall be dematerialised and be in fungible form.
Nothing contained in Sections 153, 153A, 153B, 187B, 187C & 372A of the Companies Act, 1956 shall apply to a Depository in respect of the Securities of the Company held by it on behalf of the beneficial owners.
- (iv) Rights of Depositories & Beneficial Owners:-
(a) Notwithstanding anything to the contrary contained in the Act a Depository shall be deemed to be the registered owner for the purpose of effecting transfer of ownership of Security of the Company on behalf of the beneficial owner.
(b) Save as otherwise provided in (a) above, the depository as the registered owner of the Securities shall not have any voting rights or any other rights in respect of the Securities held by it.
(c) Every person holding Securities of the Company and whose name is entered as the beneficial owner in the records of the depository shall be deemed to be a member of the Company. The beneficial owner of Securities shall be entitled to all the rights and benefits and be subject to all the liabilities in respect of his Securities which are held by a depository.
- (v) Service of Documents:-
Notwithstanding anything contained in the Act to the contrary, where Securities of the Company are held in a depository, the records of the beneficial ownership may be served by such depository to the Company by means of electronic mode or by delivery of floppies or discs.
- (vi) Transfer of Securities:-
Nothing contained in Section 108 of the Companies Act, 1956 shall apply to a transfer of Securities effected by a transferor and transferee both of whom are entered as beneficial owners in the records of a depository.
- (vii) Allotment of Securities dealt with in a depository:-
Notwithstanding anything contained in the Act, where Securities are dealt with by a depository, the Company shall intimate the details thereof to the depository immediately on allotment of such securities.
- (viii) Register and Index of Members:-
The Company shall cause to be kept at its Registered Office or at such other place as may be decided, Register and Index of Members in accordance with Section 150 and 151 and other applicable provisions of the Companies Act . 1956 and the Depositories Act, 1996 with the details of Shares held in physical and dematerialised forms in any media as may be permitted by law including in any form of electronic media.
The Register and Index of beneficial owners maintained by a depository under Section 11 of the Depositories Act, 1996, shall be deemed to be the Register and Index of Members for the purpose of this Act. The Company shall have the power to keep in any state or country outside India, a Register of Members for the residents in that state or Country.

Instrument of transfer to be executed by transferor and transferee

61. Every such instrument of transfer shall be signed both by the transferor and transferee and the transferor shall be deemed to remain the holder of such share until the name of the transferee is entered in the Register of Members in respect thereof.

Directors may refuse to register transfer

62. (a) Subject to the provisions of Section 111 of the Companies Act, 1956 and Section 58 & 59 of the Companies Act, 2013 and Section 22A of the Securities Contracts (Regulation) Act, 1956, the Directors may, at their own absolute and uncontrolled discretion any by giving reasons, decline to register or acknowledge any transfer of shares whether fully paid or not and the right of refusal, shall not be affected by the circumstances that the proposed transferee is already a member of the Company but in such cases, the Directors shall within one month from the date on which the instrument of transfer was lodged with the company, send to the transferee and transferor notice of the refusal to register such transfer provided that registration of transfer shall not be refused on the ground of the transferor being either; alone or jointly with any account whatsoever except when the company has lien the shares. Transfer of shares/debentures in whatever lot shall not be refused.

(b) Nothing in Sections 108, 109 and 110 of the Companies Act, 1956 shall prejudice this power to refuse to register the transfer of or the transmission on legal documents by operation of law of the rights to, any shares or interest of a member in, any shares or debentures of the Company.

Transfer of Shares

63. (a) An application of registration of the transfer of shares may be made either by the transferor or the transferee provided that where such application is made by the transferor, no registration shall in the case of partly paid shares be effected unless the Company gives notice of the application to the transferee and subject to the provisions of Clause (d) of this Article, the Company shall unless objection is made by the transferee within two weeks from the date of receipt of the notice, enter in the Register of Members the name of the transferee in the same manner and subject to the same conditions as if the application for registration was made by the transferee.
- (b) For the purpose of clause (a) above notice to the transferee shall be deemed to have been duly given if sent by prepaid registered post to the transferee at the address given in the instrument of transfer and shall be deemed to have been duly delivered at the time at which it would have been delivered to him in the ordinary course of post.
- (c) It shall not be lawful for the Company to register a transfer of any shares unless a proper instrument of transfer duly stamped and executed by or on behalf of the transferor and by or on behalf of the transferee and specifying the name, address and occupation if any, of the transferee has been delivered to the Company along with the certificate relating to the shares and if no such certificate is in existence, along with the letter of allotment of shares. The Directors may also call for such other evidence as may reasonably be required to show the right of the transferor to make the transfer provided that where it is proved to the satisfaction of the Directors of the Company that an instrument of transfer signed by the transferor and the transferee has been lost, the Company may, if the Directors think fit, on an application in writing made by the transferee and bearing the stamp required by an instrument of transfer register the transfer on such terms as to indemnity as the Directors may think fit.
- (d) Nothing in clause (c) above shall prejudice any power of the Company to register as share holder any person to whom the right to any share has been transmitted by operation of law.
- (e) The Company shall accept all applications for transfer of shares / debentures, however, this condition shall not apply to requests received by the Company.
- (A) for splitting of a share or debenture certificate into several scripts of very small denominations;
 - (B) proposals for transfer of shares / debentures comprised in a share / debenture certificate to several parties involving, splitting of a share / debenture certificate into small denominations and that such split / transfer appears to be unreasonable or without any genuine need.
- (i) transfer of equity shares / debentures made in pursuance of any statutory provisions or an order of a Competent Court of law;
 - (ii) the transfer of the entire equity shares / debentures by an existing shareholder / debenture holder of the Company holding under one folio less than 10 (ten) Equity Shares or 10 (ten) Debentures (all relating to the same series) less than in market lots by a single transfer to a single or joint transferee.
 - (iii) the transfer of not less than 10 (ten) Equity shares or 10 (ten) Debentures (all relating to the same series) in favour of the same transferee(s) under two or more transfer deeds, out of which one or more relate(s) to the transfer of less than 10 (ten) Equity Shares / 10 (ten) debentures.
 - (iv) the transfer of less than 10 (ten) Equity Shares or 10 (ten) Debentures (all relating to the same series) to the existing share holder / debenture holder subject to verification by the Company.
Provided that the Board may in its absolute discretion waive the aforesaid conditions in a fit and proper case(s) and the decision of the Board shall be final in such case(s).
- (f) Nothing in this Article shall prejudice any power of the Company to refuse to register the transfer of any share.

Custody of Instrument of transfer

64. The instrument of transfer shall after registration be retained by the Company and shall remain in their custody. All instruments of transfer which the Directors may decline to register shall on demand be returned to the persons depositing the same. The Directors may cause to be destroyed all transfer deeds lying with the Company after such period as they may determine.

Transfer books and Register of members when closed

65. The Board shall have power on giving not less than seven days' previous notice by advertisement in some newspaper circulating in the district in which the office of the Company is situate, to close the Transfer books, the

Register of members or Register of debenture holders at such time or times and for such period or periods, not exceeding thirty days at a time and not exceeding in the aggregate forty five days in each year.

Transfer to Minors etc.

66. Only fully paid shares or debentures shall be transferred to a minor acting through his / her legal or natural guardian. Under no circumstances, shares or debentures be transferred to any insolvent or a person of unsound mind.

Title to shares of deceased holder

67. The executors or administrators of a deceased member (not being one or two or more joint holders) or the holder of a deceased member (not being one or two or more joint holders) shall be the only persons whom the Company will be bound to recognise as having any title to the shares registered in the name of such member, and the Company shall not be bound to recognise such executors or administrators or the legal representatives unless they shall have first obtained probate or Letters of Administration or a Succession Certificate, as the case may be, from a duly constituted competent Court in India, provided that in any case where the Directors in their absolute discretion think fit, the Directors may dispense with the production of probate or Letters of Administration or a Succession Certificate upon such terms as to indemnity or otherwise as the Directors in their absolute discretion may think necessary under Article 70 register the name of any person who claims to be absolutely entitled to the shares standing in the name of a deceased member, as a member.

Registration of persons entitled to share otherwise than by transfer

68. (a) Subject to the provisions of Articles 67 and 77(d), any person becoming entitled to any share in consequence of the death, lunacy, bankruptcy or insolvency of any member or by any lawful means other than by a transfer in accordance with these presents, may with the consent of the Directors (which they shall not be under any obligation to give) upon producing such evidence that he sustains the character in respect of which he proposes to act under this Article or of such titles as the Directors shall think sufficient, either be registered himself as a member in respect of such shares or elect to have some person nominated by him and approved by the Directors registered as a member in respect of such shares. Provided nevertheless that if such person shall elect to have his nominee registered he shall testify his election by executing in favour of his nominee an instrument of transfer in accordance with the provisions herein contained and until he does so, he shall not be free from any liability in respect of such shares.
- (b) A transfer of the shares or other interest in the Company of a deceased member thereof made by his legal representative shall, although the legal representative is not himself a member be as valid as if he had been a member at the time of the execution of the instrument of transfer.

‘Nomination’

- (c) (1) Every Shareholder or Debenture holder or Deposit holder of the Company, may at any time, nominate a person to whom his Shares or Debentures or Deposits shall vest in the event of his death in such manner as may be prescribed under the Act.
- (2) Where the Shares or Debentures or Deposits of the Company are held by more than one person jointly, joint holders may together nominate a person to whom all the rights in the Shares or Debentures or Deposits as the case may be shall vest in the event of death of all the joint holders in such manner as may be prescribed under Section 58A (11) and 109A of the Act.
- (3) Notwithstanding anything contained in any other law for the time being in force or in any disposition, whether testamentary or otherwise, where a nomination made in the manner aforesaid purports to confer on any person the right to vest the Shares or Debentures or Deposits, the nominee shall, on the death of the Shareholder or Debenture holder or Deposit holder, as the case may be on the death of the joint holders become entitled to all the rights in such Shares or Debentures or Deposits as the case may be, all the joint holders, in relation to such Shares or Debentures or Deposits, to the exclusion of all other persons, unless the nomination is varied or cancelled in the manner as may be prescribed under the Act.
- (4) Where the nominee is a minor, it shall be lawful for the holder of the Shares or Debentures or Deposits, to make the nomination to appoint any person to become entitled to Share in, or Debentures or Deposits of, the Company, in the manner prescribed under the Act, in the event of his death, during the minority.

‘Transmission of Shares or Debentures’

- (d) (1) A nominee, upon production of such evidence as may be required by the Board and subject to provisions of Section 109B of the Act and as hereinafter provided, elect, either –
- (a) to register himself as holder of the Share or Debenture, as the case may be; or
- (b) to make such transfer of the Share or Debenture, as the deceased Shareholder or Debenture holder, as the case may be, could have made.

(2) if the nominee elects to be registered as holder of the Share or Debenture himself, as the case may be, he shall deliver or send to the Company, a notice in writing signed by him stating that he so elects and such notice shall be accompanied with the death certificate of the deceased Shareholder or Debenture holder, as the case may be.

(3) a nominee shall be entitled to the share dividend and other advantages to which he would be entitled if he were the registered holder of the Share or Debenture. Provided that he shall not, before being registered as a member, be entitled to exercise any right conferred by membership in relation to meeting of the Company.

provided further that Board may, at any time, give notice requiring any such person to elect either to be registered himself or to transfer the Share or Debenture, and if the notice is not complied with within ninety days, the Board may thereafter withhold payment of all dividends, bonuses or other monies payable in respect of the Share or Debenture, until the requirements of the notice have been complied with.

Claimant to be entitled to same advantage

69. The person becoming entitled to a share by reason of the death, lunacy, bankruptcy or insolvency of the holder shall be entitled to the same dividends and other advantages to which he would be entitled as if he were registered holder of the shares except that he shall not before being registered as a member in respect of the share, be entitled in respect of it, to exercise any right conferred by membership in relation to the meeting of the Company provided that the Board may at any time give notice requiring any such persons to elect either to be registered himself or to transfer shares and if the notice is not complied within sixty days, the Board may thereafter withhold payment of all dividends, interest, bonuses or other moneys payable in respect of the share unit the requirements of the notice have been complied with.

Persons entitled may receive dividend without being registered as member

70. A person entitled to a share by transmission shall, subject to the right of the Directors to retain such dividends, bonuses or moneys as hereinafter provided be entitled to receive, and may give a discharge for any dividends, bonuses or other moneys payable in respect of the share / debenture.

71. Article 70 shall not prejudice the provisions of Articles 44 and 55.

Refusal to register nominee

72. The Directors shall have the same right to refuse on legal ground to register a person entitled by transmission to any shares or his nominee as if he were the transferee named in an ordinary transfer presented for registration.

Directors may require evidence of transmission

73. Every transmission of a share shall be verified in such manner as the Directors may require, and the Company may refuse to register any such transmission until the same be so verified or until or unless an indemnity be given to the Company with regard to such registration which the Directors at their discretion shall consider sufficient, provided nevertheless that there shall not be any obligation on the Company or the Directors to accept any indemnity.

No Fees on transfer or transmission

74. No fees shall be charged for registration of transfer transmission, Probate, Succession Certificate and Letters of administration, Certificate of Death of Marriage, Power of Attorney or similar other document.

The Company not liable for disregard of a notice prohibiting registration of transfer

75. The Company shall incur no liability or responsibility whatsoever in consequence of its registering or giving effect to any transfer of shares made or purporting to be made by any apparent legal owner thereof (as shown or appearing in the Register of members) to the prejudice of persons having or claiming any equitable right, title or interest to or in the said shares, notwithstanding that the Company may have had notice of such equitable right, title or interest or notice prohibiting registration of such transfer and may have entered such notice referred thereto in any book of the Company and the Company shall not be bound or required to regard or attend or give effect to any notice which may be given to it of any equitable right, title or interest or be under any liability whatsoever for refusing or neglecting so to do, though it may have been entered or referred to in some book of the Company, but the Company shall nevertheless be at liberty to regard and attend to any such notice and give affect thereto if the Directors shall so think fit.

76. The provisions of these Articles shall mutatis mutandis apply to the transfer or transmission by operation of law, of debentures of the Company.

BORROWING POWERS

Restriction on powers of the Board

78. The Board of Directors shall not, except with the consent of the Company in General Meeting by way of special resolution and subject to Article 172 of the Articles of Association of the Company :
- (a) sell, lease or otherwise dispose of the whole or substantially the whole, of the undertaking of the Company, or where the Company owns more than one undertaking of the whole, or substantially the whole, of any such undertaking.
 - (b) remit, or give time for the repayment of any debt due by a Director.
 - (c) invest, otherwise than in trust securities the amount of compensation received by the Company as a result of any merger or amalgamation.
 - (d) borrow monies where the moneys to be borrowed, together with the moneys already borrowed by the Company (apart from temporary loans obtained from the Company's bankers in the ordinary course of business) will exceed the aggregate of the paid-up Capital of the Company and its free reserves, that is to say, reserves not set apart for any specific purpose.
 - (e) contribute, to bona fide charitable and other funds any amounts the aggregate of which will, in any financial year, exceed five percent of its average net profits for the three immediately preceding financial years.
- Explanation: Every resolution passed by the Company in General Meeting in relation to the exercise of the power referred to in clause (d) shall specify the total amount up to which money may be borrowed by the Board of Directors under clause (d).

Conditions on which money may be borrowed

79. The Directors may raise and secure the payment of such sum or sums in such manner and upon such terms and conditions in all respects as they think fit, and in particular by the issue of bonds, perpetual or redeemable, debenture or debenture stocks or any mortgage or charge or other security on the undertaking of the whole or any part of the property of the Company (both present and future) including its uncalled Capital for the time being.

Securities may be assignable free from equities

81. Debentures, debenture stocks, bonds or other securities may be made assignable free from any equities between the Company and the person to whom the same may be issued.

Mortgage of uncalled Capital

83. If any uncalled Capital of the Company is included in or charged by any mortgage or other security the Directors shall, subject to the provisions of the Act and these Articles, make calls on the members in respect of such uncalled Capital in trust for the person in whose favour such mortgage or security is executed.

Indemnity may be given

84. If the Directors or any of them or any other person shall become personally liable for the payment of any sum primarily due from the Company, the Directors may execute or cause to be executed any mortgage, charge or security over or affecting the whole or any part of the assets of the Company by way of indemnity to secure the Directors or person so becoming liable as aforesaid from any loss in respect of such liability.

Registration of charges

85. (a) The provisions of the Act relating to registration of charges shall be complied with.
(b) In the case of a charge created out of India and comprising solely property situated outside India, the provisions of Section 125 of the Companies Act, 1956 shall also be complied with.
(c) Where a charge is created in India but comprises property outside India, the instrument creating or purporting to create the charge under Section 125 of the Act or a copy thereof verified in the prescribed manner, may be filed for registration, notwithstanding that further proceedings may be necessary to make the charge valid

or effectual according to the law of the country in which the property is situated, as provided by Section 125 of the Companies Act, 1956.

(d) Where any charge on any property of the Company required to be registered under Section 125 of the Companies Act, 1956 has been so registered any persons acquiring such property or any part thereof or any share as interest therein shall be deemed to have notice of the charge as from the date of such registration.

(e) In respect of registration of charges on properties acquired subject to charge, the provisions of Section 127 of the Companies Act, 1956 shall be complied with.

(f) The Company shall comply with the provisions of Section 128 of the Companies Act, 1956 relating to particulars in case of series of debentures entitling holders *pari passu*.

(g) The Company shall comply with the provisions of Section 129 of the Companies Act, 1956 in regard to registration of particulars of commission, allowance or discount paid or made, directly or indirectly, in connection with the debentures.

(h) The Provisions of Section 133 of the Companies Act, 1956 as to endorsement of Certificate of registration on debenture or Certificate of debenture stock shall be complied with by the Company.

(i) The Company shall comply with the provisions of Section 134 of the Companies Act, 1956 as regards registration of particulars of every charge and of every series of debentures.

(j) As to modification of charges, the Company shall comply with the provisions of Section 135 of the Companies Act, 1956.

(k) The Company shall comply with the provisions of Section 136 of the Companies Act, 1956 regarding keeping a copy of instrument creating charge at the registered office of the Company and comply with the provisions of Section 137 of the Companies Act, 1956 in regard to entering in the register of charges any appointment of Receiver or Managers as therein provided.

(l) The Company shall also comply with the provisions of section 138 of the Companies Act, 1956 as to reporting satisfaction of any charge and procedure thereafter.

(m) The Company shall keep at its registered office a Register of charges and enter therein all charges specifically affecting any property of the Company and all floating charges on the undertaking or on any property of the company giving in each case :

(i) a short description of the property charged;

(ii) the amount of the charge; and

(iii) except in the case of securities to bearer, the names of persons entitled to the charge.

(n) Any creditor or member of the Company and any other person shall have the right to inspect copies of instruments creating charges and the Company's Register of charges in accordance with and subject to the provisions of Section 144 of the Act.

CONVERSION OF SHARES INTO STOCK AND RECONVERSION

Shares may be converted into stock

91. The Company in general meeting may convert any paid up shares into stock and when any shares shall have been converted into stock, the several holders of such stock may thenceforth transfer their respective interest therein or any part of such interests, in the same manner and subject to the same regulations as, and subject to which shares from which the stock arise might have been transferred, if no such conversion had taken place, or as near thereto as circumstances will admit. The Company may at any time reconvert any stock into paid up shares of any denomination.

Rights of stock holders

92. The holders of stock shall, according to the amount of stock held by them, have the same right, privileges and advantages as regards dividends, voting at meeting of the company, and other matters, as if they held the shares from which the stock arose, but no such privileges or advantage (except participation in the dividends and profit of the Company and in the assets on winding up) shall be conferred by an amount of stock which would not, if existing in shares, have conferred that privileges or advantages.

GENERAL MEETINGS

93. Annual General Meeting

Subject to the provisions contained in Sections 166 and 210 of the Act, as far as applicable, the Company shall in each year hold, in addition to any other meetings, a general meeting as its annual general meeting, and shall specify, the meeting as such in the Notice calling it; and not more than fifteen months shall elapse between the date of one annual general meeting of the Company and that of the next.

Provided that if the Registrar for any special reason extends the time within which any annual general meeting shall be held, then such annual general meeting may be held within such extended period.

Summary of Annual General Meeting

The Company may in any one general meeting fix the place for its any annual general meetings. Every member of the Company shall be entitled to attend either in person or by proxy and the Auditor of the Company shall have the right to attend and to be heard at any general meeting which he attends on any part of the business which concerns him as Auditor. At every annual general meeting of the Company, there shall be laid on the table, the Director's Report the audited statements of accounts and auditor's report (if any, not already incorporated in the audited statement of accounts). The proxy registered with the Company and Register of Director's Share holdings of which latter register shall remain open and accessible during the continuance of the meeting. The Board shall cause to prepare the Annual list of members, summary of Share Capital, Balance Sheet and Profit and Loss Account and forward the same to the Registrar in accordance with Sections 159, 161 and 220 of the Companies Act, 1956.

Time and place of Annual General Meeting

94. Every annual general meeting shall be called at any time during business hours, on a day that is not a public holiday, and shall be held either at the registered office of the Company or at some other place within the city, town or village in which the registered office of the Company is situate, and the notice calling the meeting shall specify it as the annual general meeting.

Sections 102, 103, 105 & 107 of the Companies Act, 2013 shall apply to meetings.

95. Sections 102, 103, 105 & 107 of the Companies Act, 2013 with such adaptations and modifications, if any, as may be prescribed shall apply with respect to meetings of any class of members or debenture holders of the Company in like manner as they apply with respect to general meetings of the Company.

Powers of Director's to call Extraordinary General Meeting

96. The Directors may call an extraordinary general meeting of the Company whenever they think fit.

Calling of Extra Ordinary General Meeting on requisition

97. (a) The Board of Directors of the Company shall on the requisition of not less than one-tenth of such of the paid-up share capital of the Company as on that date carries the right to voting, forthwith proceed duly to call an Extraordinary general meeting of the Company.
- (b) The requisition shall set out the matters for the consideration of which the meeting is to be called, shall be signed by the requisitionists, and shall be deposited at the registered office of the Company.
- (c) The requisition may consist of several documents in like form, each signed by one or more requisitionists.
- (f) If the Board does not, within twenty one days from the date of the deposit of a valid requisition in regard to any matters, proceed duly to call a meeting for the consideration of those matters then on a day not later than forty five days from the date of the deposit of the requisition, the meeting may be called by the requisitionists themselves within a period of three months from the date of requisition.
- (g) A meeting, called under clause (f) above, by the requisitionists or any of them:
- (i) shall be called in the same manner, as nearly as possible, as that in which meetings are to be called by the Board; but
 - (ii) shall not be held after the expiration of three months from the date of the deposit of the requisition.
- Explanation: Nothing in clause (g) (ii) above, shall be deemed to prevent a meeting duly commenced before the expiry of the period of three months aforesaid, from adjourning to some day after the expiry of that period.
- (h) Where two or more persons hold any shares or interest in the Company jointly, a requisition, or a notice calling a meeting, signed by one or some of them shall, for the purpose of this Article, have the same force and effect as if it had been signed by all of them.
- (i) Any reasonable expenses incurred by the requisitionists by reason of the failure of the Board duly to call a meeting shall be repaid to the requisitionists by the Company; and any sum so repaid shall be retained by the Company out of any sums due or to become due from the Company by way of fees or other remuneration for their services to such of the Directors as were in default.

Length of notice for calling meeting

98. (a) A general meeting of the Company may be called by giving not less than twenty one days' notice in writing.
- (b) A general meeting of the Company may be called after giving shorter notice than that specified in clause (a) above, if consent is accorded thereto;
- (i) in the case of an annual general meeting by all the members entitled to vote thereat; and

- (ii) in the case of any other meeting, by members of the Company holding not less than 95 (ninety five) per cent of such part of the paid up capital of the Company as gives a right to vote at the meeting; Provided that where any members of the Company are entitled to vote only on some resolution or resolutions to be moved at the meeting and not on the others, those members shall be taken into account for the purposes of this clause in respect of the former resolution or resolutions and not in respect of the latter.

Contents and manner of service of notice and persons on whom it is to be served

99. (a) Every notice of a meeting of the Company shall specify the place and the day and hour of the meeting and shall contain a statement of the business to be transacted thereat.
- (b) Notice of every meeting of the Company shall be given :
- (i) to every member of the Company, in any manner authorised by sub-sections (1) to (4) of Section 53 of the Act;
 - (ii) to the persons entitled to a share in consequence of the death or insolvency of a member, by sending it through the post in a prepaid letter addressed to them by name, or by the title or representatives of the deceased or assignees of the insolvent, or by any like description, at the address, if any, in India supplied for the purpose by the persons claiming to be so entitled, or until such an address has been so supplied, by giving the notice in any manner in which it might have been given if the death or insolvency had not occurred;
 - (iii) to the Auditor or Auditors for the time being of the Company in any manner authorised by Section 53 of the Act in the case of any member of members of the Company and
 - (iv) to all the Directors of the Company
- Provided that where the notice of a meeting is given by advertising the same in a newspaper circulating in the neighbourhood of the registered office of the Company under sub-section (3) of Section 53 of the Act, the statement of material facts referred to in Section 102 of the Companies Act, 2013 need not be annexed to the notice as required by that Section but it shall be mentioned in the advertisement that the statement has been forwarded to the members of the Company.
- (c) The accidental omission to give notice to, or the non-receipt of notice by any member or other person to whom it should be given shall not invalidate the proceedings at the meeting.

Explanatory statement to be annexed to notice

100. (A) For the purpose of this Article:
- (i) in the case of an annual general meeting, all business to be transacted at the meeting shall be deemed special with the exception of business relating to
 - (a) the consideration of the accounts, balance sheet and the reports of the Board of Directors and auditors.
 - (b) the declaration of a dividend;
 - (c) the appointment of Directors in the place of those retiring, and
 - (d) the appoint of and the fixing of the remuneration of the auditors, and
 - (ii) in the case of any other meetings, all business shall be deemed special.
- (B) Where any items of business to be transacted at the meeting are deemed to be special as aforesaid, there shall be annexed to the notice of the meeting a statement setting out:
- (i) the nature of concern or interest, financial or otherwise, if any, in respect of each items of :
 - (a) every director and manager, if any;
 - (b) every other Key managerial personnel; and
 - (c) relatives of the persons mentioned in sub-clauses (a) & (b);
 - (ii) any other information and facts that may enable members to understand the meaning, scope and implications of the items of business and to take decision thereon.

Provided that where any item of special business to be transacted at a meeting of the company relates to or affects any other company, the extent of shareholding interest in that other company of every promoter, director, manager, if any, and of every other key managerial personnel of the first mentioned company shall, if the extent of such shareholding is not less than two per cent. of the paid-up share capital of that company, also be set out in the statement.

(C) Where any item of business refers to any document, which is to be considered at the meeting, the time and place where such document can be inspected shall be specified in the statement under sub-Article (B) of this Article.

Quorum for meeting

101. (a) Unless the number of members as on date of meeting are not more than one thousand, five members personally present shall be the quorum for a general meeting of the company.
(b) In any other case, the quorum shall be decided as under:
(i) fifteen members personally present if the number of members as on the date of meeting is more than one thousand but up to five thousand;
(ii) thirty members personally present if the number of members as on the date of the meeting exceeds five thousand;

If quorum not present meeting to be dissolved or adjourned

- (c) (i) If within half an hour from the time appointed for holding a meeting of the Company, a quorum is not present, the meeting, if called upon by requisition of members, shall stand dissolved.
(ii) In any other case, the meeting shall stand adjourned to the same day in the next week at the same time and place or to such other day and at such other time and place, as the Board may determine.

Provided that in case of an adjourned meeting or of a change of day, time or place of meeting under clause (a), the company shall give not less than three days notice to the members either individually or by publishing an advertisement in the newspapers (one in English and one in vernacular language) which is in circulation at the place where the registered office of the company is situated.

Adjourned meeting to transact business

- (d) If at the adjourned meeting also, a quorum is not present within half an hour from the time appointed for holding the meeting, the members present shall be the quorum.

Presence of quorum

102. (a) No business shall be transacted at any general meeting unless the requisite quorum be present at the commencement of the business.

Business confined to election of chairman whilst chair vacant

- (b) No business shall be discussed or transacted at any general meeting except the election of a Chairman whilst the Chair is vacant.

Chairman of general meeting

- (c) (i) The chairman of the Board of Directors shall be entitled to take the chair at every general meeting. If there be no Chairman or if at any meeting he shall not be present within 15 (fifteen) minutes after the time appointed for holding such meeting or is unwilling to act, the Directors present may choose one of themselves to be Chairman and in default of their doing so, the members present shall choose one of the Directors to be Chairman and if no Directors present be willing to take the chair, the members present shall choose one of the themselves to be the Chairman.
(ii) If at any meeting a quorum of members shall be present, and the Chair shall not be taken by the Chairman or Vice Chairman of the Board or by a Director at the expiration of 15 (fifteen) minutes from the time appointed for holding the meeting or if before the expiration of that time all the Directors shall decline to take the Chair, the members present shall choose one of their members to be the Chairman of the meeting.
(iii) If a poll is demanded on the election of the chairman, it shall be taken forthwith in accordance with the provisions of the Companies Act, 2013 and the Chairman elected on show of hands under sub-section (1) shall continue to be the chairman of the meeting until some other person is elected as Chairman as a result of the poll and such other person shall be the Chairman for the rest of the meeting.

Chairman with consent may adjourn the meeting

- (d) The Chairman with the consent of the meeting may adjourn any meeting from time to time and place to place in the city, town or village where the registered office of the Company is situate.

Business at adjourned meeting

- (e) No business shall be transacted at any adjourned meeting other than the business which might have been transacted at the meeting from which the adjournment took place.

Notice of adjourned meeting

- (f) When a meeting is adjourned only for thirty days or more, notice of the adjourned meeting shall be given as in the case of original meeting.

In what cases poll taken with or without adjournment

- (g) Any poll duly demanded on the election of a Chairman of a meeting or any question of adjournment shall be taken at the meeting forthwith, save as aforesaid, any business other than that upon which a poll has been demanded may be proceeded with pending the taking of the poll.

103. **Proxies**

- (a) Any member of the Company entitled to attend and vote at a meeting of the Company shall be entitled to appoint any other person (whether a member or not) as his proxy to attend and vote instead of himself. A member

(and in the case of joint holders all holders) shall not appoint more than one person as proxy. A proxy so appointed shall not have any right to speak at the meeting.

Provided that unless where the proxy is appointed by a body corporate a proxy shall not be entitled to vote except on a poll.

(b) In every notice calling a meeting of the Company there shall appear with reasonable prominence a statement that a member entitled to attend and vote is entitled to appoint a proxy to attend and vote instead of himself, and that a proxy need not be a member.

(c) The instrument appointing a proxy or any other document necessary to show the validity or otherwise relating to the appointment of a proxy shall be lodged with the Company not less than 48 (forty eight) hours before the meeting in order that the appointment may be effective thereat.

(d) The instrument appointing a proxy shall:

(i) be in writing, and

(ii) be signed by the appointer or his attorney duly authorised in writing or, if the appointer is a body corporate, be under its seal or be signed by an officer or an attorney duly authorised by it.

Form of proxy

(e) Every instrument of proxy whether for a specified meeting or otherwise shall, as nearly as circumstances will admit, be in usual common form.

(f) An instrument appointing a proxy, if in any of the forms set out in Schedule IX to the Act shall not be questioned on the ground that it fails to comply with any special requirements specified for such instrument by these Articles.

(g) Every member entitled to vote at a meeting of the Company, or on any resolution to be moved thereat, shall be entitled during the period beginning 24 (twenty four) hours before the time fixed for the commencement of the meeting and ending with the conclusion of the meeting, to inspect the proxies lodged at any time during the business hours of the Company, provided not less than 3 (three) days' notice in writing of the intention so to inspect is given to the Company.

VOTES OF MEMBERS

Restrictions on exercise of voting rights of members who have not paid calls

104. (a) No member shall exercise any voting right in respect of any shares registered in his name on which any calls or other sums presently payable by him have not been paid or in regard to which the Company has and has exercised any right of lien.

(b) Where the shares of the Company are held in trust, the voting power in respect of such shares shall be regulated by the provisions of Section 187 B of the Companies Act, 1956.

Restriction on exercise of voting right in other cases to be void

105. A member is not prohibited for exercising his voting right on the ground that he has not held his share or other interest in the Company for any specified period preceding the date on which the vote is taken, or on any other ground not being a ground set out in Article 104.

Equal rights of share holders

106. Any shareholder whose name is entered in the Register of members of the Company shall enjoy the same rights and be subject to the same liabilities as all other shareholders of the same class.

Voting to be by show of hands in first instance

107. At any general meeting a resolution put to vote at the meeting shall unless a poll is demanded under Section 179 of the Companies Act, 1956 be decided on a show of hands.

108. (a) Subject to the provisions of the Act, upon show of hands every member entitled to vote and present in person shall have one vote, and upon a poll every member entitled to vote and present in person or by proxy shall have one vote, for every share held by him.

No voting by proxy on show of hands

(b) No member not personally present shall be entitled to vote on a show of hands unless such member is a body corporate present by proxy or by a representative duly authorised under Sections 187 or 187A and Section 112 & 113 (to the extent notified) of the Companies Act, 2013 in which case such proxy or representative may vote on a show of hands as if he were a member of the Company.

How members non compos minutes and minor may vote

(c) A member of unsound mind or in respect of whom an order has been made by any court having jurisdiction in lunacy, may vote, whether on a show of hands or on a poll by his committee or other legal guardian and any such committee or guardian may on poll vote by proxy; if any member be a minor the vote in respect of

his share or shares shall be by his guardians or any one of his guardians, if more than one, to be selected in case of dispute by the Chairman of the meeting.

(d) Votes in respect of shares of deceased or insolvent members etc.

Subject to the provisions of the Act and other provisions of these Articles, any person entitled under the transmission clause to any shares may vote at any general meeting in respect thereof as if he was the registered holder of such shares, provided that at least 48 (forty eight) hours before the time of holding the meeting or adjourned meeting as the case may be at which he proposes to vote, he shall satisfy the Directors of his right to such shares unless the Directors shall have previously admitted his right to vote at such meeting in respect thereof.

(e) Custody of Instrument

If any such instrument of appointment be confined to the object of appointing proxy or substitute for voting at meetings of the Company, it shall remain permanently or for such time as the Directors may determine in the custody of the Company; if embracing other objects a copy thereof examined with the original, shall be delivered to the Company to remain in the custody of the Company.

(f) Validity of votes given by proxy notwithstanding death of members etc.

A vote given in accordance with the terms of an instrument of proxy shall be valid notwithstanding the previous death of the principal or revocation of the proxy or the transfer of the share in respect of which the vote is given, provided that no intimation in writing of the death, revocation or transfer shall have been received at the registered office of the Company before the meeting.

(g) Time for objections for vote

No objection shall be made to the validity of any vote except at the meeting or poll at which such vote shall be tendered and every vote whether given personally or by an agent or proxy or representative not disallowed at such meeting or poll shall be deemed valid for all purpose of such meeting or poll whatsoever.

(h) Chairman of any meeting to be the judge of any vote

The Chairman of any meeting shall be the sole judge of the validity of every vote tendered at such meeting. The Chairman present at the taking of a poll shall be the sole judge of the validity of every vote tendered at such poll.

Chairman's declaration of result of voting by show of hands to be conclusive

109. A declaration by the Chairman in pursuance of Section 177 of the Companies Act, 1956 and Section 107 of the Companies Act, 2013 that on a show of hands, a resolution has or has not been carried, either unanimously or by a particular majority, and an entry to that effect in the books containing the minutes of the proceedings of the Company, shall be conclusive evidence of the fact, without proof of the number or proportion of the votes cast in favour of or against such resolution.

Demand for poll

110. (a) Before or on the declaration of the result of the voting on any resolution of a show of hands, a poll may be ordered to be taken by the Chairman of the meeting of his own motion and shall be ordered to be taken by him on a demand made in that behalf by any member or members present in person or by proxy and holding shares in the Company which confer a power to vote on the resolution not being less than one-tenth of the total voting power in respect of the resolution or on which an aggregate sum of not less than fifty thousand rupees has been paid up.
(b) The demand for a poll may be withdrawn at any time by the person or persons who made the demand.

Time of taking poll

111. (a) A poll demanded on a question of adjournment shall be taken forthwith.
(b) A poll demanded on any other question (not being a question relating to the election of a Chairman which is provided for in Section 175 of the Act) shall be taken at such time not being later than 48 (forty eight) hours from the time when the demand was made, as the Chairman may direct.

Right of a member to use his votes differently

112. On a poll taken at a meeting of the Company a member or other person entitled to vote for him as the case may be, need not, if he votes, use, all his votes or cast in the same way all the votes he uses.

Scrutineers at poll

113. (a) Where a poll is to be taken, the Chairman of the meeting shall appoint two scrutineers to scrutinise the votes given on the poll and to report thereon to him.
(b) The Chairman shall have power, at any time before the result of the poll is declared, to remove a scrutineer from office and to fill vacancies in the office of scrutineer arising from such removal or from any other cause.

(c) Of the two scrutineers appointed under this article, one shall always be a member (not being an officer or employee of the Company) present at the meeting, provided such a member is available and willing to be appointed.

Manner of taking poll and result thereof

114. (a) Subject to the provisions of the Act, the Chairman of the meeting shall have power to regulate the manner in which a poll shall be taken.
(b) The result of the poll shall be deemed to be the decision of the meeting on the resolution on which the poll was taken.

Casting Vote

115. In the case of an equality of votes, whether on a show of hands or on a poll, the Chairman of the meeting at which the show of hands takes place or at which the poll is demanded shall be entitled to a casting vote in addition to his own vote or votes to which he may be entitled as a member.

Representation of Body Corporate

116. A body corporate (whether a Company within the meaning of the Act or not) if it is a member or creditor (including a holder of debentures) of the Company may in accordance with the provisions of Section 113 of the Companies Act, 2013 authorise such person by a resolution of its Board of Directors as it thinks fit, to act as its representative at any meeting of the Company or of any class of members of the Company or at any meeting of creditors of the Company.

Representation of the President of India or Governors

117. (a) The President of India or the Governor of a State if he is a member of the Company may appoint such person as he thinks fit to act as his representative at any meeting of the Company or at any meeting of any class of members of the Company in accordance with provisions of Section 112 of the Companies Act, 2013 of the Act or any other statutory provision governing the same.
(b) A person appointed to act as aforesaid shall for the purposes of the Act be deemed to be a member of such a Company and shall be entitled to exercise the same rights and powers (including the right to vote by proxy) as the President or as the case may be the Governor could exercise, as a member of the Company.
(c) **Public Trustee**
The Company shall observe the provisions of Section 187B of the Act, in regard to the Public Trustee.

Circulation of member's resolution

118. The Company shall comply with provisions of Section 111 of the Companies Act, 2013, relating to circulation of member's resolution.

Resolution requiring special notice

119. The Company shall comply with provisions of Section 190 of the Act relating to resolution requiring special notice.

Resolutions passed at adjourned meeting

120. The provisions of Section 191 of the Companies Act, 1956 and Section 116 of Companies Act, 2013 shall apply to resolutions passed at an adjourned meeting of the Company, or of the holders of any class of shares in the Company and of the Board of Directors of the Company and the resolutions shall be deemed for all purposes as having been passed on the date on which in fact they were passed and shall not be deemed to have been passed on any earlier date.

Registration of resolutions and agreements

121. The Company shall comply with the provisions of Section 192 of the Companies Act, 1956 relating to registration of certain resolutions and agreements.

Minutes of proceedings of general meeting and of Board and other meetings

122. (a) The Company shall cause minutes of all proceedings of general meetings, and of all proceedings of every meeting of its Board of Directors or of every Committee of the Board to be kept by making within thirty days of the conclusion of every such meeting concerned, entries thereof in books kept for the purpose with their pages consecutively numbered.
(b) Each page of every such book shall be initialed or signed and the last page of the record of proceedings of each meeting in such books shall be dated and signed :

- (i) in the case of minutes of proceedings of the Board or of a Committee thereof by the Chairman of the said meeting or the Chairman of the next succeeding meeting.
- (ii) in the case of minutes of proceedings of the general meeting by Chairman of the said meeting within the aforesaid period, of thirty days or in the event of the death or inability of that Chairman within that period, by a Director duly authorised by the Board for the purpose.
- (c) In no case the minutes of proceedings of a meeting shall be attached to any such book as aforesaid by pasting or otherwise.
- (d) The minutes of each meeting shall contain a fair and correct summary of the proceedings thereat.
- (e) All appointments of officers made at any of the meetings aforesaid shall be included in the minutes of the meeting.
- (f) In the case of a meeting of the Board of Directors or of a Committee of the Board, the minutes shall also contain:
 - (i) the names of the Directors present at the meetings, and
 - (ii) in the case of each resolution passed at the meeting, the names of the Directors, if any dissenting from or not concurring in the resolution.
- (g) Nothing contained in Clauses (a) to (d) hereof shall be deemed to require the inclusion in any such minutes of any matter which in the opinion of the Chairman of the meeting:
 - (i) is or could reasonably be regarded, as defamatory of any person
 - (ii) is irrelevant or immaterial to the proceedings; or
 - (iii) is detrimental to the interests of the Company.The Chairman shall exercise an absolute discretion in regard to the inclusion or non-inclusion of any matter in the minutes on the grounds specified in this clause.

Minutes to be considered to be evidence

- (h) The minutes of meetings kept in accordance with the provisions of Section 193 of the Companies Act, 1956 shall be evidence of the proceedings recorded therein.

Presumptions to be drawn where minutes duly drawn and signed

123. Where minutes of the proceedings of any general meeting of the Company or of any meeting of its Board of Directors or of a Committee of the Board have been kept in accordance with the provisions of Section 193 of the Act then, until the contrary is proved, the meeting shall be deemed to have been duly called and held, and all proceedings thereat to have duly taken place and in particular all appointments of Directors or Liquidators made at the meeting shall be deemed to be valid and the minutes shall be evidence of the proceedings recorded therein.

Inspection of Minutes Books of General Meetings

124. (a) The books containing the minutes of the proceedings of any general meeting of the Company shall;
 - (i) be kept at the registered office of the Company, and
 - (ii) be open, during the business hours to the inspection of any member without charge subject such reasonable restrictions as the Company may, in general meeting impose so however that not less than two hours in each day are allowed for inspection.(b) Any member shall be entitled to be furnished, within seven days after he has made a request in that behalf of the Company, with a copy of any minutes referred to in Clause (a) above, on payment of thirty seven paise for every one hundred words or fractional part thereof required to be copied.

Publication of reports of proceeding of general meetings

125. No document purporting to be a report of the proceedings of any general meeting of the Company shall be circulated or advertised at the expenses of the Company unless it includes the matters required by Section 193 of the Act to be contained in the Minutes of the proceedings of such meeting.

MANAGERIAL PERSONNEL

Managerial Personnel

126. The Company shall duly observe the provisions of Section 197A of the Companies Act, 1956 regarding prohibition of simultaneous appointment of different categories of managerial personnel therein referred to.

BOARD OF DIRECTORS

Board of Directors

127. (a) Unless otherwise determined by the Company in General Meeting the number of Directors shall not be less than three and not more than twelve.

Provided further that any increase in the number of Directors exceeding the number prescribed under Section 259 of the Act shall not have any effect unless approved by the Central Government and shall become void if and so far it is disapproved by the Government.

(b). The First Directors of the Company shall be :

- i. Mr. Kaushalkumar S. Gupta
- ii. Ms. Sangeeta K. Gupta
- iii. Mr. Satishkumar S. Gupta

The Directors need not hold any qualification shares.

Appointment of Alternate Director

133. (a) The Board of Directors of the Company may appoint an alternate Director to act for a Director (hereinafter in this Article called "the Original Director") during his absence for a period of not less than three months from the State in which meeting of the Board are ordinarily held.
- (b) An alternate Director appointed under this Article shall not hold office as such for a period longer than that permissible to the Original Director in whose place he has been appointed and shall vacate office if and when the Original Director returns to the State in which meeting of the Board are ordinarily held.
- (c) If the term of office of the Original Director is determined before he returns to the State aforesaid any provision for the automatic reappointment of retiring directors in default of another appointment shall apply to the original and not to the alternate director.

Appointment of Additional Directors

134. Subject to the provisions of Section 161 (to the extent notified) of the Companies Act, 2013, , the Board of Directors shall have power at any time to appoint any person as an additional Director to the Board, but so that the total number of Directors shall not exceed the maximum number fixed by these Articles. Any Director so appointed shall hold the office only upto the next annual general meeting of the Company and shall then be eligible for re-appointment.

Appointment of Director to fill the casual vacancy

135. (a) Subject to the provisions of Section 161 (to the extent notified) of the Companies Act, 2013, if the office of any Director appointed by the Company in general meeting is vacated before his term of office expires in the normal course, the resulting casual vacancy may in default of and subject to any regulation in the Articles of the Company be filled by the Board of Directors at the meeting of the Board and the Director so appointed shall hold office only upto the date upto which the Director in whose place he is appointed would have held office if it had not been vacated as aforesaid but he shall then be eligible for re-election.

Individual Resolution for Directors appointment

(b) At a general meeting of the Company a motion shall not be made for the appointment of two or more persons as Directors of the Company by a single resolution unless a resolution that it shall be so made has first been agreed to by the meeting without any vote being given against it. Resolution moved in contravention of this Article shall be void whether or not objection was taken at the time of its being so moved. Provided that where a resolution so moved is passed no provision for the automatic reappointment of retiring direction by virtue of these Articles and the Act in default of another appointment shall apply.

Appointment of Chairman

136. The Directors may from time to time elect among themselves a chairman of the Board and determine the period for which he is to hold office if at any meeting of the Board, the chairman is not present within fifteen minutes after the time appointed for holding the same, the directors present may choose one of their members to be chairman of the meeting.

Appointment of Chairman Emeritus

137. (1) The Board shall be entitled to appoint any person who has rendered significant or distinguished services to the Company or to the industry to which the Company's business relates or in the public field, as the Chairman Emeritus of the Company.
- (2) The Chairman Emeritus shall hold office until he resigns his office or a special resolution to that effect is passed by the shareholders in a general meeting.
- (3) The Chairman Emeritus may attend any meetings of the Board or Committee thereof but shall not have any right to vote and shall not be deemed to be a party to any decision of the Board or Committee thereof.
- (4) The Chairman Emeritus shall not be deemed to be a director for any purposes of the Act or any other statute or rules made thereunder or these Articles including for the purpose of determining the maximum number of Directors which the Company can appoint.

(5) The Board may decide to make any payment in any manner for any services rendered by the Chairman Emeritus to the Company.

(6) If at any time the Chairman Emeritus is appointed as a Director of the Company, he may, at his discretion, retain the title of the Chairman Emeritus.

Qualification of Director

138. A Director need not hold any shares in the Company to qualify him for the office of a Director of the Company.

Remuneration of Directors

139. (a) Subject to the provisions of the Act, a Managing Director or a Director who is in the wholetime employment of the Company may be paid remuneration either by way of a monthly payment or at a specified percentage of the net profits of the Company or partly by one way and partly by the other.

(b) Subject to the provisions of the Act, a Director, who is neither in the wholetime employment nor a Managing Director may be paid remuneration either :

(i) by way of monthly, quarterly or annual payment with the approval of the Central Government, or

(ii) by way of commission if the Company by a special resolution has authorised such payment.

(c) The fee payable to Directors (other than Managing or Wholetime Director, if any) for attending each meeting of the Board of Committee thereof shall be such sum as may prescribed by the Act or the Central Government from time to time.

Travelling and other expenses

140. The Board may allow and pay to any Director for the purpose of attending a meeting such sum either as fixed allowance and/or actual as the Board may consider fair compensation for travelling, board and lodging and incidental and/or such actual out of pocket expenses incurred by such Director in addition to his fees, for attending such meeting to and from the place at which the meetings of the Board or Committees thereof or general meetings of the Company are held from time to time or any other place at which the Director executes his duties.

Remuneration for extra services

141. If any Director, being willing shall be called upon to perform extra services or to take any special exertions for any of the purposes of the Company and in that event the Company may, subject to the provision of the Act, remunerate such Director either by a fixed sum or by a percentage of profit or otherwise, as may be determined by the Directors but not exceeding that permitted under Section 309 of the Act and such remuneration may be either in addition to or in substitution for his share in the remuneration above provided.

Increase in remuneration of Directors to require Government sanction

142. (a) Any provision relating to the remuneration of any Director including a Managing or Joint Managing or Wholetime Director or any amendment thereof, which purports to increase or has the effect of increasing, whether directly or indirectly, the amount thereof, whether that provision is contained in the Company's Memorandum or there Articles, or in an agreement entered into by it, or any resolution, passed by the Company in general meeting or by the Board of Directors, shall not have any effect unless approved by the Central Government and the amendment shall become void if, and in so far as, it is disapproved by the Government.

Increase in remuneration of Managing Director on re-appointment or appointment

(b) If the terms of any re-appointment of a Managing or Joint Managing or Wholetime Director, purport to increase or have the effect of increasing, whether directly or indirectly, the remuneration which the Managing or Joint Managing or Wholetime Director, as the case may be was receiving immediately before such reappointment or appointment shall not have any effect unless approved by the Central Government, and shall become void if, and in so far as, it is disapproved by the Government.

Directors not to act when number falls below minimum

143. When the number of Directors in Office falls below the minimum above fixed, the Directors, shall not act except in emergencies or for the purpose of filling up vacancies or for summoning a general meeting of the Company and so long as the number is below the minimum they may so act notwithstanding the absence of the necessary quorum.

Duty of Directors etc. to make disclosure

149. (a) Every Director (including a person deemed to be a Director by virtue of the explanation to sub-section (1) of Section 303 of the Act), Managing Director, Manager or Secretary of the Company, who is appointed to or relinquishes the office of Director, Managing Director, Manager or Secretary of any other body corporate shall, within twenty days of his appointment or relinquishment of such office, as the case may be, disclose to the

Company aforesaid the particulars relating to the office in the other body corporate which are required to be specified under sub-section (1) of Section 303 of the Act.

(b) Every Director of the Company and every person deemed to be a Director of the Company by virtue of sub-section (10) of Section 307 of the Act and every other person referred to in sub-section (11) of Section 307 of the Act, shall give notice to the Company of such matters as may be necessary for the purpose of enabling the Company to comply with the provisions of that Section and Section 308 of the Act.

Directors etc. not to hold office or place of profit

150. The provisions of Section 314 of the Act shall be complied with when applicable in regard to holding of office or place of profit under the Company or under any subsidiary of the Company by any person mentioned in the said section. The words office or place of profit shall have the meaning assigned to them by Section 314 of the Act.

Loans to Directors

151. The Company shall observe the restrictions imposed on the Company in regard to granting of loans to Directors and other persons as provided in Section 185 of the Companies Act, 2013 and other applicable provisions, if any of the Act.

ROTATION OF DIRECTORS

Rotation of Directors

154. Not less than two thirds of the total number of Directors shall
- (a) be persons whose period of office is liable to determination by retirement of Directors by rotation, and
 - (b) save as otherwise expressly provided in the Act, be appointed by the Company in general meeting.
- The remaining Directors shall, in default of and subject to any regulations in the Articles of the Company, also be appointed by the Company, in general meeting.

Ascertainment of Directors retiring by rotation and filling up vacancies

155. (a) At every annual general meeting one-third of such of the Directors for the time being as are liable to retire by rotation, or if their number is not three or a multiple of three, then the number nearer to one-third, shall retire from office.
- (b) The Directors to retire by rotation at every annual general meeting shall be those who have been longest in office since their last appointment, but as between persons who became Directors on the same day, those who are to retire shall, in default of and subject to any agreement amongst themselves, be determined by lot.
- (c) At the annual general meeting at which a Director retires as aforesaid, the Company may fill up the vacancy by appointing the retiring Director or some other person thereto.
- (d) (i) If the place of the retiring Director is not so filled up and that meeting has not expressly resolved not to fill the vacancy, the meeting shall stand adjourned till the same day in the next week, at the same time and place, or if that day is a public holiday, till the next succeeding day which is not a public holiday, at the same time and place.
- (ii) If at the adjourned meeting also, the place of the retiring Director is not filled up and that meeting also has not expressly resolved not to fill the vacancy, the retiring Director shall be deemed to have been re-appointed at the adjourned meeting, unless
- (1) at the meeting or at the previous meeting a resolution for the re-appointment of such Director has been put to the meeting and lost;
 - (2) the retiring Director has, by a notice, in writing addressed to the Company or its Board of Directors, expressed his unwillingness to be so re-appointed;
 - (3) he is not qualified or is disqualified for appointment;
 - (4) a resolution, whether special or ordinary, is required for his appointment or re-appointment in virtue of any provisions of the Act; or
- (e) The proviso to sub-section (2) of Section 263 of the Act is applicable to the case.

Explanation: In this Article and Article 156 the expression "Retiring Director" means Director retiring by rotation.

PROCEEDINGS OF DIRECTORS

Meeting of Directors

158. The directors may meet together as a Board for the dispatch of business from time to time and shall so meet at least once in every three months and at least four such meetings shall be held in every year and they may adjourn and otherwise regulate their meetings and proceedings as they deem fit. The provisions of this Article shall not be deemed to be contravened merely by reason of the fact that meetings of the Board which had been called in compliance with the terms herein mentioned could not be held for want of quorum.

When meeting to be convened

159. Any Director of the Company may and the Manager or Secretary on the requisition of a Director shall, at any time, summon a meeting of the Board.

Directors entitled to notice

160. Notice of every meeting of the Board of the Company shall be given in writing to every Director for the time being in India and at his usual address in India.

Question at Board meeting how decided

161. Question arising at any time at a meeting of the Board shall be decided by majority of votes and in case of equality of votes, the Chairman, in his absence the Vice Chairman or the Director presiding shall have a second or casting vote.

Who to preside at meetings of the Board

162. (a) The Directors may elect a Chairman of their meeting and determine the period for which he is to hold office. The Directors may also appoint a Vice Chairman of the Board of Directors to preside at the meetings of the Board of Directors at which the Chairman shall not be present and determine the period for which he is to hold office.

(b) All the meetings of the Directors shall be presided over by the Chairman, if present, but if at any meeting of Directors the Chairman be not present at the time appointed for holding the same, the Vice Chairman, if present, shall preside and if he be not present at such time then and in that case the Directors shall choose one of the Directors then present to preside at the meeting.

Quorum at Board Meeting

163. (a) The quorum at a meeting of the Directors shall be as prescribed by Section 287 of the Act.
(b) Quorum competent to exercise power

A meeting of the Directors for the time being at which a quorum is present shall be competent to exercise all or any of the authorities, powers and discretions by or under the regulations or the Articles of the Company for the time being vested in or exercisable by the Directors generally.

(c) Procedure in case of want of quorum

If a meeting of the Board could not be held for want of quorum, then the meeting shall automatically stand adjourned till the same day in the next week, at the same time and place, or if that day is a Public Holiday, till the next succeeding day which is not a public holiday, at the same time and place.

Directors may appoint committee

164. Subject to the provisions of Section 292 and other provisions of the Act and Article 165 the Directors may delegate all or any of their powers to committees consisting of such member or members of their body as they think fit, and they may, from time to time revoke and discharge any such Committee either wholly or in part, and either as to persons or purposes, but every Committee so formed shall in the exercise of the powers so delegated, conform to any regulations that may from time to time be imposed on it by the Directors. All acts done by any such Committee in conformity with such regulations and in fulfillment of the purposes of their appointments but not otherwise, shall have the like force and effect as if done by the Board. Subject to the provisions of the Act the Board may from time to time fix the remuneration to be paid to any member or members of that body constituting a Committee appointed by the Board in terms of these Articles, and may pay the same.

Resolution by circular

165. Subject to the provisions of Section 289 of the Act, a resolution passed without any meeting of Directors, or of a Committee of Directors appointed under these Articles and evidenced by writing under the hands of all the Directors or members of such Committee as aforesaid, for the time being in India, be as valid and effectual as a resolution duly passed at a meeting of the Directors or of such committee called and held in accordance with the provisions of these Articles.

Provided that the resolution has been circulated in draft, together with the necessary papers, if any, to such Directors, or members of the Committee, then in India (not being less in number than the quorum fixed for a meeting of the Board or the Committee as the case may be) and all other Directors or members at their usual address in India and has been approved by such Directors as are then in India or by majority of such of them, as are entitled to vote on the resolution.

Acts of Board or Committee valid notwithstanding defect of appointment

167. All acts done by any meeting of the Directors or by a Committee of Directors, or by any person acting as a Director, shall notwithstanding that it shall afterwards be discovered that there was some defect in the appointment of such Directors or persons acting as aforesaid, or they or any of them were or was disqualified or that their or his appointment had terminated by virtue of any provisions contained in these Articles or the Act, be as valid as if every such person has been duly appointed and was qualified to be a Director.

Minutes of proceedings of the Board and the Committees to be valid

168. The Directors shall cause minutes to be duly entered in a book or books provided for the purpose in accordance with these Articles and Section 193 of the Companies Act, 1956.

Board Minutes to be evidence

169. Minutes of any meeting of the Board of Directors or of any Committees of the Board if purporting to be signed by the Chairman of such meeting or by the Chairman of the next succeeding meeting shall be for all purposes whatsoever prima facie evidence of the actual passing of the resolution recorded and the actual and regular transaction or occurrence of the proceedings so recorded and the regularity of the meeting at which the same shall appear to have taken place.

Register of Directors and Managing Directors etc.

170. The Directors shall cause to be kept at the registered office of the Company :
- (a) (i) A Register of the Directors, Managing Directors, Manager and Secretary of the Company containing the particulars required by Section 303 of the Act.
 - (ii) A Register of Contracts with companies and firms in which the Directors are interested, containing the particulars required by Section 301 of the Act, and
 - (iii) A Register of Directors shareholding containing the particulars required by Section 307 of the Act. They shall also cause to be kept other registers and indexes as required by the Act.
- (b) The Company shall comply with the provisions of Sections 301, 303 and 307 and other Section of the Act with regard to the inspection of registers and furnishing copies or extracts so far as the same be applicable to the Company.

POWERS OF DIRECTORS

Certain powers to be exercised by the Board only at meeting

171. (a) Without derogating from the powers vested in the Board of Directors under these Articles, the Board shall exercise the following powers on behalf of the Company and they shall do so only by means of resolutions passed at meetings of the Board.
- (i) The power to make calls on shareholders in respect of money unpaid on their shares;
 - (ii) The power to issue debenture;
 - (iii) The power to borrow moneys otherwise than on debentures;
 - (iv) The power to invest the funds of the Company, and
 - (v) The power to make loans.

Provided that the Board may by resolution passed at the meeting, delegate to any Committee of Directors, the Managing Director, the Manager or any other principal officer of the Company or in the case of a branch office of the Company, a principal officer of the branch office, the powers specified in sub-clauses (iii), (iv) and (v) to the extent specified in clauses (b), (c) and (d) respectively on such condition as the Board may prescribe.

(b) Every resolution delegating the power referred to in sub-clause (iii) of clause (a) shall specify the total amount outstanding at any one time up to which moneys may be borrowed by the delegate.

(c) Every resolution delegating the power referred to in sub-clause (iv) of clause (a) shall specify the total amount up to which the funds of the Company may be invested and the nature of the investments which may be made by the delegate.

(d) Every resolution delegating the power referred to in sub-clause (v) of clause (a) shall specify the total amount up to which loans may be made by the delegates, the purposes for which the loans may be made and the maximum amount up to which loans may be made for each such purpose in individual cases.

(e) Nothing in this Article shall be deemed to affect the right of the Company in general meeting to impose restrictions and conditions on the exercise by the Board of any of the powers referred to in sub-clauses (i), (ii), (iii), (iv) and (v) of clause (a) above.

Restriction on powers of Board

172. (a) The Board of Directors of the Company shall not except with the consent of the Company in general meeting :

- (i) sell, lease or otherwise dispose of the whole, or substantially the whole, of the undertaking of the Company, or where the Company owns more than one undertaking of the whole or substantially the whole of any such undertaking;
 - (ii) remit, or give time for the repayment of any debt, due by a Director;
 - (iii) invest, otherwise than in trust securities, the amount of compensation received by the Company in respect of the compulsory acquisition of any such undertaking as is referred to in sub-clause (i) above, or of any premises or properties used for any such undertaking and without which it cannot be carried on or can be carried on only with difficulty or only after a considerable time;
 - (iv) borrow moneys, where the money to be borrowed, together with the moneys already borrowed by the Company (apart from the temporary loans obtained from the Company's bankers in the ordinary course of business) will exceed the aggregate of the paid-up capital of the Company and its free reserves that is to say, reserves not set apart for any specific purpose; or
 - (v) contribute to charitable and other funds not directly relating to the business of the Company or the welfare of its employees any amounts the aggregate of which will in any financial year, exceed fifty thousand rupees or five percent of its average net profits as determined in accordance with the provisions of Sections 349 and 350 of the Act during the three financial years, immediately proceedings, whichever is greater.
- (b) Nothing contained in sub-clause (a) above shall affect:
- (i) the title of a buyer or other person who buys or takes a lease of any such undertaking as is referred to in that sub-clause in good faith and after exercising due care and caution, or
 - (ii) the selling or leasing of any property of the Company where the ordinary business of the Company consists of, or comprises such selling or leasing.
- (c) Any resolution passed by the Company permitting any transaction such as is referred to in sub-clause (a) (i) above, may attach such conditions to the permission as may be specified in the resolution, including conditions regarding the use, disposal or investment of the sale proceeds which may result from the transaction. Provided that this clause shall not be deemed to authorise the Company to effect any reduction in its capital except in accordance with the provisions contained in that behalf in the Act.
- (d) No debt incurred by the Company in excess of the limit imposed by sub-clause (iv) of clause (a) above, shall be valid or effectual, unless the lender proves that he advanced the loan in good faith and without knowledge that the limit imposed by that clause had been exceeded.

Prohibition regarding making of political contributions

- (e) Due regard and compliance shall be observed in regard to matters dealt with by or in the Explanation contained in sub-section (1) of Section 293 of the Companies Act, 1956 & Section 180 of the Companies Act, 2013 and in regard to the limitations on the power of the Company contained in Section 293A of the Companies Act, 1956 & Section 182 of the Companies Act, 2013.

General powers of the Company vested in Directors

173. Subject to the provisions of the Act, the management of the business of the Company shall be vested in the Directors and the Directors may exercise all such powers and do all such acts and things as the Company is by the Memorandum of Association or otherwise authorised to exercise and do and not hereby or by the statute or otherwise directed or required to be exercised or done by the Company in General Meeting, but subject nevertheless to the provisions of the Act and other Act and of the Memorandum of Association and these Articles and to any regulations, not being inconsistent with the Memorandum of Association and these Articles or the Act, from time to time made by the Company in general meeting provided that no such regulation shall invalidate any prior act of the Directors which would have been valid if such regulation had not been made.

Specific powers given to Directors

174. Without prejudice to the general powers conferred by Article 172 and the other powers conferred by these presents and so as not in any way to limit any or all of those powers, it is hereby expressly declared that the Directors shall have the following powers:

To pay registration expense

- (i) to pay the costs, charges and expenses preliminary and incidental to the promotion, formation, establishment and registration of the Company;
- (ii) to pay and charge to the capital account of the Company and interest lawfully payable thereon under the provisions of Sections 76 corresponding to Section 40 of the Companies Act, 2013 and 208 of the Companies Act, 1956;

To acquire property

- (iii) Subject to the provisions of the Act and these Articles to purchase or otherwise acquire any lands, buildings, machinery, premises, hereditaments, property effects, assets, rights, credits, royalties, bounties and goodwill of any person, firm or Company carrying on the business which this Company is authorised to carry on,

at or for such price or consideration and generally on such terms and conditions as they may think fit; and in any such purchase or acquisition to accept such title as the Board may believe or may be advised to be reasonable satisfactory;

To purchase lands, buildings etc.

(iv) Subject to the provisions of the Act to purchase, or take on lease for any term or terms of years, or otherwise acquire any mills or factories or any land or lands, with or without buildings and outhouses thereon, situate in any part of India, at such price or rent and under and subject to such terms and conditions as the Directors may think fit; and in any such purchase, lease or other acquisition to accept such title as the Directors may believe or may be advised to be reasonably satisfactory;

To construct buildings

(v) To erect, construct, enlarge, improve, alter, maintain, pull down rebuilt or reconstruct any buildings, factories, offices, workshops or other structures, necessary or convenient for the purposes of the Company and to acquire lands for the purposes of the Company;

To mortgage, charge property

(vi) To let, mortgage, charge, sell or otherwise dispose of subject to the provisions of Section 293 of the Companies Act, 1956 and Section 180 of the Companies Act, 2013 any property of the Company either absolutely or conditionally and in such manner and upon such terms and conditions in all respects as they think fit and to accept payment or satisfaction for the same in cash or otherwise, as they may think fit;

To pay for property etc.

(vii) At their discretion to pay for any property, rights or privileges acquired by or services rendered to the Company, either wholly or partially, in cash or in shares, bonds, debentures, debenture stock or other securities of the Company, and any such shares may be issued either as fully paid up or with such amount credited as paid up thereon as may be agreed upon; and any such bonds, debentures, debenture stock or other securities may be either specifically charged upon all or any part of the property of the Company and its uncalled capital or not so charged;

To Insure

(viii) To insure and keep insured against loss or damage by fire or otherwise, for such period and to such extent as they may think proper, all or any part of the building, machinery, goods, stores, produce and other moveable property of the Company either separately or co-jointly; also to insure all or any portion of the goods, produce, machinery and other articles imported or exported by the Company and to sell, assign, surrender or discontinue any policies of assurance effected in pursuance of this power;

To open accounts

(ix) Subject to Section 292 of the Companies Act, 1956 to open accounts with any bank or bankers or with any Company, firm, or individual and to pay money into and draw money from any account from time to time as the Directors may think fit;

To secure contracts

(x) To secure the fulfillment of any contracts or engagements entered into by the Company by mortgage or charge of all or any of the properties of the Company and its unpaid capital for the time being or in such other manner as they may think fit;

To attach to Shares such conditions

(xi) To attach to any shares to be issued as the consideration for any contract with or property acquired by the Company, or in payment for services rendered to the Company, such conditions, subject to the provisions of the Act, as to the transfer thereof as they may think fit;

To accept surrender, of shares

(xii) To accept from any member on such terms and conditions as shall be agreed, a surrender of his shares or stock or any part thereof subject to the provisions of the Act;

To appoint trustees

(xiii) To appoint any person or persons (whether incorporated or not) to accept and hold in trust for the Company any property belonging to the Company or in which it is interested or for other purposes and to execute and do all such deeds and things as may be requisite in relation to any such trusts and to provide for the remuneration of such trustee or trustees;

To bring and defend actions

(xiv) To institute, conduct, defend, compound or abandon any legal proceedings by or against the Company or its Officers or otherwise concerning the affairs of the Company and also subject to the provisions of Section 293 of the Companies Act, 1956 and Section 180 of Companies Act, 2013 to compound and allow time for payment or satisfaction of any debts due, or of any claims or demands by or against the Company;

To refer to arbitration

(xv) To refer, subject to the provisions of Section 293 of the Companies Act, 1956 and Section 180 of the Companies Act, 2013 any claims or demands by or against the Company to arbitration and observe and perform the awards;

To act on insolvency matters

(xvi) To act on behalf of the Company in all matters relating to bankrupts and insolvents;

To give receipts

(xvii) To make and give receipts, releases and other discharges for moneys payable to the Company and for the claims and demands of the Company subject to the provisions of Section 293 of the Companies Act, 1956 and Section 180 of the Companies Act, 2013.

To authorise acceptances

(xviii) To determine from time to time as to who shall be entitled to sign bills, notes, receipts, acceptances, endorsements, cheques, dividend warrants, releases, contracts and documents on the Company's behalf;

To invest moneys

(xix) Subject to the provisions of Sections 292, 293, 372A of the Companies Act, 1956 and Section 180 of the Companies Act, 2013 to invest and deal with any of the moneys of the Company, not immediately required for the purpose thereof, upon such Shares, securities or investments (not being Shares in this Company) and in such manner as they may think fit, and from time to time to vary or realize such investments.

To provide for personal liabilities

(xx) To execute in the name and on behalf of the Company in favour of any Director or other person who may incur or be about to incur any personal liability for the benefit of the Company, such mortgages of the Company's property (present and future) as they may think fit and any such mortgage may contain a power of sale and such other powers, covenants and provisions as shall be agreed on;

To give to Directors etc. an interest in business

(xxi) Subject to such sanction as may be necessary under the Act or these Articles, to give any Director, Officer, or other person employed by the Company, an interest in any particular business or transaction either by way of commission on the gross expenditure thereon or otherwise or a share in the general profits of the Company, and such interest, commission or share of profits shall be treated as part of the working expenses of the Company.

To provide for welfare of employees

(xxii) To provide for the welfare of employees or ex-employees of the Company and their wives, widows, families, dependants or connections of such persons by building or contributing to the building of houses, dwelling, or chawls or by grants of money, pensions, allowances, gratuities, bonus or payments by creating and from time to time subscribing or contributing to provident and other funds, institutions, or trusts and by providing or subscribing or contributing towards places of instruction and recreation, hospitals and dispensaries, medical and other attendances and other assistance as the Directors shall think fit;

To subscribe to charitable and other funds

(xxiii) Subject to the provisions of the Act, to subscribe, or contribute or otherwise to assist or to guarantee money to charitable, benevolent, religious, scientific, national public or any other useful institutions, object or purposes for any exhibition;

To maintain pension funds

(xxiv) To establish and maintain or procure the establishment and maintenance of any contributory or non contributory pension or superannuation funds for the benefit of, and give or procure the giving of donations, gratuities, pensions, allowances or emoluments, to any persons who are or were at any time in the employment or services of the Company, or of any Company which is a subsidiary of the Company or is allied to or associated with the company or with any such subsidiary company, or who are or were at anytime Directors or officers of the company or of any such other Company as aforesaid, and the wives, widows, families and dependants of any such persons and, also to establish and subsidize and subscribe to any institution, association, clubs or funds collected to be for the benefit of or to advance the interests and well being of the Company or of any such other Company as aforesaid, and make payments to or towards the insurance of any such person as aforesaid and do any of the matters aforesaid, either alone or in conjunction with any such other Company as aforesaid;

(xxv) To decide and allocate the expenditure on capital and revenue account either for the year or period or spread over the years.

To Create Reserve Fund

(xxvi) Before recommending any dividend, to set aside out of profits of the Company such sums as they may think proper for depreciation or to Depreciation Fund or Reserve Fund or Sinking Fund or any other special fund to meet contingencies or to repay redeemable preference shares, debentures, or debenture stock or for special dividend or for equalising dividend for repairing, improving, extending and maintaining any part of the property of the Company, and for such other purposes as the Directors may, in their absolute discretion, think conducive to the interests of the Company and to invest the several sums so set aside or so much thereof as required to be invested upon such investments (subject to the restrictions imposed by Sections 292 and 293 and other provisions of the Companies Act 1956 and Section 180 of the Companies Act, 2013) as the directors may think fit, and from time to time, to deal with and vary such investments and dispose of and apply and expend all or any part thereof for the benefit of the Company in such manner and for such purpose as the Directors (subject to such restrictions

as aforesaid) in their absolute discretion think conducive to the interests of the Company notwithstanding that the matters to which the Directors apply or upon which they may expend the same or any part thereof may be matters to or upon which the capital moneys of the Company might rightly be applied or expended; and to divide the Reserve Fund into such special funds as the Directors think fit, and to employ the assets constituting all or any of the above funds, including the Depreciation Fund, in the business of the Company or in repayment or redemption or redeemable preference shares, debentures or debenture stock and that without being bound to keep the same separate from other assets or to pay interest on the same, with power, however to the Directors at their discretion, to pay or allow to the credit of such fund interest at such rate as the Directors may think proper.

To appoint Managers etc.

(xxvii) To appoint and at their discretion to remove or suspend such Managers, Secretaries, Officers, Clerks, Agents and servants for permanent, temporary or special service as they may from time to time think fit, and to determine their powers and duties, and fix their salaries or emoluments and require security in such instances and to such amounts as they may think fit, and from time to time to provide for the management and transactions of the affairs of the Company in any special locality in India in such manner as they may think fit. The provisions contained in the clause following shall be without prejudice to the general powers conferred by this clause.

To authorise by power of attorney

(xxviii) At any time and from time to time by power of attorney to appoint any person or persons to be the Attorney or Attorneys of the Company for such purposes and with such powers, authorities and discretions (not exceeding those vested in or exercisable by the Directors under these presents) and for such period and subject to such conditions as the Directors may from time to time think fit and any such appointment (if the Directors may think fit) be made in favour of any Company or the members, directors, nominees or managers of any Company or firm or otherwise in favour of any fluctuating body or person whether nominated, directly or indirectly by the Directors and such power of attorney may contain any such powers for the protection or convenience of persons dealing with such Attorneys as the Directors may think fit; and may contain powers enabling any such delegates or Attorneys as aforesaid to sub-delegate all or any of the powers, authorities, and discretion for the time being vested in them.

To authorise, delegate

(xxix) Subject to the provisions of the Act, generally and from time to time and at any time to authorise, empower or delegate to (with or without powers of sub-delegation) any Director, Officer or Officers or Employees for the time being of the Company and/or any other person, firm or Company all or any of the powers, authorities and discretions for the time being vested in the Directors by these presents, subject to such restrictions and conditions, if any as the Directors may think proper.

To Negotiate

(xxx) To enter into all such negotiations, contracts and rescind and/or vary all such contracts and to execute and do all such acts, deeds, and things in the name of on behalf of the Company as they may consider expedient for or in relation to any of the matters aforesaid or otherwise for the purposes of the Company.

MANAGING DIRECTORS

Power to appoint Managing or Wholtime Directors

175. (a) Subject to the provisions of the Act and of these Articles the Board shall have power to appoint from time to time any of its members as Managing Director or Managing Directors and/or Wholtime Directors and/or Special Director like Technical Director, Financial Director, etc. of the Company for a fixed term not exceeding five years at a time and upon such terms and conditions as the Board thinks fit, and the Board may by resolution vest in such Managing Director or Managing Directors/Wholtime Director(s), Technical Director(s), Financial Director(s) and Special Director(s) such of the power hereby vested in the Board generally as it thinks fit, and such powers may be made exercisable for such period or periods, and upon such condition and subject to such restriction as it may determine, the remuneration of such Directors may be way of monthly remuneration and/or fee for each meeting and/or participation in profits, or by any or all of those modes, or of any other mode not expressly prohibited by the Act.

Appointment and payment of remuneration to Managing or Wholtime Director

- (b) Subject to the provisions of Sections 198, 269, 309, 310 and 311 of the Act, the appointment and payment of remuneration to the above Director shall be subject to approval of the members in general meeting and of the Central Government.

THE SECRETARY

Secretary

176. Subject to the provisions of Section 383 A of the Act, the Directors may, from time to time, appoint and, at their discretion remove any individual (hereinafter called "the Secretary") who shall have such Qualifications as the authority under the Act may prescribe to perform any functions, which by the Act or these Articles are to be

performed, by the Secretary, and to execute any other purely ministerial or administrative duties which may from time to time be assigned to the Secretary by the Director. The Directors may also at any time appoint some persons (who need not be the Secretary) to keep the registers required to be kept by the Company.

SEAL

The seal its custody and use

177. (a) The Directors shall provide a Common Seal for the purpose of the Company and shall have power from time to time to destroy the same and substitute a new Seal in lieu thereof, and the Directors shall provide for the safe custody of the Seal for the time being and the Seal shall never be used except by or under the authority of the Directors or a Committee of the Directors previously given, and in the presence of one Director or a Committee of the Directors previously given, and in the presence of one Director at the least, who shall sign every instrument to which the Seal is so affixed in his presence.

(b) Seal abroad

The Company shall also be at liberty to have an official seal in accordance with Section 50 of the Act for use in any territory, district or place outside India and such powers shall accordingly be vested in the Directors.

INTEREST OUT OF CAPITAL

Interest may be paid out of Capital

178. Where any shares in the Company are issued for the purpose of raising money to defray the expenses of the construction of any work or building, or the provisions of any plant, which cannot be made profitable for a lengthy period, the Company may pay interest on so much of that share capital as is for the time being paid up, for the period and at the rate and subject to the conditions and restrictions provided by Section 208 of the Act, and may charge the same to capital as part of the cost of construction of the work or building, or the provisions of plant.

DIVIDENDS

Division of Profits

179. The profits of the Company subject to any special rights relating thereto created or authorised to be created by these presents shall be divisible among the members in proportion to the amount of Capital paid up or credited as paid up on the shares held by them respectively.

Dividend payable to registered holder

180. No dividend shall be paid by the Company in respect of any share except to the registered holder of such share or to his order or to his banker.

Time of payment of dividend

181. Where a dividend has been declared by the Company it shall be paid within the period provided in Section 207 of the Act.

Capital paid up in advance and interest not to earn dividend

182. Where the Capital is paid up in advance of calls upon the footing that the same shall carry interest, such Capital shall not, whilst carrying interest confer a right to dividend or to participate in profits.

Dividends in proportion to amount paid up

183. (a) The Company shall pay dividends in proportion to the amounts paid up or credited as paid up on each share, when a larger amount is paid up or credited as paid up on some shares than on others. Nothing in this Article shall be deemed to affect in any manner the operation of Section 208 of the Act.
(b) Provided always that any Capital paid up on a share during the period in respect of which a dividend is declared, shall unless the terms of issue otherwise provide, only entitle the holder of such share to an apportioned amount of such dividend proportionate to the capital from time to time paid during such period on such share.

Company in General Meeting may declare dividends

184. The Company in general meeting may declare a dividend to be paid to the members according to their respective rights and interests in the profits and may fix the time for payment.

Power of Directors to limit dividend

185. No larger dividend shall be declared than is recommended by the Directors but the Company in general meeting may declare a smaller dividend.

Dividends only to be paid out of profits

186. No dividend shall be declared or paid by the Company otherwise than out of profits of the financial year arrived at after providing for depreciation in accordance with the provisions of sub-section (2) of Section 205 of the Act or out of the profits of the Company for any previous financial year or years arrived at after providing for depreciation in accordance with these provisions and remaining undistributed or out of both or out of moneys provided by the Central Government or a State Government for the payment of dividend in pursuance of the guarantee given by that Government provided that:

(a) If the Company has not provided for depreciation for any previous financial year or years, it shall before declaring or paying a dividend for any financial year, provide for such depreciation out of the profits of that financial year or out of the profits of any other previous financial year or years;

(b) If the Company has incurred any loss in any previous financial year or years the amount of the loss or an amount which is equal to the amount provided for depreciation for that year or those years whichever is less, shall be set off against the profits of the Company for the year for which the dividend is proposed to be declared or paid or against the profits of the Company for any previous financial year or years arrived at in both cases after providing for depreciation in accordance with the provisions of sub-section (2) of Section 205 of the Act or against both.

Provided further that, no dividend shall be declared or paid for any financial year out of the profits of the Company for that year arrived at after providing for depreciation as above, except after the transfer to the reserves of the Company of such percentage of its profits for that year as may be prescribed in accordance with Section 205 of the Act or such higher percentage of its profits as may be allowed in accordance with that Section.

Nothing contained in this Article shall be deemed to affect in any manner the operation of Section 208 of the Act.

Directors' declaration as to net profits conclusive

187. The declaration of the Directors as to the amount of the net profits of the Company shall be conclusive.

Interim Dividends

188. The Directors may, from time to time, pay to the members such interim dividends as in their judgement the position of the Company justifies.

Retention of Dividend until completion of transfer under Article

189. The Directors may retain the Dividends payable upon shares in respect of which any person is under the Transmission clause of these Articles entitled to become a member or which any person under the clause is entitled to transfer until such person shall become a member in respect of such shares or shall duly transfer the same.

No member to receive Dividend whilst indebted to the Company and Company's right to reimbursement therefrom

190. Subject to the provisions of the Act, no member shall be entitled to receive payment of any interest or dividend in respect of his share(s) whilst any money may be due or owing from him to the Company in respect of such share(s) or debenture(s) or otherwise however either alone or jointly with any other person or persons and the Directors may deduct from the interest or dividend payable to any member, all sums of moneys so due from him to the Company.

Transferred shares must be registered

191. A transfer of shares shall not pass the right to any dividend declared thereon before the registration of the transfer.

Dividend how remitted

192. Unless otherwise directed any dividend may be paid by cheque or warrant or a pay-slip or receipt having the force of a cheque or warrant sent through ordinary post to the registered address of the member or person entitled or in the case of joint holders to that one of them first named in the Register of Members in respect of the joint holding. Every such cheque or warrant so sent shall be made payable to the registered holder of shares or to his order or to his bankers. The Company shall not be liable or responsible for any cheque or warrant lost in transmission or for any dividend lost, to the member or person entitled thereto by the forged endorsement of any cheque or warrant or the fraudulent or improper recovery thereof by any other means.

Unpaid or Unclaimed Dividend

193. (a) Where the Company has declared a dividend but which has not been paid or claimed within 30 days from the date of declaration, transfer the total amount of dividend which remains unpaid or unclaimed within the said period of 30 days, to a special account to be opened by the company in that behalf in any scheduled bank, to be called “_____ Unpaid Dividend Account”
- (b) The company shall transfer any money transferred to the unpaid dividend account of a company that remains unpaid or unclaimed for a period of seven years from the date of such transfer, to the Fund known as Investor Education and Protection Fund established under section 205C of the Act.

Dividend and call together

194. Any general meeting declaring a dividend may on the recommendation of the Directors make a call on the members for such amount as the meeting fixes, but so that the call on each member shall not exceed the dividend payable to him so that the call be made payable at the same time as the dividend and the dividend may, if so arranged between the Company and the members, be set off against the calls.

Dividend to be payable in cash

195. No dividend shall be payable except in cash. Provided that nothing in this Article shall be deemed to prohibit the capitalisation of profit or reserves of the Company for the purpose of issuing fully paid up bonus shares or paying up any amount for the time being unpaid on any shares held by the members of the Company.

ACCOUNTS

Books of Accounts to be kept

199. (a) The Company shall keep at its Registered Office proper books of accounts as required by Section 209 of the Act with respect to :
- (i) all sums of money received and expended by the Company and the matters in respect of which the receipt and expenditure take place;
 - (ii) all sales and purchases of goods by the Company; and
 - (iii) the assets and liabilities of the Company;

Provided that all or any of the books of account aforesaid may be kept at such other place in India as the Board of Directors may decide and when the Board of Directors so decide, the Company shall, within seven days of the decision file with the Registrar a notice in writing giving the full address of that other place.

(b) If the Company shall have a branch office, whether in or outside India, proper books of account relating to the transactions effected at that office shall be kept at that office and proper summarised returns made up to date at intervals of not more than three months, shall be sent by the branch office to the Company at its Registered Office or other place in India, as the Board thinks fit, where the said books of the Company are kept.

Books to give fair and true view of the Company's affairs

200. (a) All the aforesaid books shall give a fair and true view of the affairs of the Company or of its branch office, as the case may be with respect to the matters aforesaid, and explain the transactions.
- (b) The books of account shall be open to inspection by any Director during business hours as provided by Section 209 of the Act.
- (c) The books of account of the Company relating to a period of not less than eight years immediately preceding the current year together with the vouchers relevant to any entry in such books of accounts shall be preserved in good order.

Inspection by members

201. The Directors shall from time to time determine whether and to what extent and at what times and places and under what conditions or regulations the accounts, books and documents of the Company or any of them, shall be open to the inspection of the members, and no member (not being a Director) shall have any right of inspecting any account or books or documents of the Company except as conferred by statute or authorised by the Directors or by a resolution of the Company in general meeting.

Statements of Accounts to be furnished to General Meeting

202. The Board of Directors shall lay before each annual general meeting a Profit and Loss Account for the financial year of the Company and a Balance Sheet made up as at the end of the financial year which shall be a date, which shall not precede the day of the meeting by more than six months or such extended period as shall have been granted by the Registrar of Companies under the provisions of the Act.

Balance Sheet and Profit and Loss Account

203. (a) Subject to the provisions of Section 211 of the Companies Act, 1956 and Section 133 of Companies Act, 2013 every Balance Sheet and Profit and Loss Account of the Company shall be in the forms set out in parts I and II respectively of Schedule VI of the Act, or as near thereto as circumstances admit. There shall be annexed to every Balance Sheet a statement showing the bodies corporate (indicating separately the bodies corporate in the same group) in the shares of which investments have been made by it (including all investments, whether existing or not, made subsequent to the date as at which the previous Balance Sheet was made out) and the nature and extent of the investments so made in each body corporate.
- (b) So long as the Company is a holding Company having a subsidiary the Company shall conform to Section 212 and other applicable provisions of the Act.
- (c) If in the opinion of the Board, any of the current assets of the Company have not a value on realisation in the ordinary course of business at least equal to the amount at which they are stated, the fact that the Board is of that opinion shall be stated.

Right of Members to copies of Balance Sheet and Auditor's Report

207. A copy of every Balance Sheet (including the Profit and Loss Account, the Auditor's Report and every other document required by Law to be annexed or attached as the case may be, to the Balance Sheet) which is to be laid before the Company in General Meeting shall be made available for inspection at the Registered Office of the Company during working hours for a period of twenty one days before of the meeting.

Three copies of Balance Sheet etc. to be filed with Registrar

208. After the Balance Sheet and Profit and Loss Account have been laid before the Company at the annual general meeting, three copies of the Balance Sheet and Profit and Loss Account duly signed as provided under Section 220 of the Act together with three copies of all documents, which are required to be annexed thereto shall be filed with the Registrar, so far as the same be applicable to the Company.

AUDIT

Accounts to be audited

209. Every Balance Sheet and Profit and Loss Account shall be audited by one or more Auditors to be appointed as hereinafter mentioned.

Appointment and qualification of auditors

210. (a) The Company at the annual general meeting each year shall appoint an Auditor or Auditors to hold office from the conclusion of that meeting until the conclusion of the next annual general meeting, and shall, within seven days of the appointment, give intimation thereof to every auditor so appointed.

Remuneration of Auditors

212. The remuneration of the Auditors shall be fixed by the Company in general meeting in such manner as the Company may in general meeting determine except that the remuneration of any Auditors appointed to fill any casual vacancy may be fixed by the Directors.

DOCUMENTS AND NOTICES

Service of Notice by member

215. A notice may be served on the Company or an Officer thereof by sending it to the Company or Officer at the Registered Office of the Company by post under a Certificate or posting or by registered post or by leaving it at its Registered Office.
- The term "Notice" in this and the following clauses shall include summons, notice, requisition, order, judgement or other legal papers and any document.

Service of Notice on Register

216. A notice may be served on the Registrar by sending it to him at his office by post under a certificate of posting or by registered post, or by delivering it to, or leaving it for him at his office.

Service of Notice on member by the Company

217. (a) A Notice may be served by the Company on any member either personally or by sending it by post to him to his registered address or if he has no registered address in India to the address, if any, within India supplied by him to the Company for giving Notice to him.
- (b) Where a Notice is sent by post:

- (i) Service thereof shall be deemed to be effected by properly addressing prepaying and posting a letter containing the document, provided that, where a member has intimated to the Company in advance that documents should be sent to him under a certificate of posting or by registered post with or without acknowledgment due, and has deposited with the Company a sum sufficient to defray the expenses of doing so, service of the document shall not be deemed to be effected unless it is sent in the manner intimated by the member; and
- (ii) Such service shall be deemed to have been effected:
 - (1) in the case of a Notice of a meeting at the expiration of forty eight hours after the letter containing the same is posted, and
 - (2) in any other case, at the time at which the letter would be delivered in the ordinary course of post.

By Advertisement

(c) A Notice advertised in a newspaper circulating in neighbourhood of the registered office of the Company shall be deemed to be duly served on the day on which the advertisement appears on every member of the Company who has no registered address in India and has not supplied to the Company an address within India for the giving of Notice to him.

On joint holder

(d) Any notice may be served by the Company on the Joint-holders of a Share/debenture by serving it on the joint holder named first in the Register of member / debenture holders in respect of the share/debenture.

On Personal Representative

(e) A Notice may be served by the Company on the person entitled to a share in consequence of the death or insolvency of a member by sending it through the post in a prepaid letter addressed to them by name, or by the title representatives of the deceased or assignees of the insolvent or by any like description, at the address, if any in India supplied for the purpose by the persons claiming to be so entitled, or until such an address has been so supplied, by serving the document in any manner in which it might have been served if the death or insolvency had not occurred.

Notice by Company and signatures thereto

218. Any Notice given by the Company shall be signed by a Director, or by such Officer as the Directors may appoint and the signatures thereto may be written printed or lithographed.

Authentication of documents and proceedings

219. Save as otherwise expressly provided in the Act, a document or proceedings requiring authentication by the Company may be signed by the director, the Managing Director, the Manager, the Secretary or other authorized Officer of the Company and need not be under its Common Seal

WINDING UP

Distribution of Assets

220. (a) Subject to the provisions of the Act, if the Company shall be would up and the assets available for distribution among the members as such shall be less than sufficient to repay the whole of the paid up capital such assets shall be distributed so that, as nearly, as may be, the losses shall be borne by the members in proportion to the Capital paid up, or which ought to have been paid up, at the commencement of winding up, on the shares held by them respectively. And if in winding up, the assets available for distribution among the members shall be more than sufficient to repay the whole of the Capital paid up at the commencement of the winding up the excess shall be distributed amongst the members in proportion to the Capital paid-up at the commencement of the winding up or which ought to have been paid up on the shares held by them respectively.
- (b) But this clause will not prejudice the rights of the holders of shares issued upon special terms and conditions.

Rights of shareholders in case of sale

222. Subject to the provisions of the Act, a special resolution sanctioning a sale to any other Company duly passed may, in like manner as aforesaid, determine that any shares or other consideration receivable by the Liquidators be distributed amongst the members otherwise than in accordance with their existing rights and any such determination shall be binding upon all the members subject to the rights of dissent, if any, if such right be given by the Act.

SECRECY CLAUSE

223. (a) Every Director, Manager, Auditor, Treasurer, Trustee, Member of a Committee, Officer, Servant, Agent, Accountant or other person employed in the business of the Company shall if so required by the Directors, before entering upon his duties, sign a declaration pledging himself to observe a strict secrecy respecting all transactions and affairs of the Company with the customers and the state of accounts with individuals and in matters thereto, and shall by such declaration pledge himself not to reveal any of the matters which may come to this knowledge in the discharge of his duties except when required so to do by the Directors or by law or by the person to whom such matters relate and except so far as may be necessary in order to comply with any of the provisions in these presents contained.
- (b) No member shall be entitled to visit or inspect any works of the Company without the permission of the Directors or to required discovery of or any information respecting any detail of the Company's trading, or any matter which may relate to the conduct of the business of the Company and which in the opinion of the Directors, it would be inexpedient in the interest of the Company to disclose.

INDEMNITY AND RESPONSIBILITY

Directors and others rights to indemnity

224. (a) Subject to the provisions of Section 201 of the Companies Act, 1956 every Director, Managing Director, Wholetime Director, Manager, Secretary and other officer or employee of the Company shall be indemnified by the Company against and it shall be the duty of the Directors, out of the funds of the Company to pay all costs, losses and expenses (including travelling expenses) which such Director, Manager, Secretary and Officer or employee may incur or become liable to by reason of any contract entered into or act or deed done by him as such Director, Manager, Secretary, Officer or Servant or in any way in the discharge of his duties including expenses and the amount for which such indemnity is provided, shall immediately attach as a lien on the property of the Company and have priority between the members over all other claims.
- (b) Subject as aforesaid, every Director, Managing Director, Manager, Secretary or other officer and employee of the Company shall be indemnified against any liability incurred by him in defending any proceedings, whether civil or criminal in which judgement is given in his favour or in which he is acquitted or discharged or in connection with any application under Section 633 of the Companies Act, 1956 and Section 463 of Companies Act, 2013 in which relief is given to him by the Court and the amount for which such indemnity is provided shall immediately attach as a lien on the property of the Company.

GENERAL POWER

227. Wherever in the Companies Act, it has been provided that the Company shall have any right privilege or authority or that the Company could carry out any transaction only if the Company if so authorised by its Articles, then and in that case these regulations hereby authorise and empower the Company to have such rights privilege or authority and to carry such transactions as have been permitted by the Act.

SECTION IX: OTHER INFORMATION

MATERIAL CONTRACTS AND DOCUMENTS FOR INSPECTION

The following contracts (not being contracts entered into in the ordinary course of business carried on by our Company or entered into more than two (2) years before the date of this Prospectus) which are or may be deemed material have been entered or are to be entered into by our Company. These contracts, copies of which have been attached to the copy of the Prospectus, delivered to the Registrar of Companies, Gujarat, Dadra and Nagar Haveli, for registration and also the documents for inspection referred to hereunder, may be inspected at the Registered Office of the Company at 3/2, Labdhi Industrial Estate, Acid Mill Compound, Ranmukteshwar Road, Pratapnagar, Vadodara – 390004, Gujarat, India, from 10.00 a.m. to 5.00 p.m. on Working Days from the date of the Prospectus until the Issue Closing Date.

Material Contracts

1. Memorandum of Understanding dated April 5, 2014 between our Company and Hem Securities Limited as LM to the Issue.
2. Memorandum of Understanding dated March 24, 2014 executed between our Company and the Registrar to the Issue.
3. Escrow Agreement dated June 4, 2014 among our Company, the LM, Escrow Collection Bank(s), Refund Bank(s) and the Registrar to the Issue.
4. Market Making Agreement dated April 5, 2014 between our Company, the LM and Market Maker.
5. Underwriting Agreement dated April 5, 2014 between our Company, the LM and Underwriter.
6. Tripartite Agreement among NSDL, the Company and the Registrar to the Issue dated March 27, 2014.
7. Tripartite Agreement among CDSL, the Company and the Registrar to the Issue dated March 18, 2014.

Material Documents

1. Certificate of Incorporation of Bansal Roofing Products Limited.
2. Our Company's Memorandum of Association and Articles of Association as amended.
3. Copy of the Board Resolution dated January 09, 2014 authorizing the Issue and other related matters.
4. Copy of the Shareholders' Resolutions dated January 20, 2014 authorizing the Issue and other related matters.
5. Copies of Audited Financial Statements of our Company for the years ended March 31, 2013, 2012, 2011, 2010 & 2009 and for 9 months period ended December 31, 2013.
6. Peer Review Auditors Report dated May 21, 2014 on Restated Financial Statements of our Company for the years ended March 31, 2013, 2012, 2011, 2010 & 2009 and for 9 months period ended December 31, 2013.
7. Copy of the Statement of Tax Benefits dated March 29, 2014 from the Statutory Auditor.
8. Consents of the LM, Legal Advisor to the Issue, Registrar to the Issue, Market Maker, Underwriter, Escrow Collection Bank(s) and Refund Bank(s), Statutory Auditor of the Company, Peer Review Auditor, Promoters of our Company, Directors of our Company, Accounts and Administration – Head Manager, Company Secretary and Compliance Officer, Bankers to our Company, as referred to, in their respective capacities.
9. Copy of Certificate from the Peer Review Auditors of our Company, M/s. V. J. Amin & Co., Chartered Accountants, dated May 29, 2014 regarding the Eligibility of the Issue.
10. Board Resolution dated May 22, 2014 for approval of Draft Prospectus.
11. In-principal approval dated June 6, 2014 from SME platform of BSE.
12. Due Diligence Certificate from Lead Manager dated May 22, 2014 filed with BSE along with filing of Draft Prospectus and dated June 16, 2014 to be submitted to SEBI along with filing of Prospectus.

DECLARATION

We, the persons mentioned herein below, as Directors or otherwise, certify that all relevant provisions of the Companies Act, 1956 as amended from time to time, Companies Act, 2013, to the extent notified, the guidelines issued by the Government of India and the regulations and guidelines issued by Securities and Exchange Board of India established under section 3 of the Securities and Exchange Board of India Act, 1992, as the case may be, have been complied with. No statement made in this Prospectus is contrary to the provisions of the Companies Act, 1956, Companies Act, 2013, to the extent notified and the Securities and Exchange Board of India Act, 1992, each as amended from time to time or the rules made there under or regulations and guidelines issued, as the case may be. We further certify that all the statements made in this Prospectus are true and correct.

SIGNED BY:

Sd/- Mr. Kaushalkumar S. Gupta <i>Chairman & Managing Director</i> DIN: 02140767	Sd/- Mrs. Sangeeta K. Gupta <i>Whole-time Director</i> DIN: 02140757
Sd/- Mr. Satishkumar S. Gupta <i>Whole-time Director</i> DIN: 02140734	Sd/- Mrs. Shilpa A. Jadeja <i>Non-Executive Independent Director</i> DIN: 06696913
Sd/- Mrs. Beena P. Bisht <i>Non-Executive Independent Director</i> DIN: 06696882	Sd/- Ms. Bhavitaben D. Gurjar <i>Non-Executive Independent Director</i> DIN: 06720448

SIGNED BY:

Sd/- Mr. Niladri S. Seal <i>Accounts & Administration – Head Manager</i>	Sd/- Ms. Harnetkaur S. Anand <i>Company Secretary and Compliance Officer</i>
---	---

Date: June 16, 2014

Place: Vadodara